

Jim Gleason's GUITAR ENCYCLOPEDIA

# CHORD FINGERING

Version 1.0 September, 2001

©2001 Jim Gleason

All Rights Reserved

[www.guitarpm.com](http://www.guitarpm.com)



# Contents

<b>INTRODUCTION</b> .....	7
Reading Fretboard Diagrams .....	8
Reading Tablature .....	12
Fretboard Note Names and Staff Locations .....	14
<b>1</b> <b>SCALES DEFINED</b> .....	23
What Is An Octave?.....	24
What Is A Scale? .....	24
What Is A Chord?.....	25
<b>2</b> <b>OCTAVE SHAPES</b> .....	27
The Full Fretboard Octave Pattern .....	28
Breaking It Down To What You Can Reach.....	31
<b>3</b> <b>INTERVALS</b> .....	37
What Is An Interval? .....	38
Fingering Whole Steps.....	38
Fingering Half Steps .....	39
Three Ways To Finger Whole And Half Steps.....	40
Numbering The Major Scale Tones .....	40
Recognizing The Half Steps In the Major Scale .....	41
Play A Major Scale On One String.....	42
Memorize Seven Major Scale Fingerings.....	42

<b>4</b>	<b>CONSTRUCTING MAJOR SCALES</b> .....	<b>45</b>
	Strict Vertical Position .....	46
	Beginning A Major Scale From the Little Finger On the Sixth String.....	47
	Major Scale Fingering Numbers.....	50
	Beginning A Major Scale From the Index Finger On the Sixth String.....	51
<b>5</b>	<b>CHORD CONSTRUCTION PREP</b> .....	<b>55</b>
	The Intervals Necessary To Construct A Major Chord.....	56
	Perfect Fifth Fingerings.....	56
	Major Third Fingerings .....	57
	Perfect Fourth Fingerings .....	68
<b>6</b>	<b>CHORD FORMULAS</b> .....	<b>59</b>
	What Are Chord Roots And Formulas?.....	60
	Chord Formulas By Family.....	60
<b>7</b>	<b>CONSTRUCTING MAJOR CHORDS</b> .....	<b>63</b>
	Common Major Chords By Octave Shape .....	64
	Reference Roots And Octaves.....	65
	Constructing Major Chords From The Root .....	66
<b>8</b>	<b>THE ROOT ID SYSTEM</b> .....	<b>69</b>
	What Is Strict Vertical Position? .....	70
	What Are Chord Roots, Tone Centers, Keys And Chord Progression? .....	70
	What Is A Root ID? .....	74
	Combining Root IDs .....	76
	Why Can't I Just Use The Octave Shapes Instead Of The Root ID? .....	77
<b>9</b>	<b>PRINCIPLES OF FINGERING</b> .....	<b>79</b>
	General Rules.....	80
	Changing Position .....	80
	Out-Of Position Notes.....	81

<b>10</b>	<b>CONSTRUCTING ARPEGGIOS</b> .....	<b>83</b>
	Overview.....	84
	Memorize Reference Arpeggios .....	84
	Choose A Fretboard Area .....	88
	Construct A Major Scale.....	90
	Access The Chord Formula .....	91
	Identify All Chord Tones .....	91
	Major Arpeggios In All Twelve Positions.....	94
	Deriving All Arpeggios From Major .....	97
	Summary Chord Fingerings.....	99
<b>11</b>	<b>“SPELLING” MAJOR SCALES</b> .....	<b>101</b>
	Spelling Major Scales Defined .....	102
	Preparing To Determine Chord Roots .....	102
	Key Signatures .....	103
	The Cycle Of Fifths .....	106
	Q & A On Key Signatures .....	106
	Using Key Signatures To Spell Major Scales .....	107
<b>12</b>	<b>STRUCTURAL CHORD TYPES</b> .....	<b>109</b>
	Chords Are Usually Constructed In Thirds .....	110
	Chord Types.....	114
<b>13</b>	<b>IDENTIFYING THE CHORD ROOT</b> .....	<b>123</b>
	The Root Is Usually The Lowest Note In A Series Of Thirds .....	124
	Incomplete Chords .....	126
	Add-Tone And Suspended Chords.....	130
	Synonyms .....	132
<b>14</b>	<b>ESSENTIAL CHORD TONES</b> .....	<b>135</b>
	The Third, The Seventh and The Chord Name .....	136
	Implied Chord Tones .....	139
	Essential Chord Tone Charts .....	142

**15 CHORD INVERSION..... 151**  
What Is Inversion? ..... 152  
Root Position ..... 152  
First Inversion ..... 152  
Second Inversion ..... 152  
Third Inversion ..... 152

**16 Using The CD Rom ..... 155**  
Search By Chord Name..... 156  
Search By Chord Grid..... 157  
Navigation And Keyboard Shortcuts ..... 157  
Advanced Searches ..... 158

**17 FIGURE OUT ANY CHORD FINGERING ..... 161**  
The Goal Is To Not Need The CD Rom..... 162  
The Procedure..... 162

## **APPENDICES**

**A COMMON CHORD FINGERINGS ..... 163**  
**B EXERCISES ..... 169**  
**C SUMMARY CHORDS ..... 191**  
**D TWO NOTE CHORDS ..... 195**  
**E SCALE TONE CHORDS ..... 201**  
**F CHORDS BY TYPE ..... 209**

# Introduction

- **Reading Fretboard Diagrams**
- **Reading Tablature**
- **Fretboard Note Names & Staff Locations**

# Reading Fretboard Diagrams

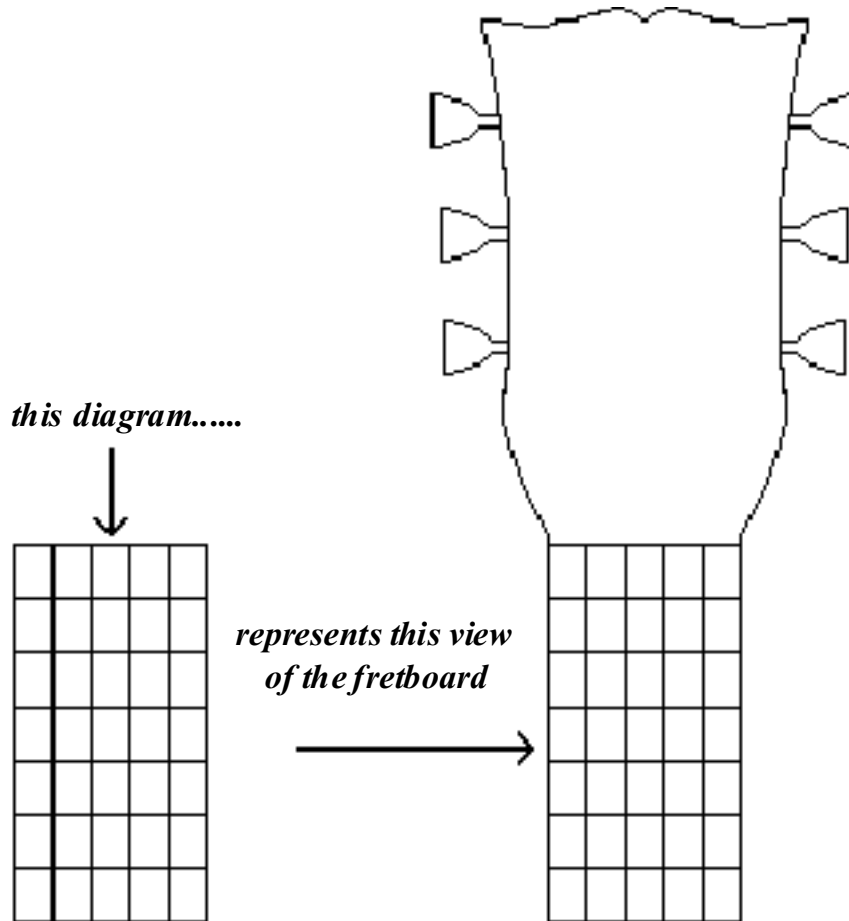

The vertical lines represent strings. The horizontal spaces are frets (numbered alongside the diagrams). The actual metal fret is indicated by the horizontal line at the bottom of each space on the diagram.

**vertical lines are strings**  
(numbered above diagram)

6 5 4 3 2 1

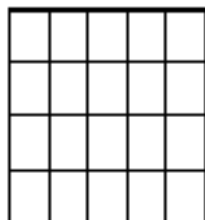

1 **horizontal spaces are frets**  
(numbered alongside the diagram)

2

3

4



## Dots

Dots in these diagrams indicate fingered notes. Chord tones are fingered simultaneously. Scale or arpeggio tones (chords played one note at a time) are fingered individually.

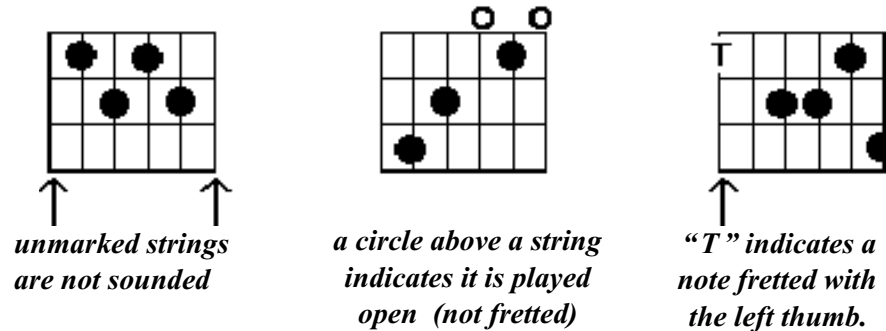

## The Barré

The barré is a group of notes all on the same fret of two or more strings. It is fingered with a straight portion of one finger. It uses the classical wrist position, with the base of the fingers parallel to the fretboard. Fret the barré with the harder edge of your finger when you can. Avoid the creases opposite your knuckles, since they can mute notes.

In the “F” chord shown below with finger numbers, it is left up to the reader to interpret that the first finger is placed across all six strings (as shown by the diagram to its right).

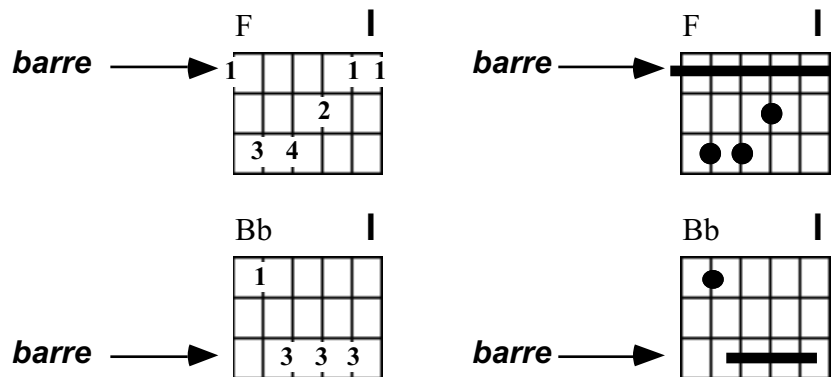

## Guitarists Playing Left-Handed Guitars

Guitarists playing left-handed guitars should interpret references to the right hand as left and vice-versa. For the left-handed guitarist, all diagrams should be imagined in “mirror image”.

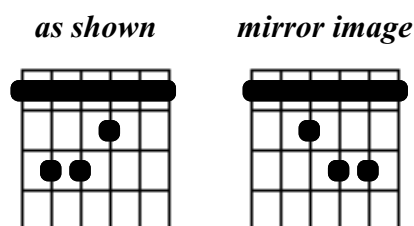

## ROMAN NUMERALS AND CHORD NAMES

### Roman Numerals

A roman numeral above the top right of the diagram indicates the number of the top fret on the diagram.

A plain letter name, such as “D” indicates a major chord. A small “m” after a letter name indicates a minor chord. “D” means “D major”, while “Dm” means “D minor”. A few more common chord symbol abbreviations are shown a couple of pages later.

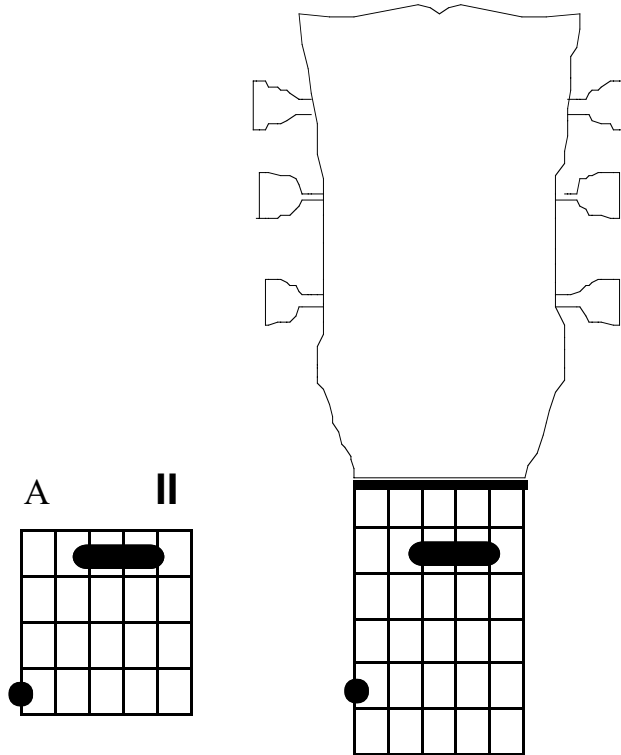

### Roots and Tone Centers

A chord root is the note after which a chord is named (“D” is the root of a D major chord). A tone center is the note after which a scale is named (“C” is the tone center of a C Lydian scale).

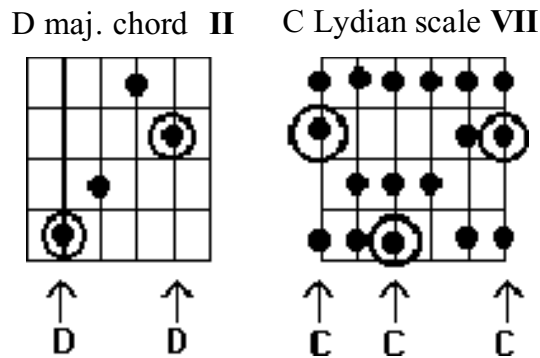

### Movable Diagrams

Movable diagrams have no roman numeral on their upper right and therefore have no specified top fret number. They may be placed anywhere on the fretboard according to their chord root(s) or tone center(s). If notes on a diagram are indicated by dots, a circled or enlarged dot indicates the chord root or tone center.

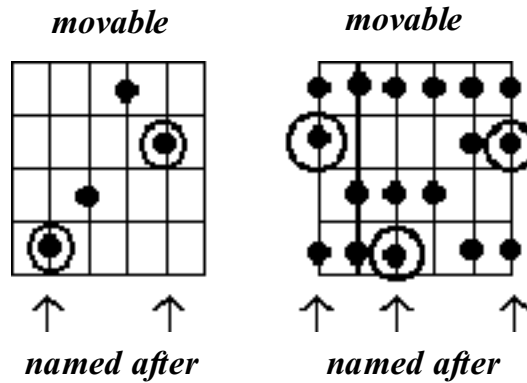

The numbers 1, 2, 3 and 4 within diagrams indicate left hand fingers. The finger number on the chord root or tone center may be circled.

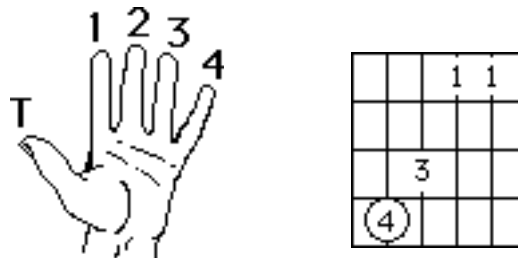

When numbers higher than 4 are used in a diagram, all of the numbers indicate scale, chord or arpeggio tones.

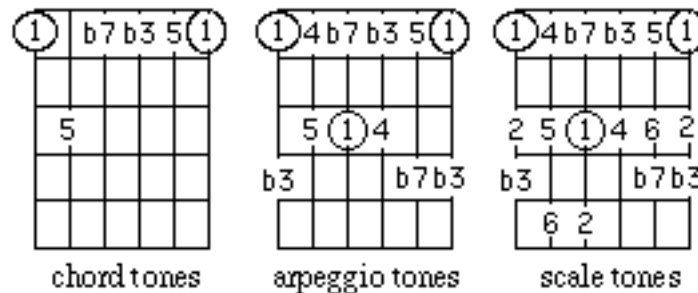

### Procedure Of Reading Chord Diagrams

You read the previous pages and are anxious to play songs. How complicated can it be? True, chord diagrams are a simple graphic representation of fingers on the fretboard, but be careful not to make an error in reading them. It is quite common that someone new to reading chord diagrams “thinks” they have read a diagram correctly, and doesn’t find out until much later (if at all) that they have made an error.

## TAKE YOUR TIME AND READ CHORD DIAGRAMS RIGHT THE FIRST TIME.

1. Read the header (Gm III) with the chord name and roman numeral for position.
2. Read across the frets one string at a time from the sixth (largest) string to the first string. Allow three to five seconds for each string. The strings are numbered from sixth to first as you scan across the diagram from left to right.
3. A few things to be careful to recognize:
  - whether notes are on the same fret or different frets
  - when there is an “empty” fret.
  - when notes are on adjacent strings
  - when a string is skipped.

### CHORD ABBREVIATIONS & SYMBOLS

7	= seventh chord (dominant)	9	= ninth chord
7#5	= seventh sharp five chord (dominant)	9#5	= ninth sharp five chord (dominant)
7b5	= flat five chord (dominant)	9b5	= ninth flat five chord (dominant)
7#9	= seventh sharp nine chord (dominant)	°7	= diminished seventh chord
C	= C major chord	Cm	= C minor chord
6	= sixth chord (major sixth chord)	m6	= minor sixth chord
6/9	= sixth add nine chord	m6/9	= minor sixth add nine chord
Δ7	= major seventh chord	m7	= minor seventh chord
Δ9	= major ninth chord	m9	= minor ninth chord
/9	= major add nine chord	m/9	= minor add nine chord
m7b5	= minor seventh flat five chord	sus. 4	= suspended fourth chord
m(ma7)	= minor, major seventh	sus. 2	= suspended second chord
n3	= no third		
n5	= no fifth		

# Reading Tablature

This system of notation is a graph of the guitar strings from the perspective of looking down on the guitar as you're playing it. The tablature indicates where each note is fretted. Numbers on the strings indicate frets and are written from left to right in the sequence they are to be played. In this book, tablature is written below all music notation.

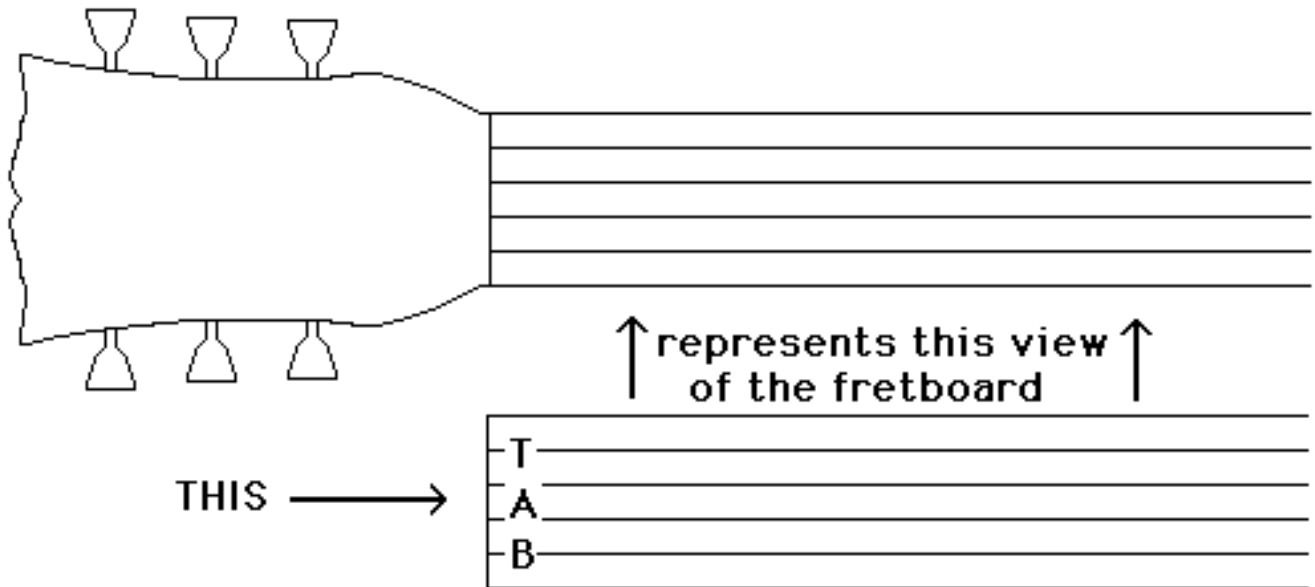

## Symbols For Fingers

The symbols that indicate the fingers of each hand are shown below. They are typically placed below the standard music notation, between the music notation and the tablature.

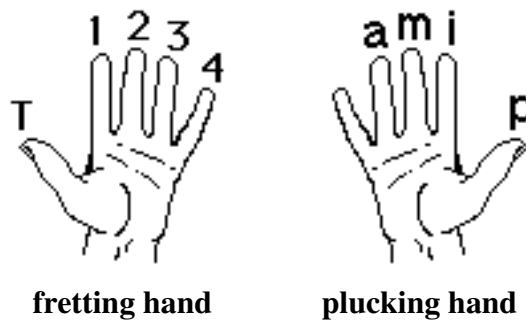

### Symbols Above The Tablature

Symbols above each tablature number indicate the suggested fretting finger. Right hand symbols are shown above or below notes in the standard music notation. The right hand finger symbols are “p” (pulgar = thumb in Spanish), “i” (indice = index finger in Spanish), “m” (medio = middle finger in Spanish) and “a” (anular = ring finger in Spanish). In reading the tablature, remember that the top string on the tablature is the smallest, first string.

this row of numbers represents the fretting fingers

these are the symbols used to represent the fretting fingers

fret numbers

this bottom line represents the sixth string (largest)

this top line represents the first string (smallest)

this row of arrows shows the downward and upward picking strokes

### Supplementary Grid Diagrams

The grid diagrams shown above the music notation in the diagram below are aids in reading the tablature. Instruction on reading these grid diagrams is on the following pages. The grid diagrams are used in this course where the fretting hand mainly retains a particular chord fingering. You still should read the guitar part in the tablature, since it shows the exact sequence of notes.

plucking fingers

plucking: a p i p m p i a p p i p m p i

this row of arrows shows plucking fingers

# Fretboard Note Names & Staff Locations

string: 6 5 4 3 2 1

OPEN STRINGS

1st fret

2nd fret

3rd fret

4th fret

5th fret

6th fret

7th fret

8th fret

9th fret

10th fret

11th fret

12th fret

13th fret

14th fret

15th fret

16th fret 8va higher than written

17th fret 8va higher than written

18th fret 8va higher than written

19th fret 8va higher than written

20th fret 8va higher than written

21st fret 8va higher than written

22nd fret 8va higher than written

6	5	4	3	2	1
E	A	D	G	B	E
F	A#	D#	G#	C	F
F#	Bb	Eb	Ab	C#	F#
G	B	E	A	Db	Gb
G#	C#	F#	A#	D#	G#
Ab	Db	Gb	B	Eb	Ab
A	D	G	C	E	A
A#	D#	G#	C#	F	A#
Bb	Eb	Ab	Db	F#	Bb
B	E	A	D	Gb	B
C	F	A#	D#	G	C
C#	F#	Bb	Eb	G#	C#
Db	Gb	B	E	Ab	Db
D	G	C	F	A	D
D#	G#	C#	F#	A#	D#
Eb	Ab	Db	Gb	Bb	Eb
E	A	D	G	B	E
F	A#	D#	G#	C	F
F#	Bb	Eb	Ab	C#	F#
G	B	E	A	Db	Gb
G#	C#	F#	A#	D#	G#
Ab	Db	Gb	B	Eb	Ab
A	D	G	C	E	A

\* *Guitar sounds one octave lower than written.*

## FIRST POSITION NATURAL NOTES

Play the notes below and speak the letter names. Notice that “E” to “F” and “B” to “C” are one fret apart. The other alphabetical pairs of notes (AB, CD, DE, FG and GA) are two frets apart. Remember, the musical alphabet starts over after “G”.

## FIRST POSITION NATURAL NOTES

### WITH DUPLICATIONS AT THE FIFTH (AND FOURTH) FRETS

The example below shows the locations of fretted notes which are the same pitch and note names as the next smaller string open. Except for the third string, this occurs at the fifth fret. The third string, fourth fret, is the same pitch as the second string, open.



## NOTE NAMES ON THE STAFF

### The Staff

The staff is a group of five horizontal lines on which music is written. The plural is usually “staves”, but may be “stuffs”. Bar lines (above) are vertical lines written across the staff to divide it into groups of beats. Each group of beats is called a bar. Time signatures indicate the number of beats in the bars that follow it, as well as the relative beat value of each note.

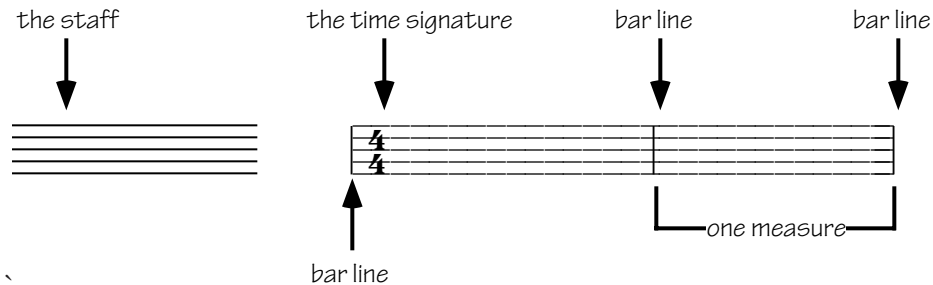

Ledger lines are short lines placed above or below the staff to add to its range.

### Note Parts

The parts of notes are the head, stem, flag, beam and dot. The head of a note is an oval. It is centered vertically on or between the lines of the staff. The whole note's only part is its head.

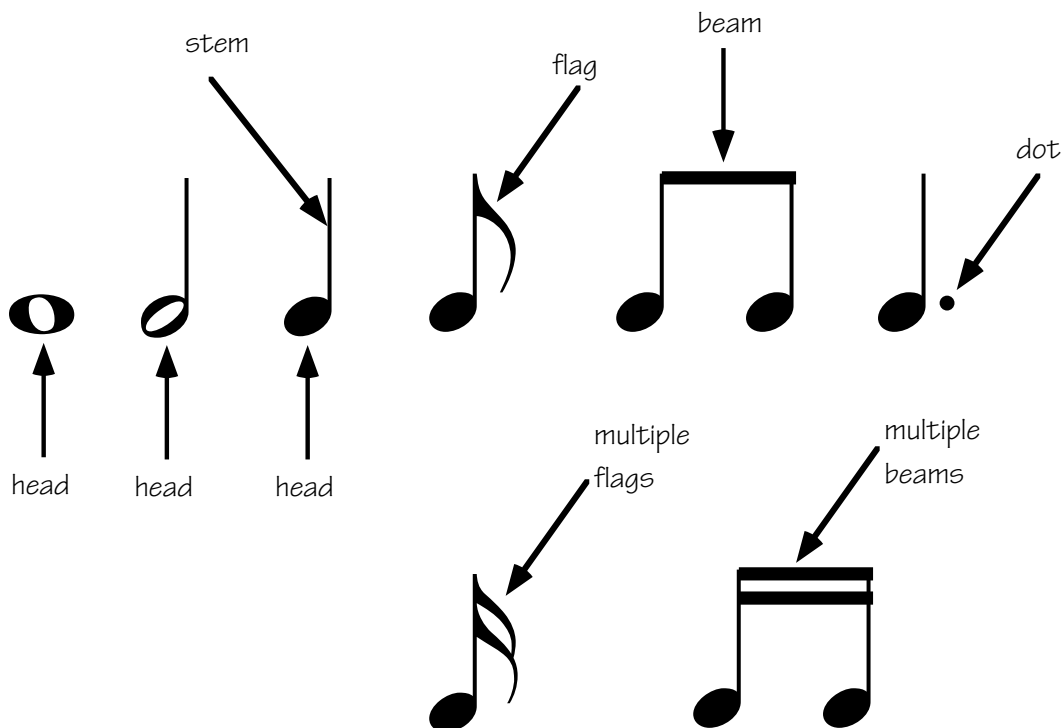

The stem of a note is a vertical line connected to the head. It connects to the left if it goes down from the head and to the right if it goes up. Stems on note heads above the middle of the staff are usually written down. Stems on heads below the middle of the staff are usually written up. Stems on the center line of the staff can be written up or down.



A flag or a beam halves the time value of a note. Each additional flag or beam cuts the value in half again. A dot multiplies the value of a note by one and a half. Two dots multiply the value of a note by one and three quarters.

### Up And Down Stems

When two voices (two instruments or voice parts) are written on the same staff, the upper part is usually written with all stems up and the lower part with all stems down:



### Treble And Bass Clefs

A clef is a sign placed on the staff at the beginning of a piece of music to indicate the placement of the letters. The letters used in music include “A, B, C, D, E, F, and G.”

The treble clef or “G” clef assigns the letter “G” to the second line from the bottom of the staff. Guitar music is written on the treble clef. Notes on the treble clef are completely above those on the bass clef in pitch.



The bass clef or “F” clef assigns the letter “F” to the second line from the top of the staff. Notes on the bass clef are completely below those on the treble clef in pitch.



## Middle C

Middle C is the C nearest the middle of the piano keyboard. It is the “dividing line” between the treble and bass clefs. It is on the first ledger line below a staff using the treble clef and the first ledger line above a staff using the bass clef.

The treble and bass clefs were originally part of the great staff, which had eleven lines. The top five lines were extracted to make the treble clef, and the bottom five lines were extracted to make the bass clef. The center line of the great staff was middle C.

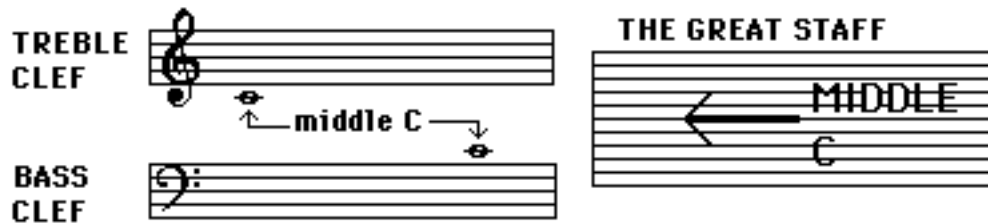

The notes on the staves are in alphabetical order:

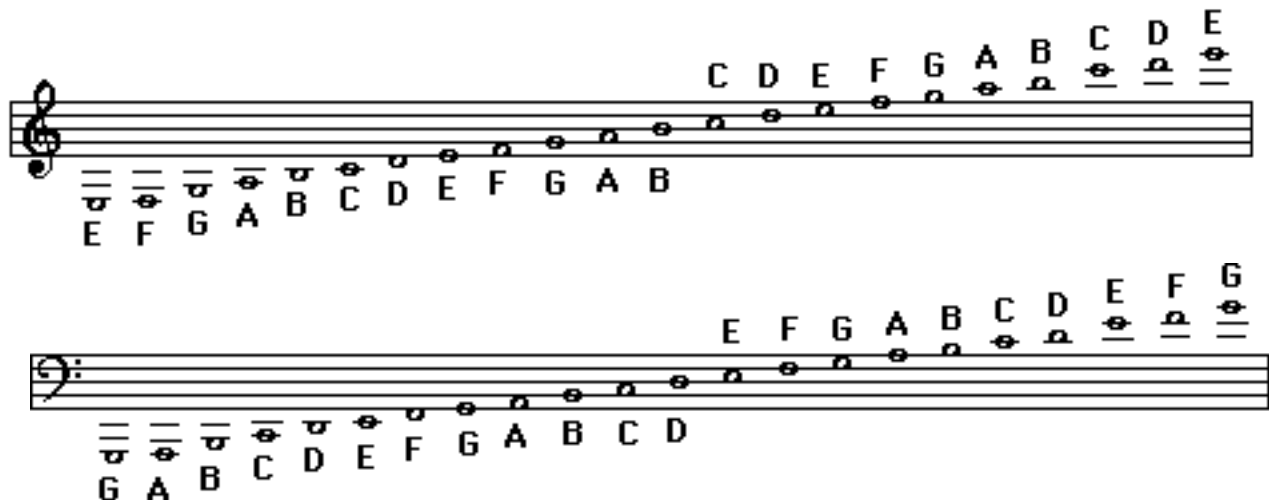

## Guitar Transposes One Octave

Guitar is usually written on the treble clef, transposed down one octave.

### NOTES WRITTEN FOR GUITAR HERE



### ACTUALLY SOUND HERE



## Memorizing Note Names

The letter names on the treble clef are easy to memorize with the use of a few associations. From bottom to top, the notes on the lines of the staff are the first letters of the words in this sentence: Every Good Boy Does Fine. From bottom to top, the notes on the spaces of the staff spell the word "FACE."



The notes on the lines (including ledger lines) are in an alternate alphabetical pattern: A, C, E, G, B, D, F, A, C, etc. Likewise, the notes on the spaces are in the same alternate alphabetical pattern: A, C, E, G, B, D, F, A, C, etc. Memorize the alternate alphabetical cycle shown at the right below:



## Note Names In Reverse Order (GFEDCBA or "gee-fed-cee-bah")

Most of us were not taught to think the alphabet backward, as well as forward. In music, whenever notes descend (go down) a seven tone scale such as the major scale, you will need to think the letters backward. As a memory device, think of the reverse series of letters as a middle eastern-sounding word, pronounced: "gee-fed-cee-bah". Of course, the notes continue down the scale after "A", forming the cycle "GFEDCBAGFED, etc."

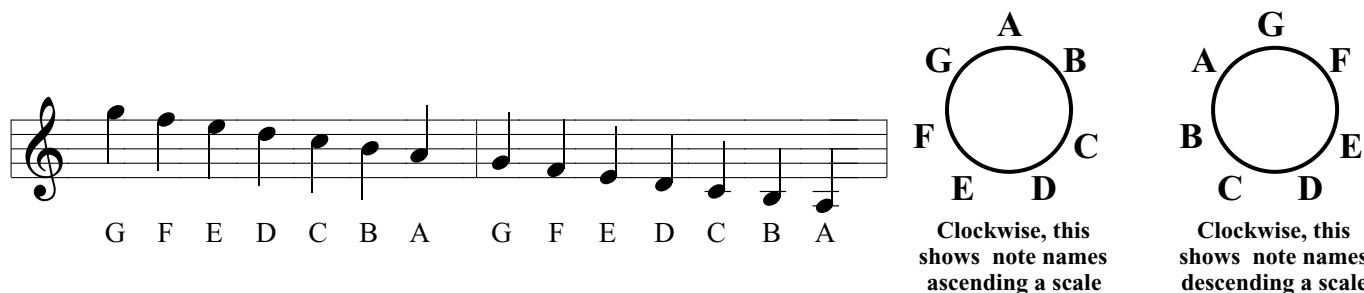

Clockwise, this shows note names ascending a scale

Clockwise, this shows note names descending a scale

## MEMORIZING FIRST POSITION NOTE NAMES

### Memorizing First Position Note Names On The Staff

- The notes go up from line to space in alphabetical order.
- “E”, “F” and “G” each occur in three places in the range of notes shown below.
- “A”, “B”, “C” and “D” each occur in two places in the range of notes shown below.
- The lowest of each of the natural notes in first position is below the staff.
- The middle of each of the sets three notes with the same name (E, F and G) is near the bottom of the staff.

the center line is “B” for “bulls-eye”

*lowest*                      *middle*                      *highest*

- Spaces (notes between lines) are FACE, from bottom to top. Going up on lines beginning with the third ledger line below the staff is also FACE.
- Lines from bottom to top are represented by the first letter of each word in the sentence: Every Good Boy Does Fine. Going up on spaces beginning with the note below the third ledger line below the staff is also EGBDF.
- “B” is on the center line of the staff. Think of it as the “bulls-eye” (see the arrow at the right above).
- FACE and EGBDF overlap in the every-other-letter cycle FACEGBD shown at the right below.

F A C E    E G B D F    F A C E    E G B D F

The every-other note letter cycle includes “FACE” and EGBDF (Every Good Boy Does Fine).

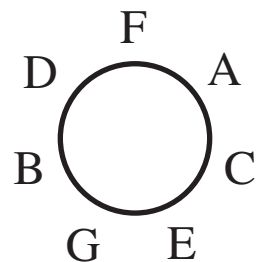

### Memorizing First Position Note Names On The Guitar

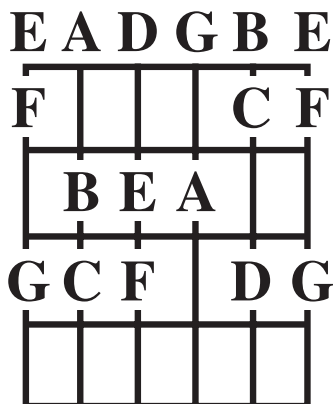

- The open strings, from sixth to first string are Eat A Darn Good Breakfast Early (E A D G B E).
- E to F is one fret. B to C is one fret.
- AB, CD, DE, FG and GA are each two frets apart.
- There are three each of the notes E, F and G.
- The note name at any fret on the sixth string is the same at that fret on the first string.
- Octaves “skip” one or two strings, depending on their angle. Octaves are notes which have the same name, but are eight letter names apart (counting the starting and ending notes). See the diagrams at the left below.
- Octaves of A, B, D, E and G each include an open string.
- The fingering pattern on strings 1, 2 and 6 is open, 1, 3.
- The fingering pattern on strings 5 and 4 is open, 2, 3.
- The fingering pattern on string 3 is open, 2.
- Memorize the locations of the notes after which each chord is named below

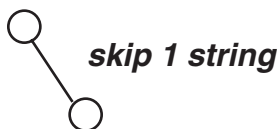

The top fret on all of the diagrams below is the first fret. The tiny circles above the chord diagrams indicate open strings (not fretted). Notes enclosed in the large circles below have letter names after which the chord is named. In each diagram, the notes enclosed in the large circles are octaves (eight letter names apart). Letter names for notes above the diagrams indicate open strings.

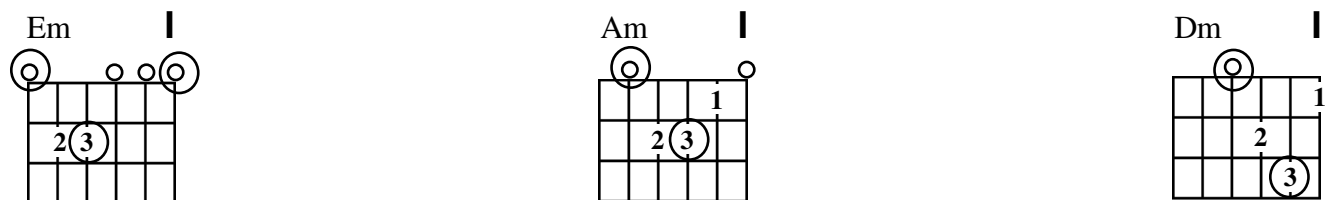
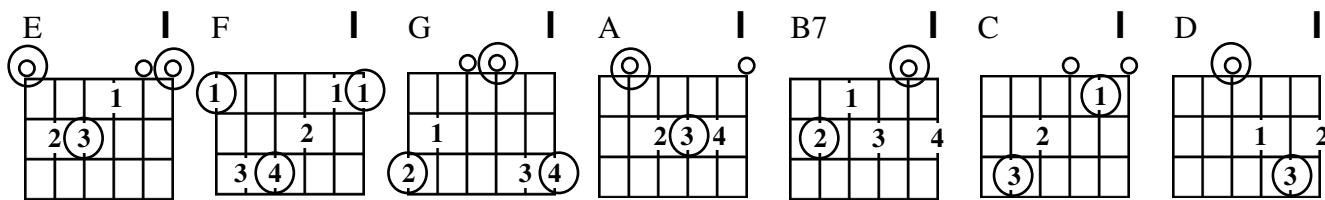
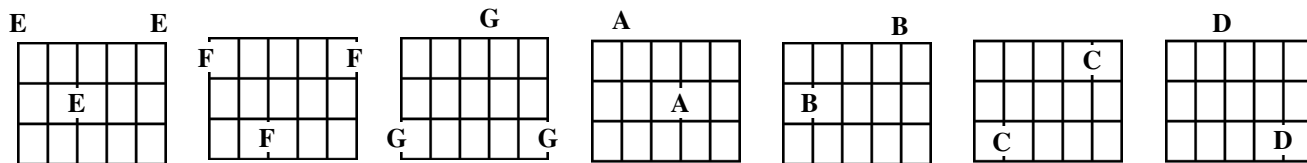

# Scales and Chords Defined

- **What Is An Octave?**
- **What Is A Scale?**
- **What Is A Chord?**
- **Can A Chord Be A Scale And Vice-versa?**

# What Is An Octave?

When notes are arranged in ascending or descending alphabetical order, every eighth note repeats. This range between the first and eighth notes in this alphabetical order is called an octave.

## C major scale, range one octave

C D E F G A B C one octave

T 4/4 0 2 0 1 3

A 4/4 3 0 2 3 0 2 0 1

B 4/4 3 0 2 3 0 2 0 1

## G major scale, range one octave

G A B C D E F# G one octave

T 4/4 0 2 0 1 3 0 2 3 3

A 4/4 0 2 0 1 3 0 2 3 0

B 4/4 0 2 0 1 3 0 2 3 0

# What Is A Scale?

A scale is a collection of between five and twelve notes (inclusive) that spans an octave. When playing the notes of a scale in ascending or descending order, they repeat at the octave.

## C major Scale, seven notes per octave

C major scale VIII

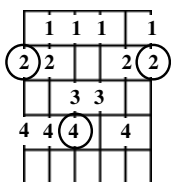

letter names: C D E F G A B C D E F G A B C

T 4/4 8 10 7 8 10 7 9 10 7 9 6 8 10 7 8

A 4/4 8 10 7 8 10 7 9 10 7 9 6 8 10 7 8

B 4/4 8 10 7 8 10 7 9 10 7 9 6 8 10 7 8



### C minor 7/11 pentatonic scale, five notes per octave

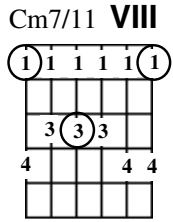

letter names: C Eb F G Bb C Eb F G Bb C

### C whole tone scale, six notes per octave

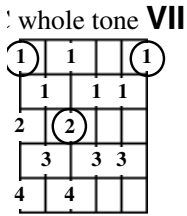

letter names: C D E F# G# Bb C D E F# G# Bb C

### C chromatic scale, twelve notes per octave

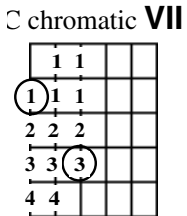

letter names: C C# D D# E F F# G G# A A# B C

## What Is A Chord?

A chord is a collection of two or more notes which, when sounded at once, create a sound that can be used in a piece of music. Any chord tone may be doubled. A chord with three *different* notes may have four notes, where one note occurs twice. Two note chords are typically referred to as intervals.

### Two Note Chords

perfect fifth      minor sixth      minor sixth      major sixth

### Three Note Chords

<p><b>C</b>     <b>III</b></p>	<p><b>F</b>     <b>V</b></p>	<p><b>Am</b>     <b>V</b></p>	<p><b>G</b>     <b>III</b></p>	<p><b>A5</b>     <b>II</b></p>
--------------------------------	------------------------------	-------------------------------	--------------------------------	--------------------------------

### Three Note Chords With Note Doubling

<p><b>C</b>     <b>I</b></p>	<p><b>F</b>     <b>I</b></p>	<p><b>Am</b>     <b>I</b></p>	<p><b>G</b>     <b>I</b></p>	<p><b>A5</b>     <b>I</b></p>
------------------------------	------------------------------	-------------------------------	------------------------------	-------------------------------

# Octave Shapes



- **The Full Fretboard Octave Pattern**
- **Breaking It Down To What You Can Reach**

# The Full Fretboard Octave Pattern

## THE "DIAMOND AND Z" PATTERN

Each note on the guitar fretboard repeats in the same pattern. The pattern could be described as a "diamond and Z". The diamond part of the pattern was drawn onto the fretboard diagram of "F" notes below. The "diamond and Z" was drawn onto the other diagrams. The heavy lines show one occurrence of the pattern. The diamond and Z could also be likened to a kite.

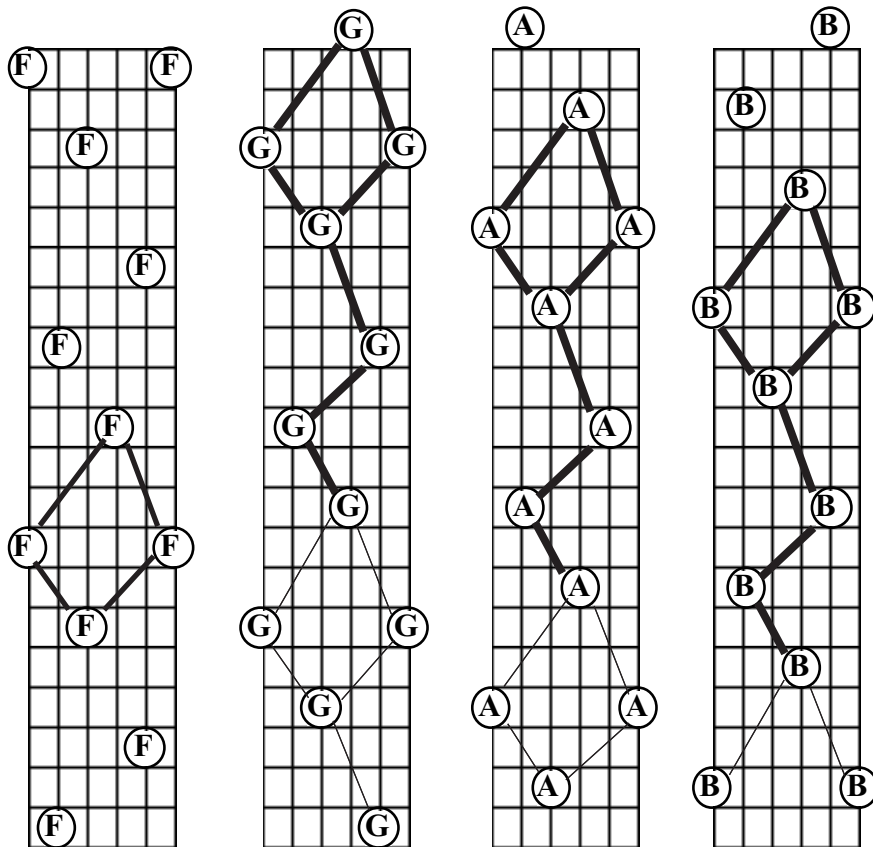

The diamond and Z pattern occurs on every note. It moves up the fretboard (toward the guitar's bridge) in the same alphabetical order as notes progress up each string.

## WHAT'S SO SIGNIFICANT ABOUT THE REPETITION OF EACH NOTE?

In working toward mastering the fretboard for whatever styles you're into, you need to learn to finger scales, chords, arpeggios and melodies in two ways:

- playing in one key all over the fretboard
- playing all keys in one area of the fretboard

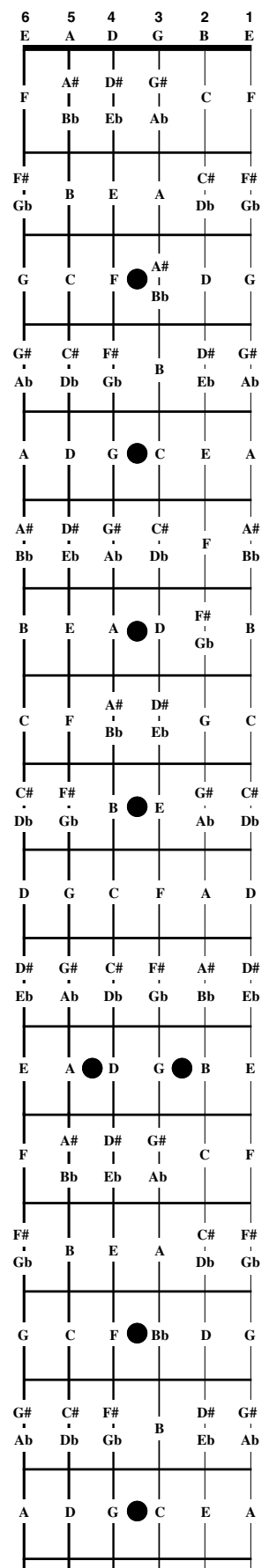

## Octaves

The repetitions of each note that are closest to each other are eight notes apart in a major scale, so they are called octaves. Each of the smaller diagrams below shows an eight note range of a major scale fingering, which spans an *octave*. You should play the major scale each of the small diagrams. Play the notes in numerical order, from “1” to “1”. The circled notes on each of the smaller diagrams are one octave apart.

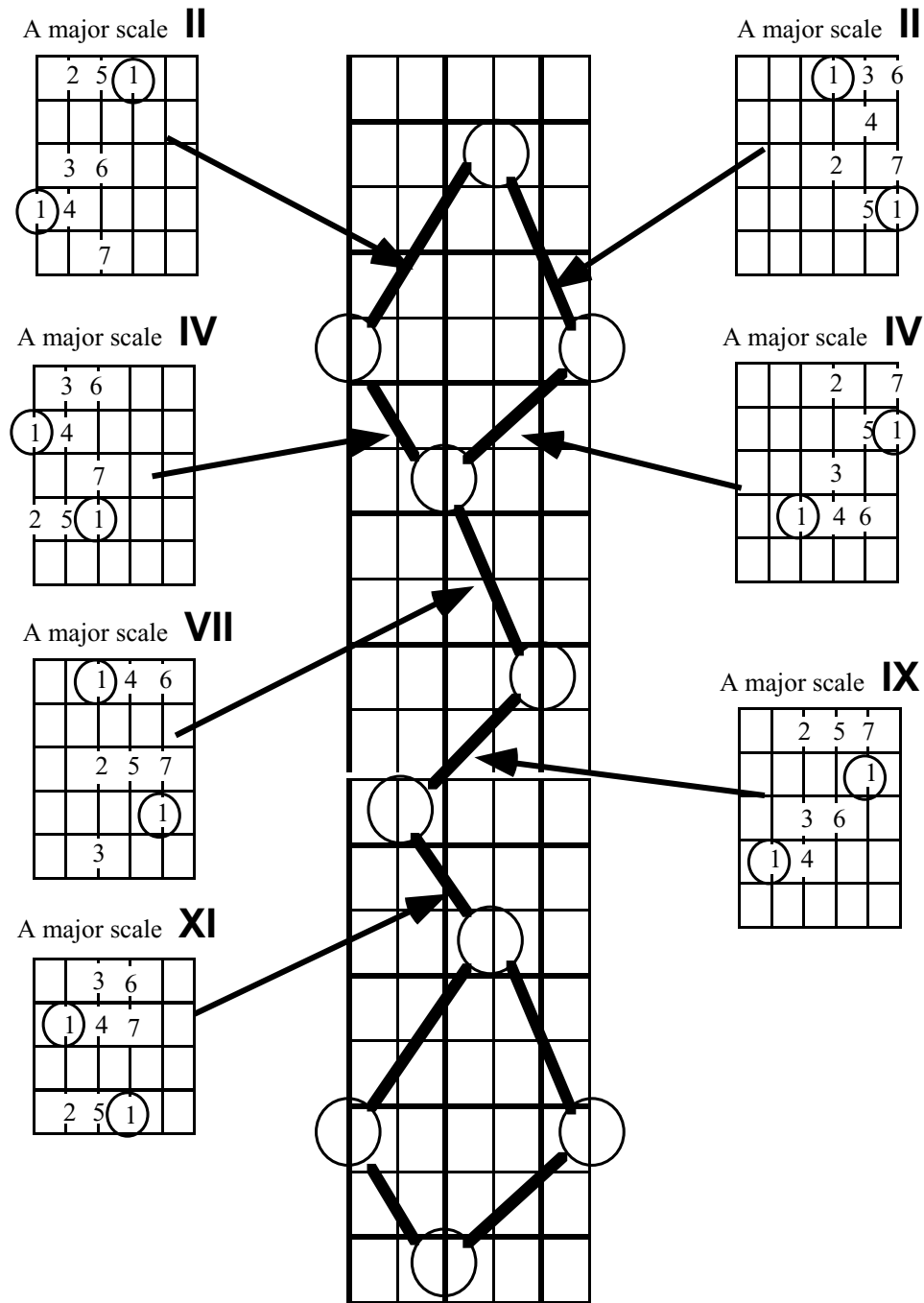

If you can play a major scale in any particular octave area, you can modify the major scale to make any other scale or chord, arpeggio or melodic phrase. All scales, chords, arpeggios and melodic phrases can be represented with the numbers and altered numbers of the major scale.

## Playing In One Key All Over The Fretboard

If you were to play all of the diagrams above on the fretboard relative to the large diagram, with the top fret on the large diagram assigned to a specific fret, you would be playing major scale fingerings in one key all over the fretboard. The key would be named after the note on which the "1's" occurred (which would all be the same note).

When playing a scale, arpeggio or melodic phrase at any particular location on the fretboard, you need to orient you current octave shape to the sequence of them, having memorized other fingerings categorized by their octave shape.

## Playing In All Keys In One Area Of The Fretboard

By playing all of the diagrams below with the top fret located at same place on the fretboard, each one will produce a different major scale, in all twelve keys (shown in fifth position below). Each vertical pair of diagrams shows scale tone numbers on the top diagram and fretting finger numbers on the bottom diagram.

### major scales in all keys, fifth position

<p><b>A major V</b> scale tones</p> <p>fingers</p>	<p><b>Bb major V</b> scale tones</p> <p>fingers</p>	<p><b>C major V</b> scale tones</p> <p>fingers</p>	<p><b>D major V</b> scale tones</p> <p>fingers</p>	<p><b>Eb major V</b> scale tones</p> <p>fingers</p>	<p><b>F major V</b> scale tones</p> <p>fingers</p>	<p><b>G major V</b> scale tones</p> <p>fingers</p>
--	---	--	--	---	--	--

the keys shown below are in fifth position, but involve the index finger reaching to the fourth fret

<p><b>Ab major IV</b> scale tones</p> <p>fingers</p>	<p><b>B major IV</b> scale tones</p> <p>fingers</p>	<p><b>Db major IV</b> scale tones</p> <p>fingers</p>	<p><b>E major IV</b> scale tones</p> <p>fingers</p>	<p><b>Gb major IV</b> scale tones</p> <p>fingers</p>
--	---	--	---	--

# Breaking It Down To What You Can Reach

We can comfortably reach a span of four or five frets, so the full fretboard pattern of octaves needs to be conceived in sections. Sections of three or four frets can be related to octaves.

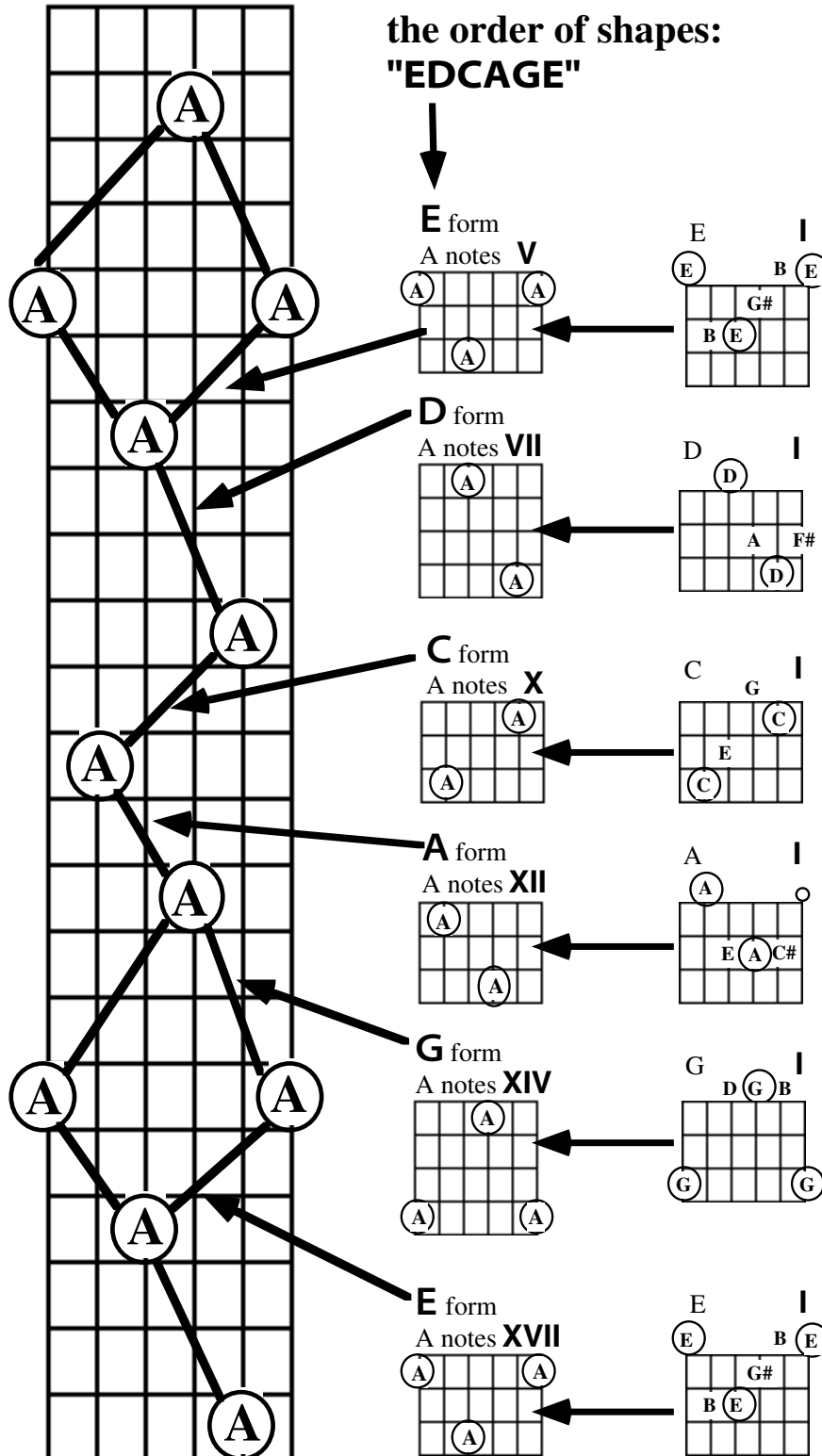

## FIVE CHORD ROOT SHAPES

The notes after which the open string chords E, D, C, A and G are named form the octave shapes shown at the left. In each of the five different chord diagrams, the circled notes are the notes after which the chord is named.

In the small "E form" diagram, "A" notes are shown in the shape that originated with the circled "E's" in an open position "E" chord. Likewise with the "D", "C", "A" and "G" forms, the "A" notes are in the *shape* of an open string chord after the form is named.

## EDCAGE

The circled notes are the chord roots. The roots of each chord represent a unique octave form. The octave forms occur in the order E, D, C, A, G, then repeat. To signify that the order repeats, I refer to the order as ED CAGE.

## THE SEVEN OCTAVE FINGERINGS

The diagrams below can be played in any position (at any fret). Numbers within the diagrams indicate fretting fingers.

### Primary Octave Fingerings

These are "two string, two fret" octaves.

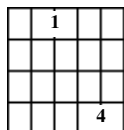
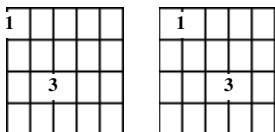

← These are "two string, two fret" octaves with compensation for tuning on the smallest two strings.

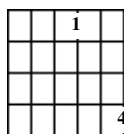

← Notes on the smallest two strings must relatively be moved up one fret (higher in pitch), when combined with the larger four strings..

### Secondary Octave Fingering

The only un-compensated "three string, three fret" octave (compensated versions are shown at the right).

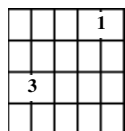
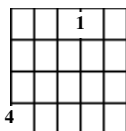

← These are "three string, three fret" octaves with compensation for tuning on the smallest two strings.

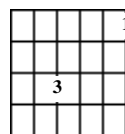

← Notes on the smallest two strings must relatively be moved up one fret (higher in pitch), when combined with the larger four strings.

## THE FIVE OCTAVE SHAPES

By combining two pairs of the seven octaves and using the other three octaves unchanged, five octave shapes are produced.

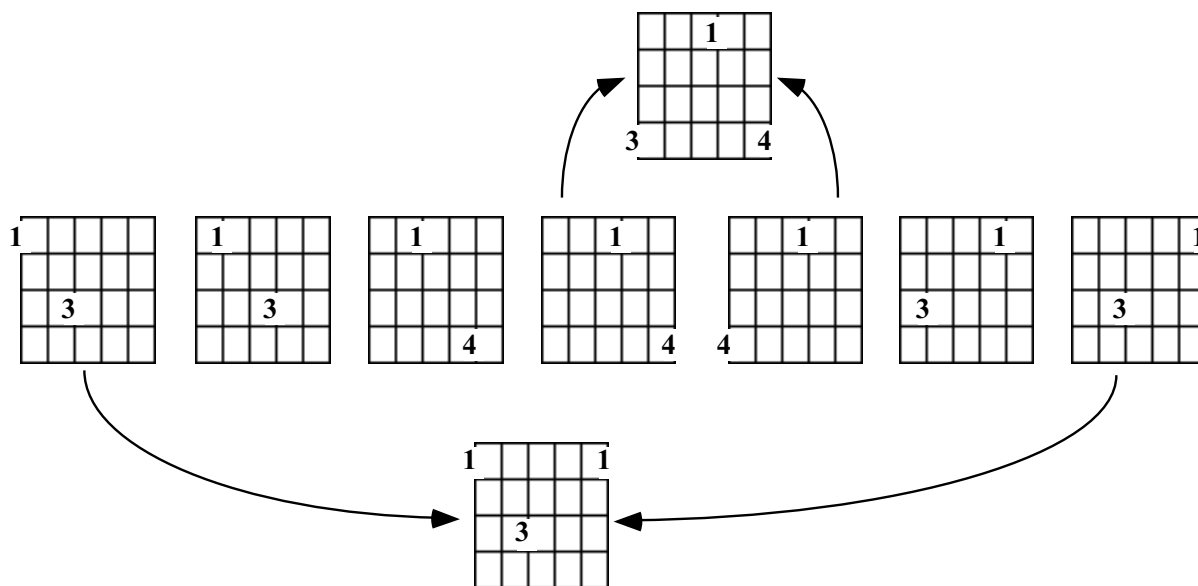



Here are the five octave shapes. Notice how each one occurs as the roots of an open string chord:

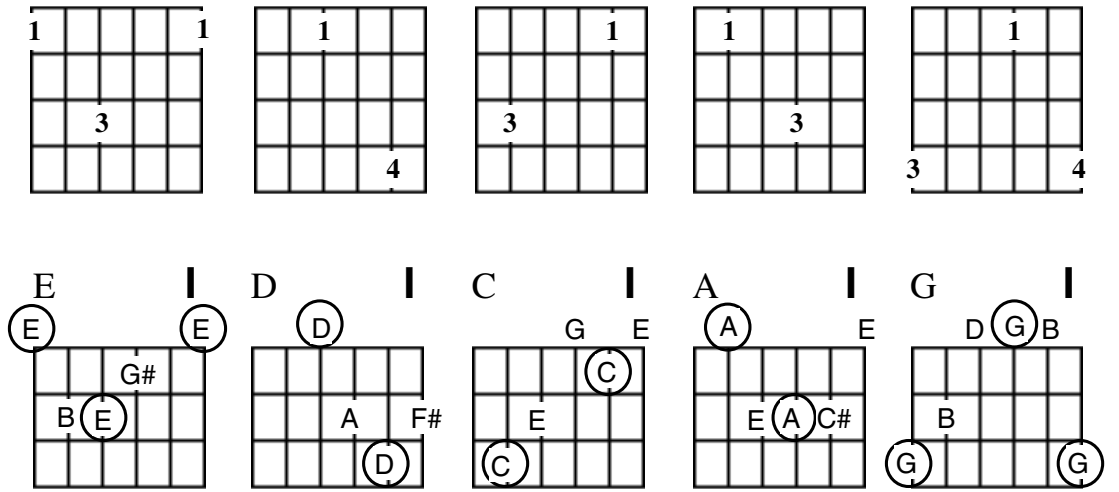

**Each Octave Shape Is Also An Octave Form**

The five octave shapes are named after either the strings on which they occur (641 shape) or the open string chord to which they are related (E form).

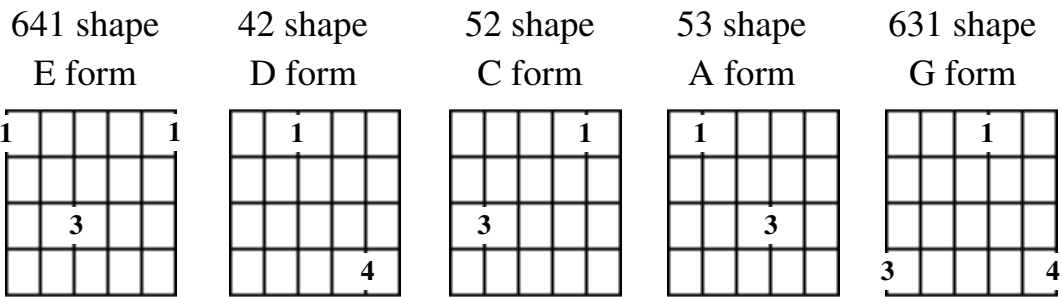

**The Octave Forms For Every Note**

Now that we have dissected the Diamond and Z pattern of octaves in the the individual octave forms, let’s put them back together and look at them for all keys.

Every note occurs in the same series of octave forms. Compare the diagrams below. In regard to pitch, “G” is a whole step (two frets) above “F”, “A” is a whole step above “G” and “B” is a whole step above “A”. Remember, “up in pitch” is toward the bridge, which would be physically down on these diagrams.

As you progress up alphabetically through the keys, the diamond and Z pattern “grows” onto the fretboard from the head of the guitar. Likewise, as you progress down alphabetically through the keys, it “dissappers” off of the fretboard. Be able to visualize the “diamond and Z” pattern up or down the fretboard.

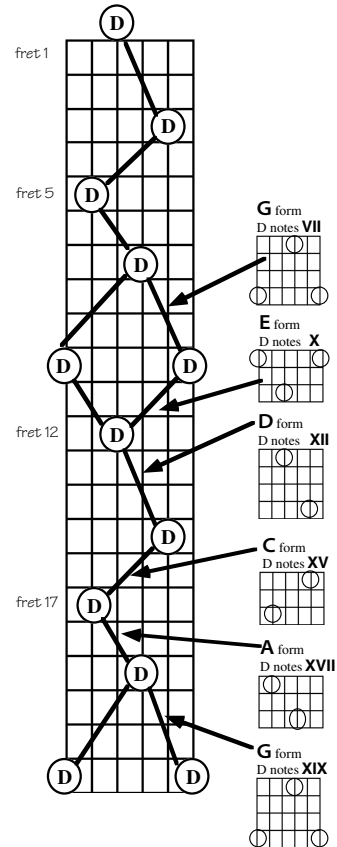
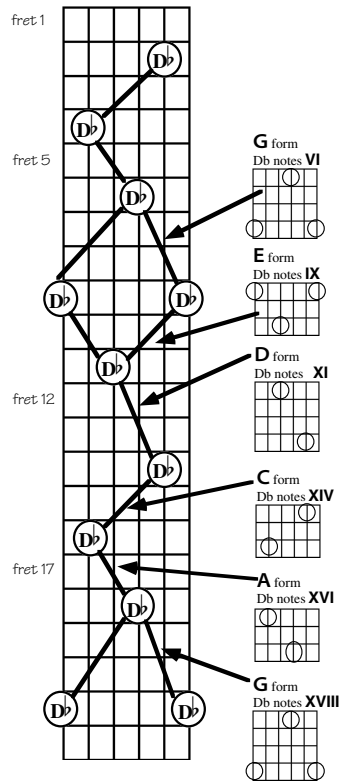
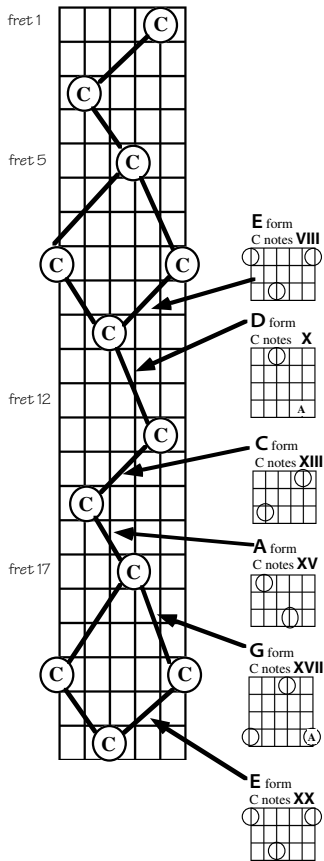
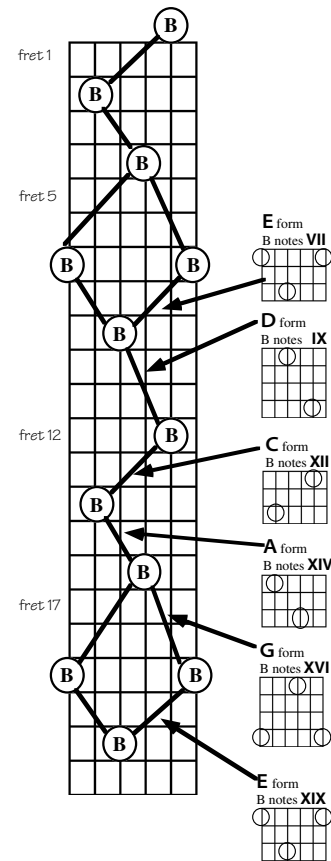
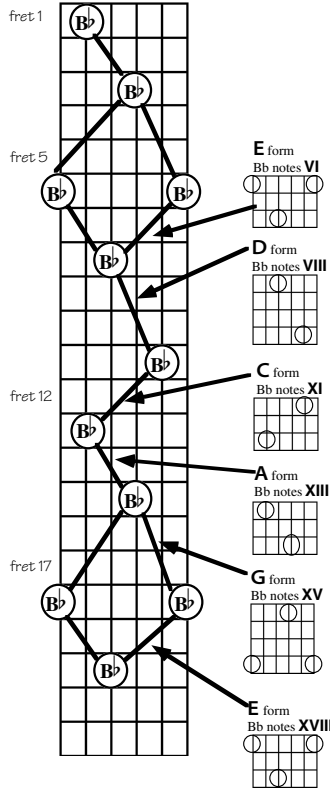
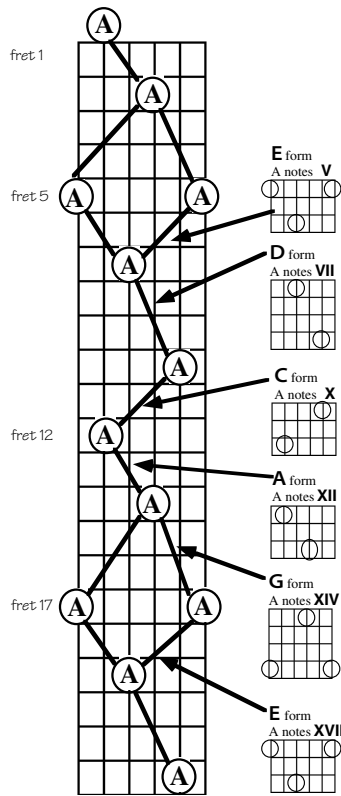

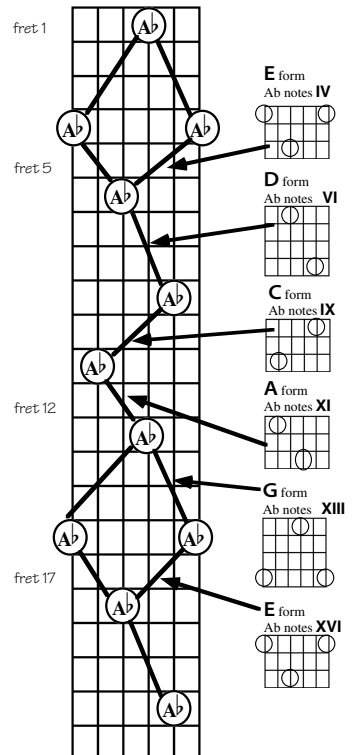
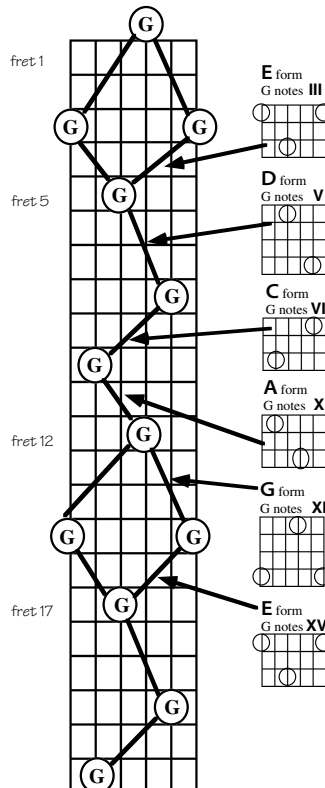
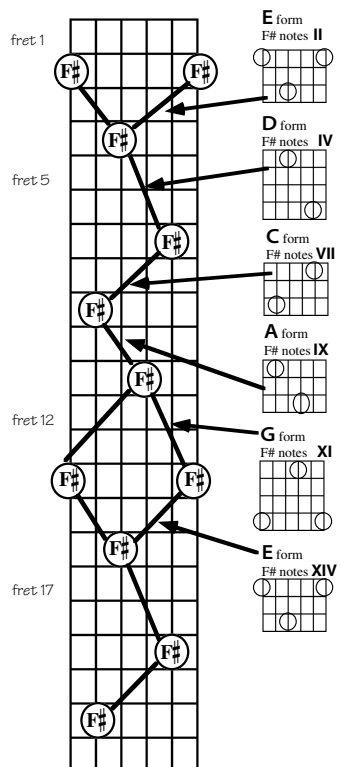
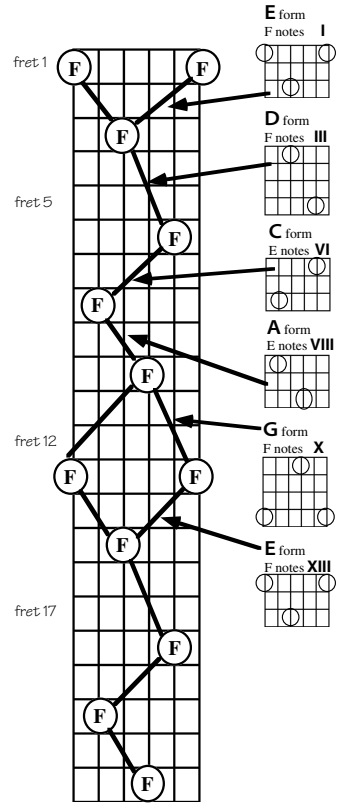
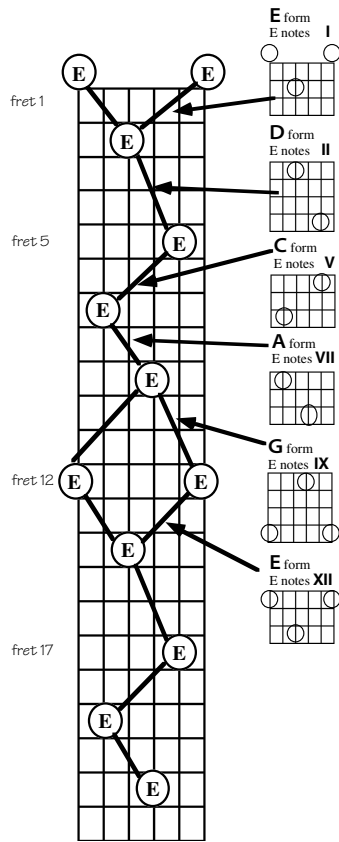
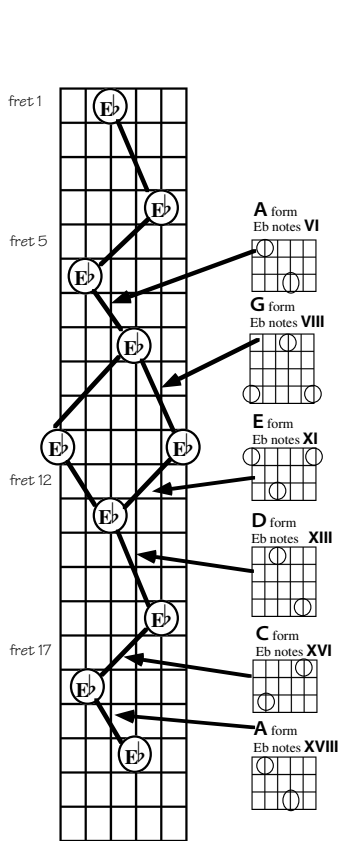



# Intervals

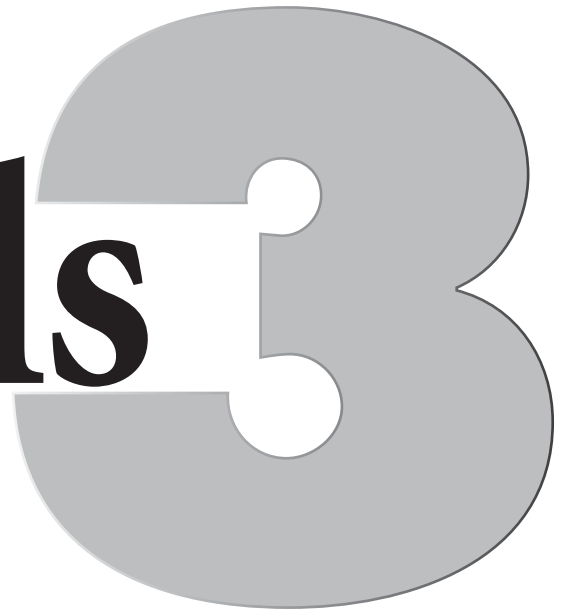

- **What Is An Interval?**
- **Fingering Whole Steps**
- **Fingering Half Steps**
- **Three Ways To Finger Whole And Half Steps**
- **Numbering The Major Scale Tones**
- **Recognizing The Half Steps In the Major Scale**
- **Play A Major Scale On One String**
- **Memorize Seven Major Scale Fingerings**

# What Is An Interval?

An interval is a measurement of the difference in pitch between two notes. Intervals are compared to distances between notes in the major scale. Before discussing the major scale, you'll need to know about the units used to measure the distances between its notes. The *whole step* is a standard unit of measurement that indicates (on the guitar) a distance of two frets. The *half step* indicates a distance of one fret.

## Fingering Whole Steps

### Whole Steps On A Single String

These can be fretted in any position (anywhere up and down each string). Notice that this fingering is the same for each pair of strings. Of course, the notes could be fretted with any combination of fingers.

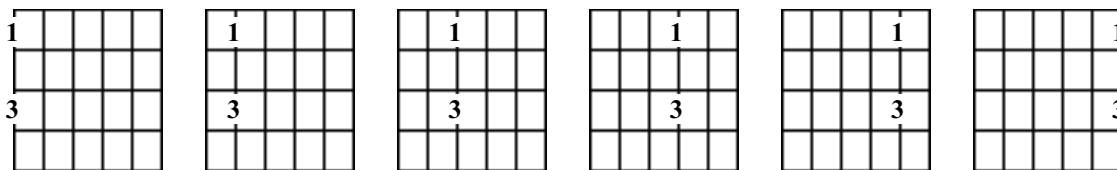

### Whole Steps With One Note On An Open String

This fingering is the same for each pair of strings. The fretted notes could be fretted with any finger.

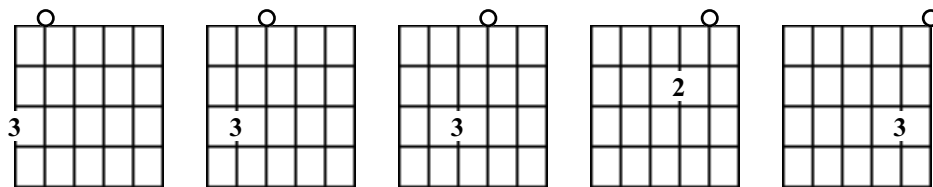

### Whole Steps Fretted On Each Of Two Adjacent Strings

This fingering is the same for each pair of strings *except* the third and second string, where it is fretted with one "empty" fret between the fingers, instead of two. The notes could be fretted with any practical combination of fingers.

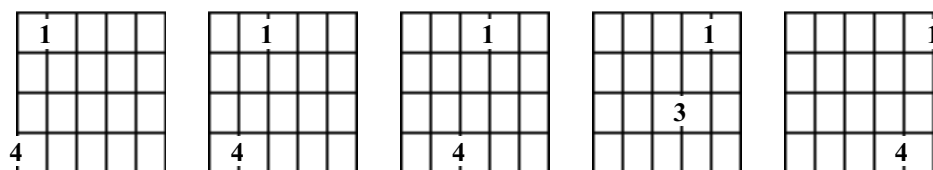

# Fingering Half Steps

## Half Steps On A Single String

These can be fretted in any position (anywhere up and down each string). Notice that this fingering is the same for each pair of strings. Of course, the notes could be fretted with any combination of fingers.

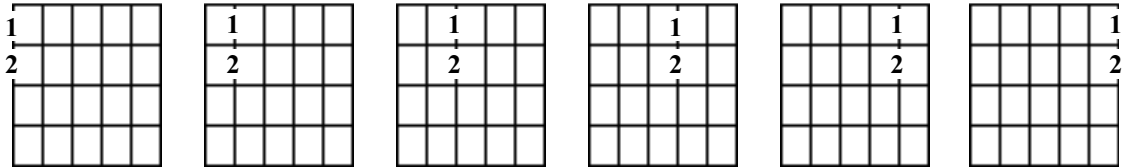

## Half Steps With One Note On An Open String

This fingering is the same for each pair of strings. The fretted notes could be fretted with any finger.

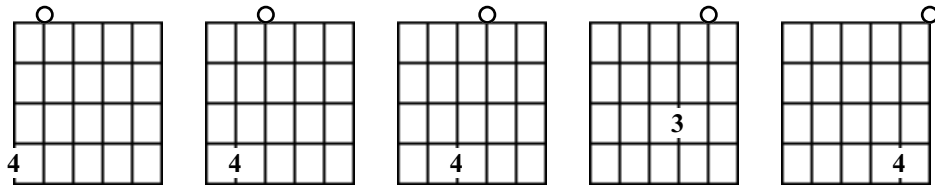

## Half Steps Fretted On Each Of Two Adjacent Strings

This fingering is the same for each pair of strings *except* the third and second string, where it is fretted with two “empty” frets between the fingers, instead of three. The notes could be fretted with any practical combination of fingers.

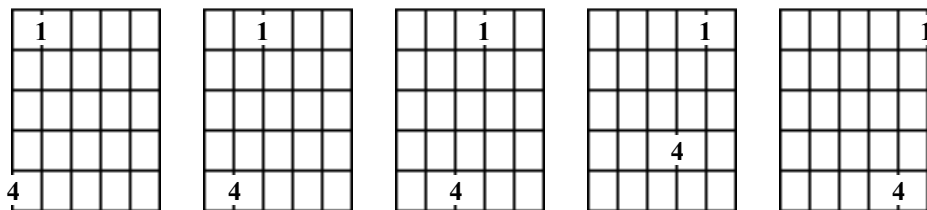

# Three Ways To Finger Half And Whole Steps

There are three ways to finger half steps and three ways to finger whole steps (not involving open strings):

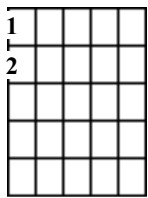

**a half step on one string**  
may be on any string,  
at any position,  
with any fingers

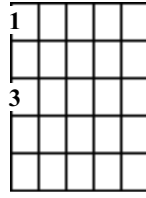

**whole step**  
may be on any string,  
at any position,  
with any fingers

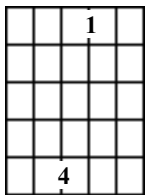

**a half step on two strings**  
may be on adjacent pair of strings  
*except NOT the second and third strings,*  
at any position, with any fingers  
(as long as you can reach!)

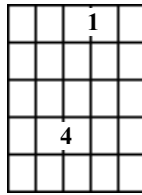

**whole step on two strings**  
may be on adjacent pair of strings  
*except NOT the second and third strings,*  
at any position, with any fingers  
(as long as you can reach!)

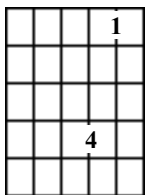

**a half step on two strings**  
the unique fingering  
on the second and third strings,  
at any position, with any fingers

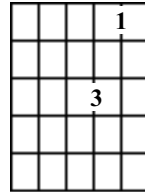

**whole step on two strings**  
the unique fingering  
on the second and third strings,  
at any position,  
with any fingers

## Numbering The Major Scale Tones

In the solfeggio system, the intervals of the major scale are labeled with the syllables “do, re, me, fa, sol, la, ti”. Here is a C major scale, played in the first position (with the first finger at the first fret) and labeled both with the solfeggio syllables and the numbers 1 through 7:

letter names: 1 2 3 4 5 6 7 1 1 7 6 5 4 3 2 1  
 solfeggio: do re me fa sol la ti do do ti la sol fa me re do

T 4  
 A 4  
 B 4

3 0 2 3 0 2 0 1 1 0 2 0 3 2 0 3



## Recognizing The Location Of The Half Steps In The Major Scale

In making up major scale fingerings, you should think of the notes by number, one through seven. Be aware that the half steps (one fret intervals) occur between numbered major scale tones 3 and 4 and between 7 and 1 (ascending in pitch). These scale steps are circled in the example above. The remaining steps of the major scale are whole steps apart, which include the intervals between the following pairs of numbered scale tones: “1 to 2”, “2 to 3”, “4 to 5”, “5 to 6” and “6 to 7”.

The intervals between the numbered tones of the major scale were illustrated earlier in the section on Major Scale Intervals, using the “string diagrams” shown below.

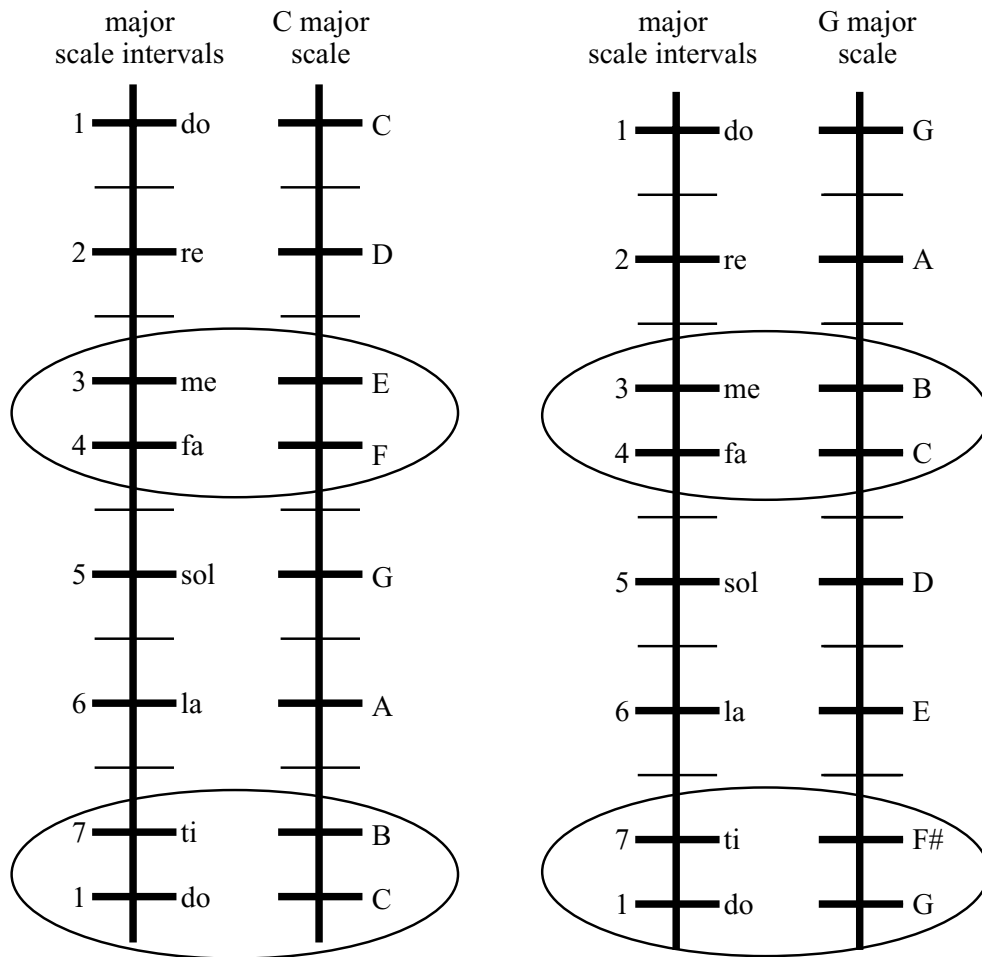

## Play A Major Scale On One String

This is an E major scale, named after “E”, the note on which it begins and ends. A traditional set of names for the notes of a major scale is “do, re, me, fa, sol, la, ti, do.” The eighth note has the same name as the first one and is referred to as being an *octave* higher than the first note. Speak their names of the notes below as you play them.

The tones of the major scale can also be labeled with the numbers “1, 2, 3, 4, 5, 6, 7, 1”. Again, the eighth note has the same name as the first one and is called an octave. Speak the numbers as you play the notes.

Notice that the distance between the tones are whole steps, except half steps between “3” and “4” and between “7” and “1” (where “1” begins the next octave).

## Memorize Seven Major Scale Fingerings

By memorizing these fingerings, you’ll be prepared to relate a major scale to any chord, anywhere on the fretboard. Pay close attention to the numbers between the tablature and the music notation for each note. These numbers indicate the steps of the major scale on which each note occurs. In each fingering, notice the half steps between “3” and “4” and between “7” and “1”,

In the numbering system shown at the left of each staff below (fingering 1, fingering 2, etc.), each fingering is numbered after the lowest reachable tone (by pitch) on the sixth string. This is emphasized by the circled numbers on the diagrams.

Numbers shown in parenthesis on the diagrams are optional third string fingerings for the same scale tone (by number) on the second string.

The text beneath the title of each fingering diagram (“reach with index finger”, “no reaches!”, etc.) describes which (if any) fingers should have to reach out of the range of four consecutive frets. These references do not necessarily include the optional notes on the third string.

fingerings 1  
reach with  
index finger

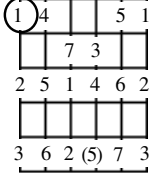

fingerings 2  
reach with  
index finger

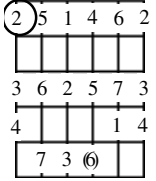

fingerings 3  
no reaches!

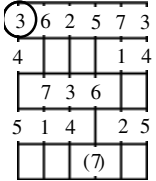

fingerings 4  
reach with  
index finger

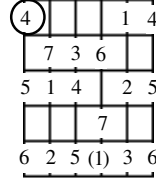

fingerings 5  
reach with  
index finger

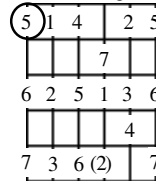

fingering 6

reach with little finger

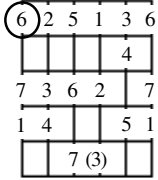

fingering 7

no reaches!

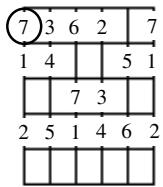

In order that you can refer to all seven fingerings on the same page, they are shown in diagram form below:

<p>fingering 1 reach with index finger</p>	<p>fingering 2 reach with index finger</p>	<p>fingering 3 no reaches!</p>	<p>fingering 4 reach with index finger</p>	<p>fingering 5 reach with index finger</p>	<p>fingering 6 reach with little finger</p>	<p>fingering 7 no reaches!</p>
--	--	------------------------------------	--	--	---	------------------------------------

# Constructing Major Scales

- **Strict Vertical Position**
- **Beginning A Major Scale From the Little Finger On the Sixth String**
- **Major Scale Fingering Numbers**
- **Beginning A Major Scale From the Index Finger On the Sixth String**

# Strict Vertical Position

## (primarily for single note playing)

Position is numbered after the fret at which your index finger is placed. In that position, the other three fingers are assigned one of the next three frets in-a-row toward the body of the guitar. In other words, each of the four fingers are assigned to one of four consecutive frets.

The examples below show the first string. The position numbers would be the same, regardless of which string the fingers were placed upon.

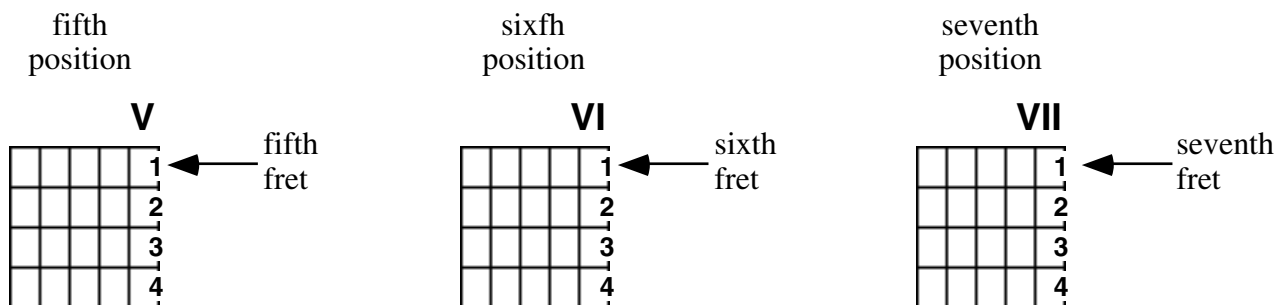

You can also reach one fret out-of-position with the index and little fingers:

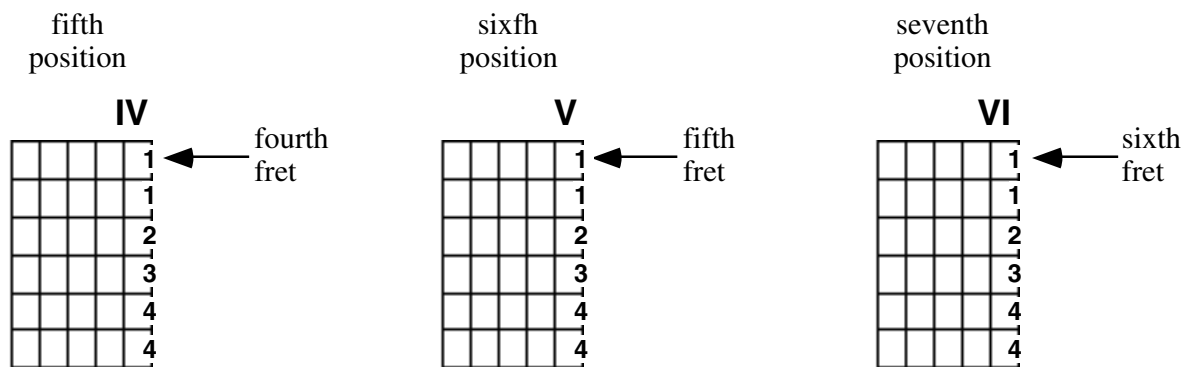

### QUIZ: In what position are each of the examples below?

Example 1

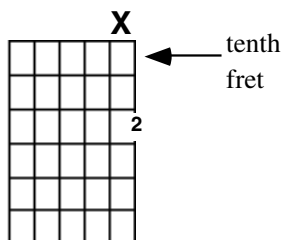

Example 2

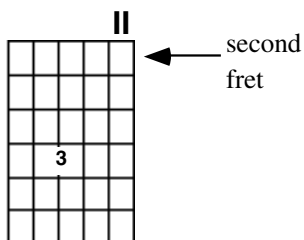

Example 3

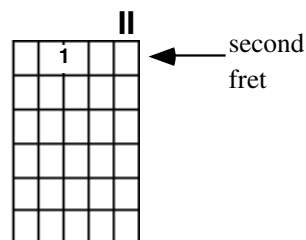

Example 1: eleventh position. Example 2: third position. Example 3: second OR third position. :srawsnu

# Beginning A Major Scale Fingering From The Little Finger On the Six String

Be careful not to change position. Position was defined above. Let's start in fifth position. Play the note at the sixth string, eighth fret and think of it as scale tone one:

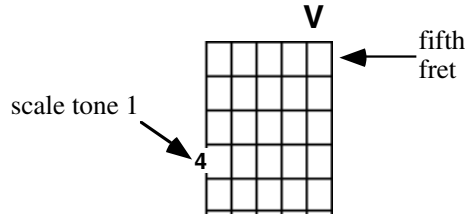

The interval from scale tone one to scale tone two should be a whole step. According to the fingering for a whole step shown in the previous section, a whole step above step one would be here:

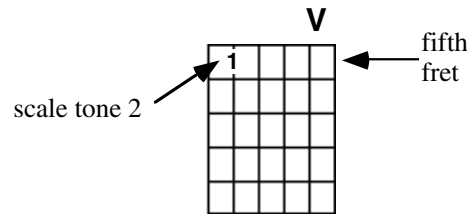

The interval from scale tone two to scale tone three should be a whole step. According to the fingering for a whole step shown in the previous section, a whole step above step two would be here:

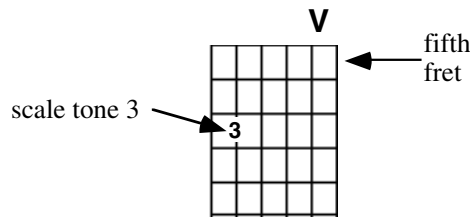

So far, you should have played this:

fingers: 4      1      3 scale tones: 1      2      3						
<table border="0" style="width: 100%;"> <tr> <td style="width: 33%;">T</td> <td style="width: 33%;">A</td> <td style="width: 33%;">B</td> </tr> <tr> <td style="text-align: center;">8</td> <td style="text-align: center;">5</td> <td style="text-align: center;">7</td> </tr> </table>	T	A	B	8	5	7
T	A	B				
8	5	7				

The interval from scale tone three to scale tone four should be a half step. According to the fingering for a half step shown in the previous section, a half step above step three would be here:

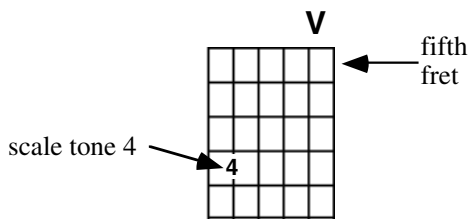

The interval from scale tone four to scale tone five should be a whole step. That would be here:

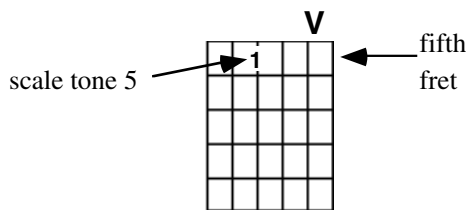

The interval from scale tone five to scale tone six should be a whole step. That would be here:

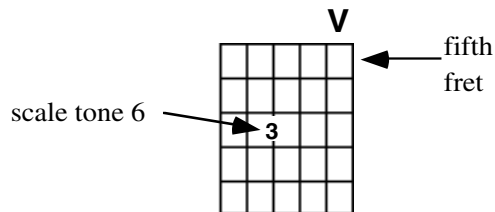

The interval from scale tone six to scale tone seven should be a whole step. According to the fingering for a half step shown in the previous section, that presents two options:

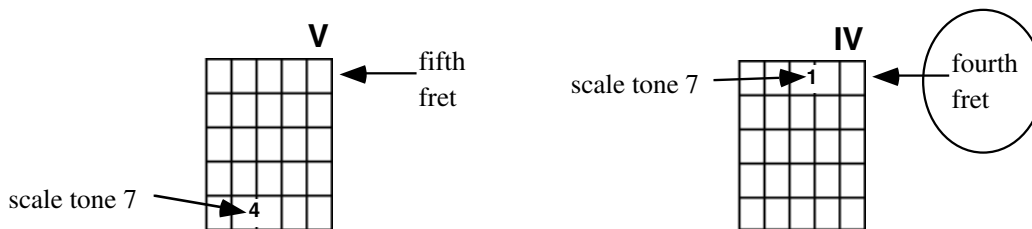

The interval from scale tone seven up to scale tone one should be a half step. If you chose the first finger option in fingering scale tone seven, don't fret scale tone one with the second finger (that would change position).

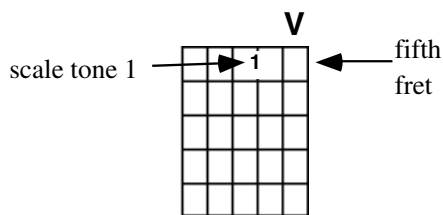



You should have come up with one of the fingerings below. The first version uses the little finger for scale tone seven, while the second version uses the little finger for both scale tones seven and one.

If you continue the fingering through the next octave higher, you should get the following:

Here is the entire two-octave fingering you have made:

Now begin the fingering again at the sixth string, eighth fret, scale tone “1” and descend as far as the position permits:

begin at  
scale tone 1

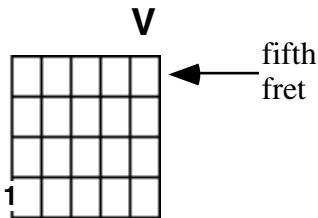

down a half step to  
scale tone 7

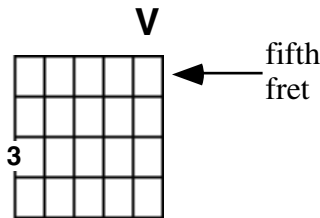

down a half step to  
scale tone 6

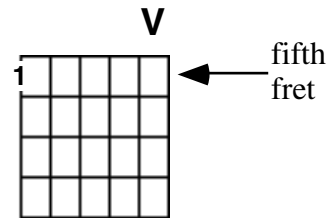

## Major Scale Fingering Numbers

I number major scale fingerings according to the number of lowest note fingered with the index finger on the sixth string. The fingering you have just made, is called major scale in-position fingering 6. Other fingerings called three-note-per-string major scale fingerings use slightly different rules regarding playing in position. The seven in-position fingerings are shown below. Scale tones are numbered. The scale tone numbers shown in parenthesis are options, where the same note can be fingered on the second string.

### In-Position Fingerings

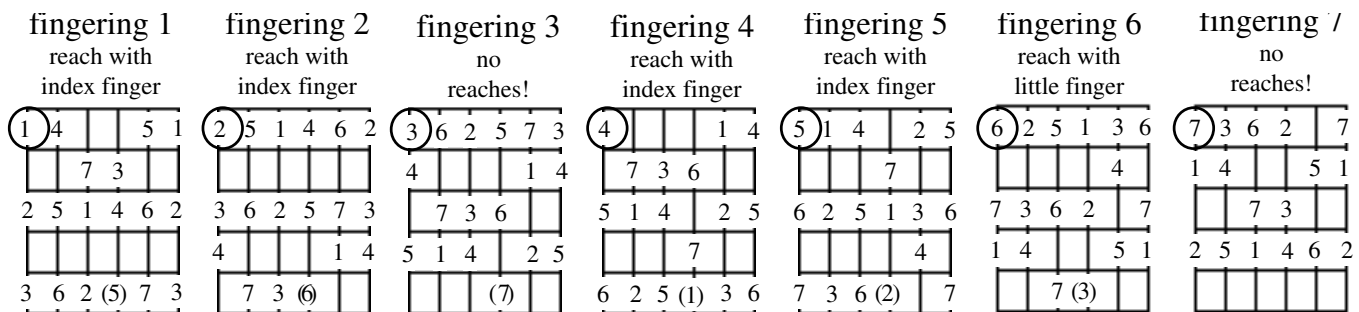

The in-position fingerings lend themselves to playing chord and arpeggio structures within the scale. Melody is largely an ornamentation of chord tones, so these fingerings work well to improvise. Three-note-per-string fingerings are better suited to playing scale runs, since picking can be the same for every string and the finger patterns are more repetitious and easier to recall. Here are the three-note-per-string major scale fingerings:

### Three Note-Per-String Fingerings

fingering 1/2	fingering 2/3	fingering 3/4	fingering 4/5	fingering 5/6	fingering 6/7	fingering 7/1

Three-note-per-string major scale fingerings shown above combine in-position fingerings, and are numbered accordingly. Fingering 1/2 combines in-position fingerings 1 and 2; fingering 2/3 combines in-position fingerings 2 and 3; and so on.

Let's get back to constructing in-position fingerings....

## Beginning A Major Scale Fingering From The Index Finger On the Six String

Be careful not to change position. Position was defined at the beginning of this chapter. Let's start in fifth position. Play the note at the sixth string, fifth fret and think of it as scale tone one:

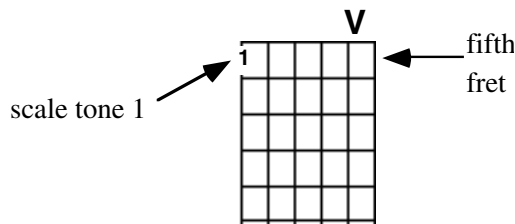

The interval from scale tone one to scale tone two should be a whole step. You may use the second or third fingers. If you use the second finger, you are in sixth position. If you use the third finger you are in fifth position.

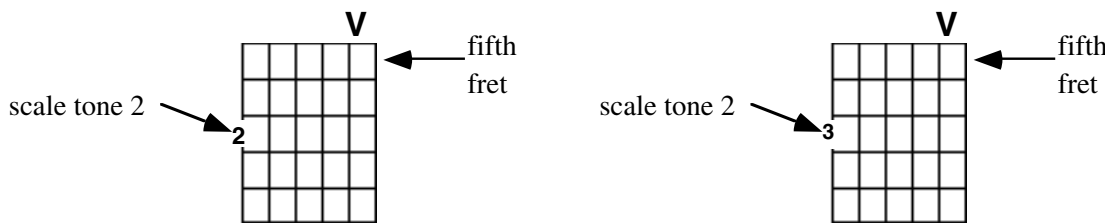

Using either the second or third fingers for scale tone “2”, you could use the fourth finger for scale tone “3”. This is shown in options 1 and 2, below:

*fingerings scale tones “1”, “2” and “3” with OPTION 1*

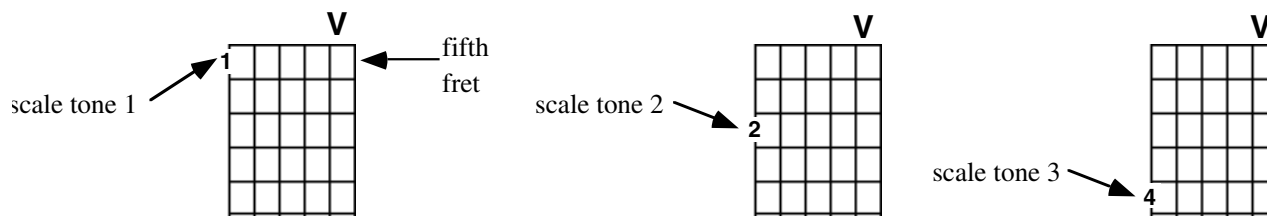

*fingerings scale tones “1”, “2” and “3” with OPTION 2*

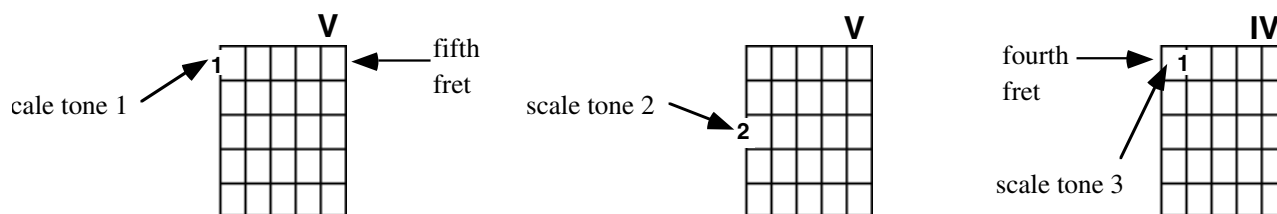

If you used the third finger for scale tone “2”, there is another option for scale tone three:

*fingerings scale tones “1”, “2” and “3” with OPTION 3*

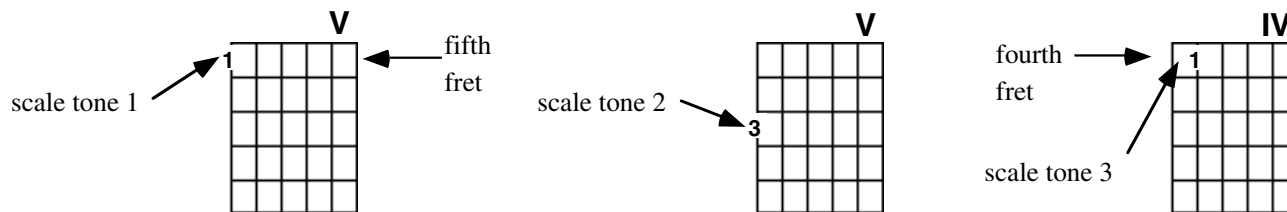

The interval from scale tone three to scale tone four should be a half step. Regardless of which option you used in fingering scale tones “1”, “2” and “3” (see above), scale tone “4” would be fingered the same:

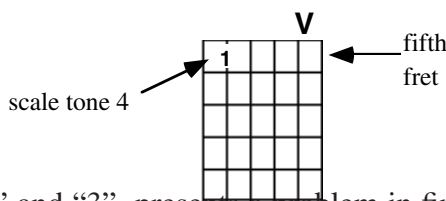

Using option 3 for scale tones “1”, “2” and “3” presents a problem in fingering two consecutive notes with the same finger, which can make it difficult to play through the scale quickly:

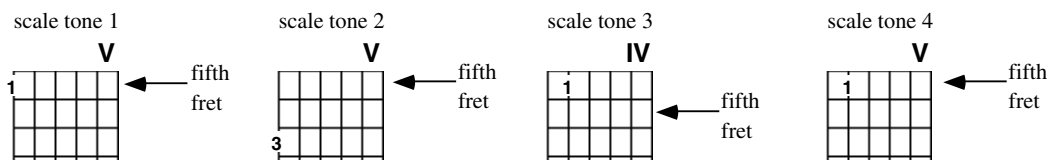



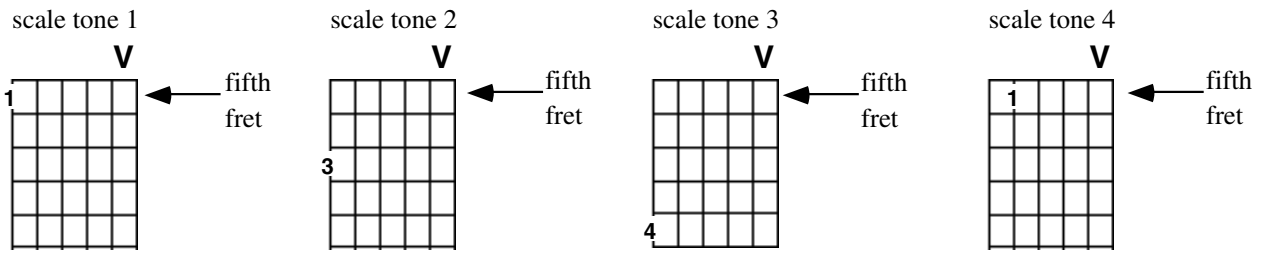

Using option 2 for scale tones “1”, “2” and “3” presents another problem in reaching scale tone “3” with the little finger, which can also make it difficult to play through the scale quickly:

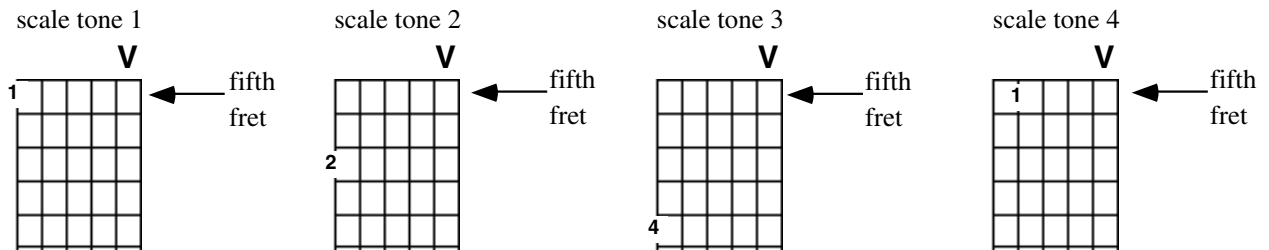

Using option 1 for scale tones “1”, “2” and “3” is best to play through the scale quickly. Remember, this choice has established your fingering as being in sixth position, with the index finger reaching out-of-position to the fifth fret and with the little finger reaching out-of-position to the ninth fret.

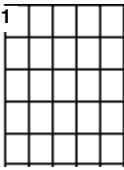
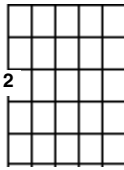

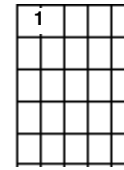
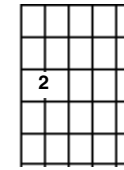
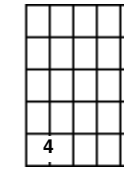
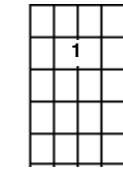
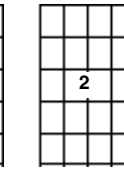
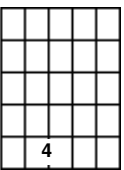
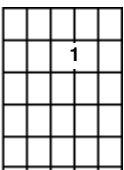
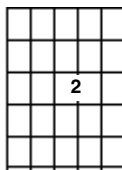
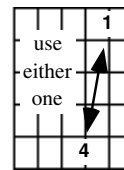
Continuing to construct the scale in sixth position would produce the fingering shown below.

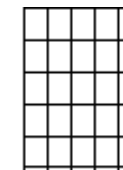
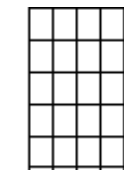
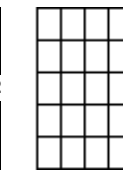
scale tone 1	scale tone 2	scale tone 3	scale tone 4	scale tone 5	scale tone 6	scale tone 7	scale tone 1	
<b>V</b>	<b>V</b>	<b>V</b>	<b>V</b>	<b>V</b>	<b>V</b>	<b>V</b>	<b>V</b>	
								
scale tone 2	scale tone 3	scale tone 4	scale tone 5	scale tone 6	scale tone 7	scale tone 1	scale tone 2	scale tone 3
<b>V</b>	<b>V</b>	<b>V</b>	<b>V</b>	<b>V</b>	<b>V</b>	<b>V</b>	<b>V</b>	<b>V</b>
								

Since the lowest pitch fingered on the sixth string with the index finger is scale tone “1”, this is called major scale in-position fingering 1. You should now try to construct all seven of the major scale in-position fingerings, which were shown in the previous chapter.

# Chord Construction Prep



- **The Intervals Necessary To Construct A Major Chord**
- **Perfect Fifth Fingerings**
- **Major Third Fingerings**
- **Perfect Fourth Fingerings**

# The Intervals Necessary To Construct A Major Chord

A major chord contains tones 1, 3 and 5 of a major scale on its chord root. You will need to know how to finger the intervals from the root ("1") to the each of the other chord tones. Play each of the major scale fingerings below. Next, isolate scale tones 1, 3 and 5 and play them in ascending and descending order. When you play major scale tones 1, 3 and 5, you are playing a major chord arpeggio named after the note on "1".

Notice that the "1" after which each major chord arpeggio is named occurs in one of five octave shapes. The octave shapes are shown by the circled notes below. Review Chapter 4: Octave Shapes.

fingering 1		fingering 2		fingering 3		fingering 4		fingering 5		fingering 6		fingering 7	
E form		D form		C form		A form		A Form		G form		E form	
↑		↑		↑		↑		↑		↑		↑	
the shape of the "1"s above matches the shape of the circled "E"s below		the shape of the "1"s above matches the shape of the circled "D"s below		the shape of the "1"s above matches the shape of the circled "C"s below		the shape of the "1"s above matches the shape of the circled "A"s below		the shape of the "1"s above matches the shape of the circled "A"s below		the shape of the "1"s above matches the shape of the circled "G"s below		the shape of the "1"s above matches the shape of the circled "E"s below	
↓		↓		↓		↓		↓		↓		↓	
E   I		D   I		C   I		A   I		A   I		G   I		E   I	

## Perfect Fifth Fingerings

Perfect fifth intervals are equal to the distance between major scale tones "1" and "5". If you locate the lower-pitched note of any perfect fifth fingering below as the number "1" in a major scale fingering, you should be able to locate "5" as the higher-pitched note in the fingering.



## Primary Perfect Fifth Fingerings

(compensated versions are shown at the right).

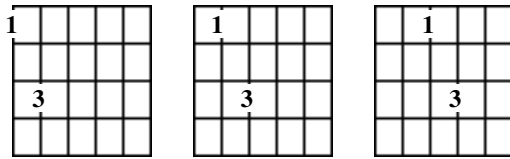

This primary perfect fifth fingering is compensated for tuning on the smallest two strings. Notes on the smallest two strings must relatively be moved up one fret (higher in pitch), when combined with the larger four strings..

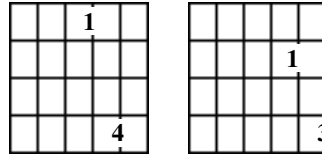

## Secondary Perfect Fifth Fingerings

(compensated versions are shown at the right)

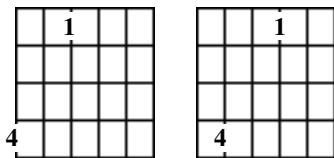

These secondary perfect fifth fingerings are compensated for the tuning on the smallest two strings. Notes on the smallest two strings must relatively be moved up one fret (higher in pitch), when combined with the larger four strings.

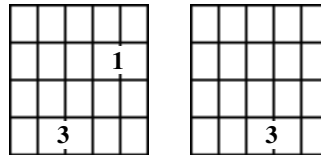

# Major Third Fingerings

Major third intervals are equal to the distance between major scale tones “1” and “3”. If you locate the lower-pitched note of any major third fingering below as the number “1” in a major scale fingering, you should be able to locate “3” as the higher-pitched note in the fingering.

## A Major Third Is Fingered The Same On Each String

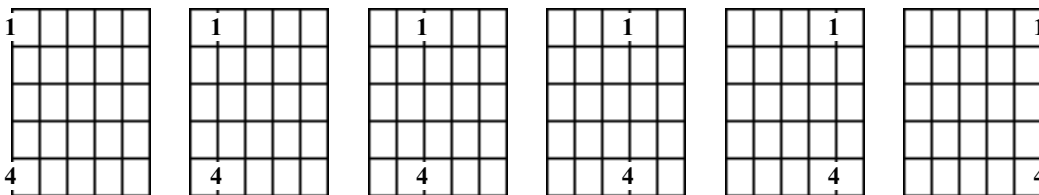

## Major Third Fretted On Adjacent Strings (note the unique fingering on the second and third string)

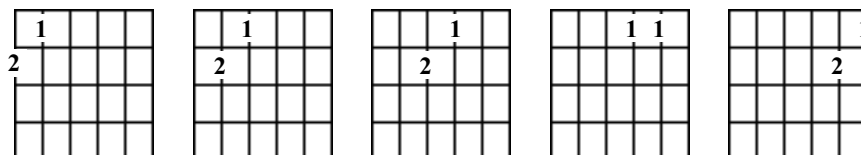

# Perfect Fourth Fingerings

In constructing a major chord, you'll often need to know a perfect fourth fingering to locate the fifth of the chord below the root. Perfect fourth intervals are equal to the distance between major scale tones "1" and "4". If you locate the lower-pitched note of any major third fingering below as the number "1" in a major scale fingering, you should be able to locate "4" as the higher-pitched note in the fingering. Perfect fourth intervals also occur in major scale fingerings between scale tone "5" and the next higher-pitched scale tone "1", where they demonstrate the relationship between the fifth ("5") and the root ("1") of a chord.

## Perfect Fourths Fretted On Adjacent Strings

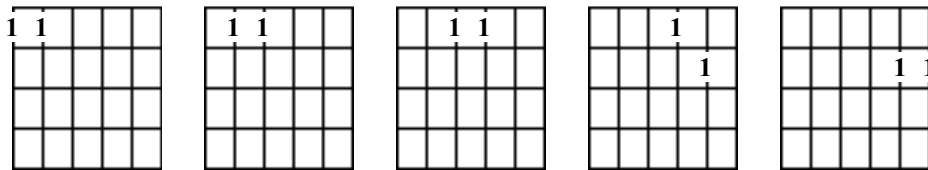

## Perfect Fourth Fingerings On Adjacent Open Strings

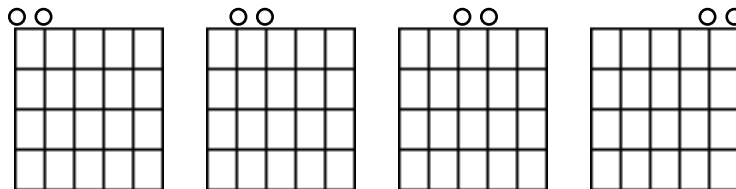

# Chord Formulas



- **What Are Chord Roots And Formulas?**
- **Chord Formulas By Family**

# What Are Chord Roots And Formulas?

## WHAT IS A CHORD ROOT?

A chord root is the note after which a chord is named. It is the letter which begins the chord name and any sharp or flat that may immediately follow it. “B” is the root of a Bm7b5 chord. “Bb” (B flat) is the root of a Bbm7b5 chord. “F” is the root of a Fma7b5 chord. “F#” is the root of an F#ma7b5 chord.

Aurally (in terms of sound), a chord root can also be thought of as the lowest note a listener can imagine during the playing of a chord. If the listener is experienced in recognizing chord inversions (where notes other than the root may be the lowest pitch), they should imagine in terms of root position, where the root is in the bass.

## WHAT IS A CHORD FORMULA?

A chord formula expresses the notes of a chord in relation to a major scale based on its chord root. It may indicate altered tones of the major scale. A flat symbol (  $\flat$  ) placed before any number in a chord formula indicates a note one half step lower than that numbered tone. A sharp symbol (  $\sharp$  ) placed before any number in a chord formula indicates a note one half step higher than that numbered tone. “  $\flat 3$  ” (flat three) would indicate a note one half step lower than scale tone “3”.

Memorizing chord formulas may not be so difficult as it may seem. The chords in each group, organized by type follows a pattern.

## Chord Formulas By Family

### Chord Name

### Formula

#### major

major .....	1	.....3	.....5
$\Delta 7$ (major seventh) .....	1	.....3	.....5 .....7
$\Delta 7\flat 5$ (major seventh flat five) .....	1	.....3	..... $\flat 5$ .....7
$\Delta 7\sharp 5$ (major seventh sharp five) .....	1	.....3	..... $\sharp 5$ .....7
$\Delta 9$ (major ninth) .....	1	.....3	.....5 .....7 .....9(=2)
$\Delta 9\sharp 11$ (major ninth sharp eleven) .....	1	.....3	.....5 .....7 .....9(=2)..... $\sharp 11$ (#4)
$\Delta 13\sharp 11$ (major thirteenth sharp eleven) .....	1	.....3	.....5 .....7 .....9(=2)..... $\sharp 11$ (#4) ...13
$\Delta 9\flat 5$ (major ninth flat five) .....	1	.....3	..... $\flat 5$ .....7 .....9(=2)
$\Delta 9\sharp 5$ (major ninth sharp five) .....	1	.....3	..... $\sharp 5$ .....7 .....9(=2)

**dominant**

7 (dominant seventh)	1	3	5	b7
9 (dominant ninth)	1	3	5	b7 9 (=2)
11 (dominant eleventh)	1	3	5	b7 9 (=2) 11 (=4)
13 (dominant thirteenth)	1	3	5	b7 9 (=2) 11 (=4) 13 (=6)
9/6 (dominant ninth, add six)	1	3	5	b7 9 (=2) 13 (=6)
13 n11 (dominant thirteenth, no eleven)	1	3	5	b7 9 (=2) 13 (=6)
7b5 (seventh flat five)	1	3	b5	b7
7#5 (seventh sharp five)	1	3	#5	b7
7b9 (seventh flat nine)	1	3	5	b7 b9 (=b2)
7#9 (seventh sharp nine)	1	3	5	b7 #9 (=2)
9b5 (ninth flat five)	1	3	b5	b7 9 (=2)
9#5 (ninth sharp five)	1	3	#5	b7 9 (=2)
7b5b9 (seventh flat five, flat nine)	1	3	b5	b7 b9 (=b2)
7b5#9 (seventh flat five, sharp nine)	1	3	b5	b7 #9 (=2)
7#5b9 (seventh sharp five, flat nine)	1	3	#5	b7 b9 (=b2)
7#5#9 (seventh sharp five, sharp nine)	1	3	#5	b7 #9 (=2)
7 sus.4 (seventh suspended fourth)	1	4	5	b7
9 sus.4 (ninth suspended fourth)	1	4	5	b7 9 (=2)
11 n3 (11th, no third)	1	4	5	b7 9 (=2) 11 (=4)

**minor**

minor	1	b3	5
m7 (minor 7th)	1	b3	5 b7
m9 (minor 9th)	1	b3	5 b7 9 (=2)
m11 (minor eleventh)	1	b3	5 b7 9 (=2) 11 (=4)
m13 (minor thirteenth)	1	b3	5 b7 9 (=2) 11 (=4) 13 (=6)
m9/6 (minor ninth, add six)	1	b3	5 b7 9 (=2) 13 (=6)
m13 n11 (minor thirteenth, no eleven)	1	b3	5 b7 9 (=2) 13 (=6)
m7b5 (Ø, Ø7 or half diminished)	1	b3	b5 b7
m (ma7) (minor major seventh)	1	b3	5 7
m (ma7)b5 (minor major seventh, flat five)	1	b3	b5 7
m9b5 (minor ninth flat five)	1	b3	b5 b7 9 (=2)

### diminished

diminished.....1 .....b3 .....b5  
 $^{\circ}7$  (diminished seventh).....1 .....b3 .....b5 .....bb7 (=6)  
 $^{\circ}7/9$  (diminished seventh, add nine).....1 .....b3 .....b5 .....bb7 (=6)...9(=2)

### augmented

aug. (augmented).....1 .....b3 .....b5  
 $\Delta 7^+$  (major seventh augmented) .....1 .....3 .....#5 .....7  
 $\Delta 9^+$  (major ninth augmented) .....1 .....3 .....#5 .....7 .....9 (=2)  
 $7^+$  (seventh augmented).....1 .....3 .....#5 .....b7  
 $9^+$  (ninth augmented) .....1 .....3 .....#5 .....b7 .....9 (=2)

### add tone

$/9$  (add nine) .....1 .....3 .....5 .....9 (=2)  
 $m/9$  (minor add nine) .....1 .....b3 .....5 .....9 (=2)  
 $6$  (sixth or major sixth) .....1 .....3 .....5 .....6  
 $m6$  (minor sixth).....1 .....b3 .....5 .....6  
 $6/9$  .....1 .....3 .....5 .....6 .....9 (=2)  
 $m6/9$  .....1 .....b3 .....5 .....6 .....9 (=2)  
 $7/6$  (dominant seventh, add six) .....1 .....3 .....5 .....b7 .....6  
 $9/6$  (dominant ninth, add six) .....1 .....3 .....5 .....b7 .....9 (=2)  
 $m7/6$  (minor seventh, add six) .....1 .....b3 .....5 .....b7 .....6  
 $m9/6$  (minor ninth, add six) .....1 .....b3 .....5 .....b7 .....9 (=2)  
 $/11$  (add eleven or major add eleven) .....1 .....3 .....4 .....5  
 $m/11$  (minor add eleven).....1 .....b3 .....4 .....5  
 $m7/11$  (minor seventh, add eleven) .....1 .....b3 .....4 .....5 .....b7  
 $7/11$  (dominant seventh, add eleven) .....1 .....3 .....4 .....5 .....b7

### suspended

sus. 4 (suspended fourth).....1 .....4 .....5  
sus. 2 (suspended second).....1 .....2 .....5  
 $7$  sus.4 (seventh suspended fourth) .....1 .....4 .....5 .....b7  
 $9$  sus.4 (ninth suspended fourth) .....1 .....4 .....5 .....b7 .....9 (=2)  
 $\Delta 7$  sus. 4 (major seventh, suspended fourth) ...1 .....4 .....5 .....7

# Constructing Major Chords

- **Common Major Chords By Octave Shape**
- **Reference Roots And Octaves**
- **Constructing Major Chords From The Root**

# Common Major Chords By Octave Shape

Numbers on the diagrams below indicate fingers, except on the large diagram at the right, where they indicate chord tones. Numbers below the diagrams below indicate scale tones.

The diagrams below illustrate most common major chord fingerings. Look at one of the diagrams and try to justify the numbered intervals you see, based on the interval fingerings you learned earlier. Here are some things to look for:

- The interval from “1” up to “3” (to “3”, higher in pitch) should be a major third.
- The interval from “1” up to “5” should be a perfect fifth.
- The interval from “5” up to “1” should be a perfect fourth.

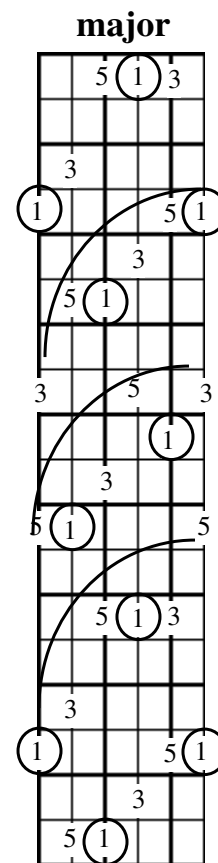
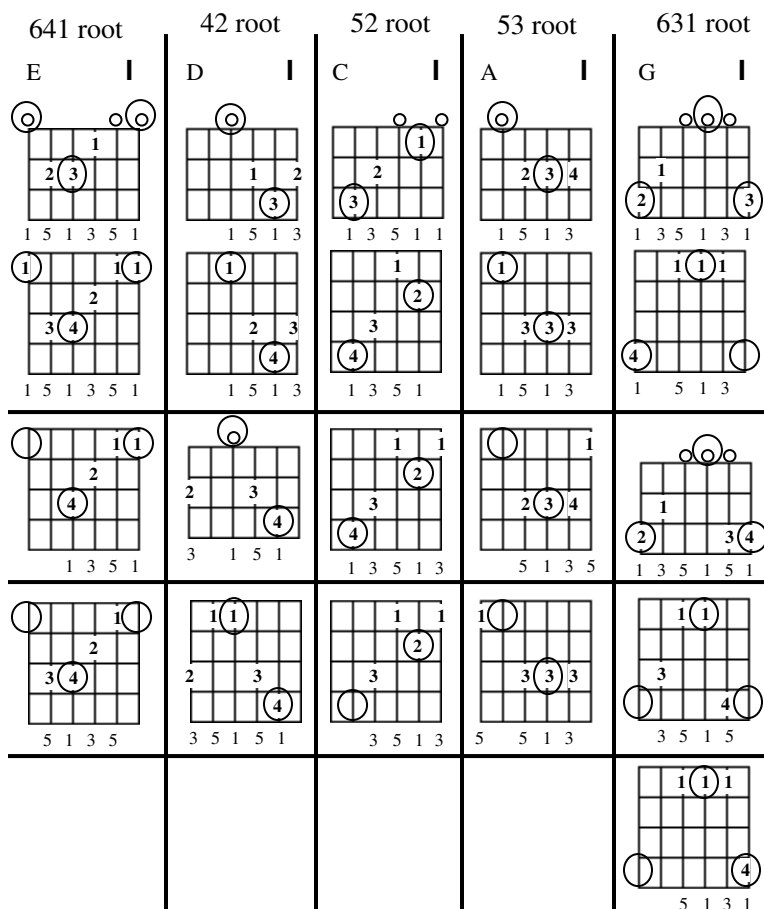



# Reference Roots and Octaves

## REFERENCE ROOTS

In some cases, you have no knowledge of the interval relationship to the root and will need to generate a “reference” root an octave below or above the one used in the chord. In the example below, a reference root was added below the lowest root in the chord, to be able to calculate the third (“3”) on the sixth string.

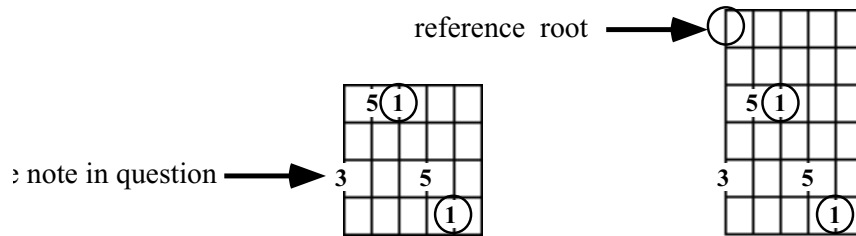

In the next example, a reference root was added in the octave above the chord root, to be able to calculate the third (“3”) on the first string.

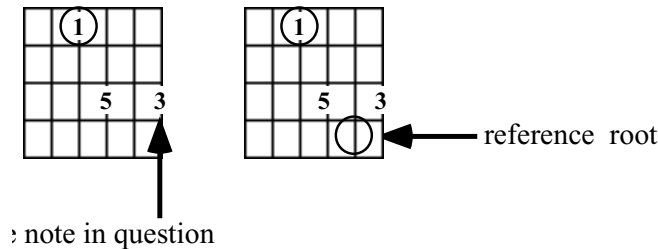

## REFERENCE OCTAVES

Another way to calculate a major chord tone for which you have no knowledge of the interval relationship to the root is to generate an octave in close proximity to a chord root. In the example below, the note in question was generated just above one of the chord roots (“1”), so it could be recognized as a major third (“3”).

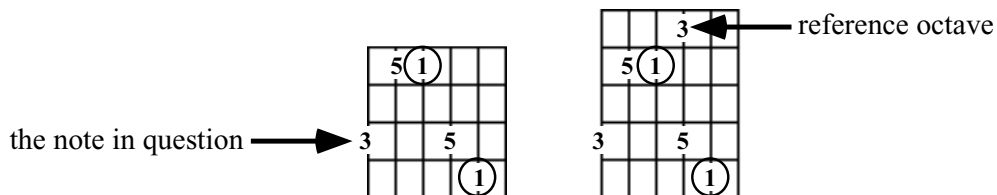

In the next example, the note in question was generated just above the chord root (“1”), so it could be recognized as a major third (“3”).

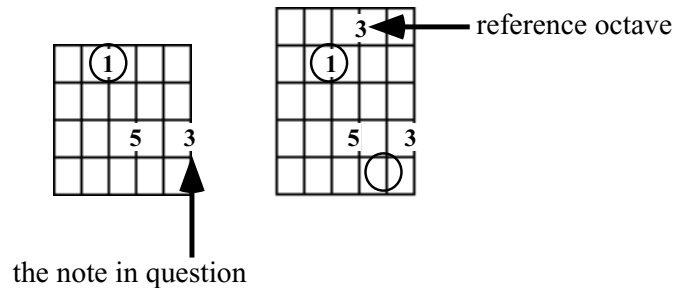

## Constructing Major Chords From The Root

In each example below, you are given a note which will be a chord's root. Then I'll go through the thought process of constructing the rest of a major chord, one note at a time. In addition to the root (“1”), each chord will need a third (“3”) and a fifth (“5”). Roots are circled. For the four examples below, numbers within the diagrams indicate the root, third and fifth.

### ROOT ON THE FOURTH STRING

Read the diagrams from left to right to see the chord accumulate. The root (“1”) appears on the fourth string. In the second diagram, the third appears on the third string, expressing the major third interval fingering shown earlier. In the third diagram, the interval from scale tone “5” up to scale tone “1” is a perfect fourth and the fingering for those two numbered tones matches what you were shown earlier in fingerings for a perfect fifth.

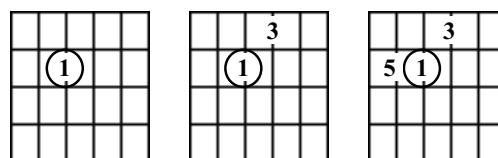

### Root On The Third String

Read the diagrams from left to right. The root (“1”) appears on the third string. In the second diagram, the third appears on the second string, using the unique major third fingering for adjacent strings found on the second and third strings. In the last diagram, the interval from scale tone “5” up to scale tone “1” is a perfect fourth, which justifies the placement of the “5” in the last diagram.

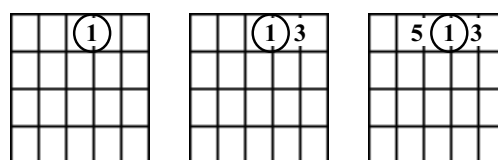

## Root On The Fourth String

Read the six diagrams from left to right.

**Diagram 1:** the root (“1”) appears on the fourth string.

**Diagram 2:** the third (“3”) appears on the third string, using the major third fingering for adjacent strings.

**Diagram 3:** a perfect fifth fingering locates the chords fifth (“5”) on the second string.

**Diagram 4:** for another fifth (“5”), a note is fingered a perfect fourth below the root on the (“5”) on the fifth string

**Diagram 5:** for another root (“1”), a note is fingered an octave above the root on the first string.

**Diagram 6:** for another root (“1”), a note is fingered an octave above the (fourth string) root on the sixth string

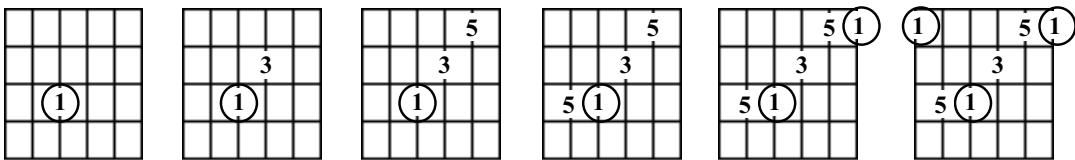



# The Root ID System



- **What Is Strict Vertical Position?**
- **What Are Chord Roots, Tone Centers, Keys And Chord Progression?**
- **What Is A Root ID?**
- **Combining Root IDs**
- **Why Can't I Just Use The Octave Shapes Instead Of The Root ID?**

## Welcome To The Root ID System

The root identification system becomes necessary when you begin to learn fingerings in-between the five octave shapes on in-between the seven major scale fingerings.

### Abbreviations used in this chapter:

“Root identification” will be abbreviated: “root ID”. “Strict vertical position” will be abbreviated: “SVP”

## What Is Strict Vertical Position?

In short, SVP defines where your fretting hand is located by specifying the fret at which your first finger is hovering or fretting. It applies to single note playing, not chording. It may change as often as once per note. Here are more specific rules about SVP:

- Four consecutive frets are strictly fretted with the index through little fingers, one each fret.
- The index finger may reach one fret to a lower-pitched note (toward the head of the guitar).
- The little finger may reach one fret to a higher-pitched note (toward the bridge of the guitar).

The root ID system identifies each of twelve unique SVPs in which to play any scale or other sequence of notes. The root ID system allows you to use the same fingering pattern in a new key. When changing a note sequence to another key, the SVP that occurred for each part of the sequence can be located in a new SVP, using the root ID as a reference.

## What Are Chord Roots, Tone Centers. Keys and Chord Progression?

### What Is A Chord Root?

A chord root is the lowest note you can imagine in the sound of a chord. It is the letter after which a chord is named. The letter name of a chord may be followed by a sharp or flat, such as G# or Gb. The sharp symbol indicates a note is played a half step (one fret) higher and a flat indicates it is played a half step lower.

Usually, the notes of a chord can be transposed by octaves to be arranged in consecutive thirds. When a chord is arranged entirely in thirds, the lowest note is usually the root. The first chord below has a “C” note in the bass. When the notes are arranged in thirds, which would be all notes on lines or all on spaces, “F” is the root.

Fma7	Fma7

In some cases, the root is not the lowest note in a series of thirds. Sixth chords have their root as the second-to-lowest tone in a series of thirds. With sixth chords, the lowest root you can imagine may indicate a different root. In the example below, the lowest imaginable root for the D6 chord could be heard as “B”, making the chord a Bm7.

Bm7	D6

### What Is A Tone Center?

A tone center is the root of the chord you would expect a piece to end on. You would expect a chord progression to end on a chord which gives a feeling of resolution. That chord would be the tonic chord, or main chord in the progression. If the tonic chord is Cm7, the tone center is “C.” If the tonic chord is “Ebm”, the tone center is “Eb.”

The tonic chord (or “main chord”) is the chord you would expect the piece of music to end on. It is the chord which sounds most resolved in a piece of music. A tonic chord is used to give the most final sound at the end of a piece.

I said “you would expect” the piece of music to end on the tonic chord in the previous paragraph, because although the listener expects a song to end on the tonic chord, it doesn’t have to. A song can end with a deceptive cadence (chord sequence) where the final chord is not the tonic chord. This type a ending is intended to “trick” the listener. Although a deceptive cadence does not produce as strong a feeling of resolution, it still can be stimulating. Likewise, songs often begin on the tonic chord, but they don’t have to.

Many recorded pieces of music have a “fade- out” ending. No distinct ending chord is played with a fade-out. I have always hated fade-out endings. I much prefer hearing the ending the band or artist would play in a live performance. The only exception would be where there is some point to fading out, such as the main character in the lyric is walking off into the woods or something of that nature.

**The tonic chord can be established by a number of elements in the chord progression, including:**

- Long duration or frequent occurrence of the intended tonic chord.
- A progression of chord roots up or down a scale to the root of the intended tonic chord.
- Chord root movement to the intended tonic chord from a scale step above or below, from a perfect fourth below, or from a perfect fifth above.
- Preceding the intended tonic chord by one or more dissonant, tension producing chords.
- Use of the root of the intended tonic chord as a repeating note through a series of chords. This is called a pedal tone and usually occurs in the bass.
- Progressions are typically built with groups of two or four bars. Ending with the desired tonic chord establishes stronger tonality than beginning with it, especially where the tonic chord begins the third or fifth bar.
- Use a tonic chord built on the first step of a historically established scale. The scales which are traditionally used more often produce a stronger tonality, because they are familiar to the listener.
  - a. The main chord usually has a strong tonality (is easy to establish as the main chord) in major, Dorian, Mixolydian or Aeolian mode (when major, Dorian, Mixolydian or Aeolian scales are used), in harmonic minor, or in Phrygian major mode (Phrygian scale with a major third).
  - b. The main chord has a passive tonality (somewhat difficult to establish as a main chord) in Phrygian or Lydian mode (when Phrygian or Lydian scales are used).
  - c. The main chord has a weak tonality (quite difficult to establish as the main chord) in Locrian mode (when Locrian scale is used).
- Use the root of the main chord in a low range of pitch.

**Key**

A song is said to be in a key named after the tone center. If the tone center is “A”, the song is said to be in the key of “A”. The key may be further qualified by the scale or mode type, such as “A” major, “A” minor or “A” Mixolydian.

The term “minor” is often used loosely in key names where the song may be in any mode which has a minor chord built on the tone center (e.g., Aeolian or harmonic minor). Likewise, the term major is sometimes used in reference to any mode which has a major chord built on the tone center (e.g., Mixolydian or Phrygian major).

In the example below, the Am chord sounds resolved at the end. The piece is in the key of A minor.



Musical notation for a piece in A minor. The top staff shows a melody in treble clef with a key signature of one flat. The bottom staff shows guitar fretting for Treble (T), Middle (A), and Bass (B) strings. The final chord is labeled "Am".

Elsewhere, in the same piece of music, the section below appears. It has a sense of temporarily being in the key of E major (the specific scale it uses is E Mixolydian flat six, but the tonic chord is E, and the primary sound of the scale is E major). The E major chord sounds somewhat resolved at the end of the example, but you might get the sense that the melody is going back to the key of A minor afterward (play the example below, then the example above).

Musical notation for a piece in E major. The top staff shows a melody in treble clef with a key signature of two sharps. The bottom staff shows guitar fretting for Treble (T), Middle (A), and Bass (B) strings. The final chord is labeled "E".

## Chord Progression

A chord progression is any sequence of chords. Typically, a chord progression is repeated during a piece of music. Each section of the piece of music (verse, chorus, etc.) may use a different chord progression. There may be different versions of each chord progression.

## What Is A Root ID?

The root ID specifies the string and finger which are involved in the fretting the chord root or tone center in its lowest octave for the current strict vertical position (SVP). The root ID consists of a number representing the string, followed by a hyphen and a number representing the finger. Sometimes, an “L” is added at the end to represent the index finger reaching one fret “low” (toward the head of the guitar).

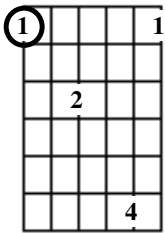
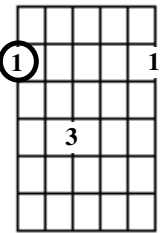
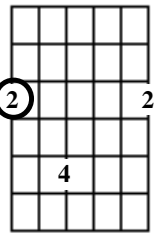
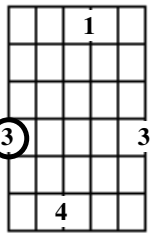
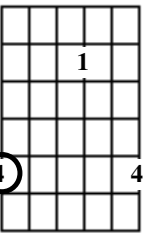
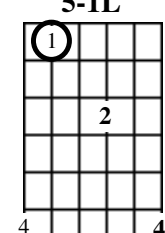
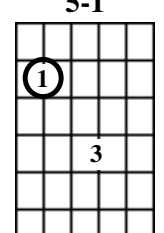
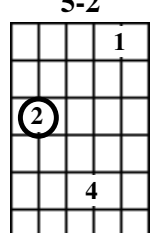
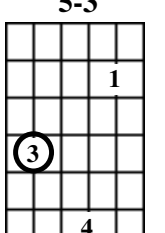
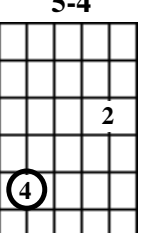
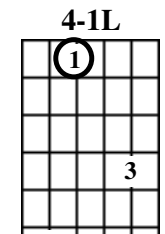
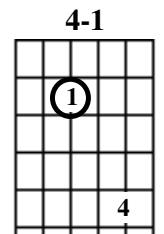
octaves from the sixth string	<b>6-1L</b> 	<b>6-1</b> 	<b>6-2</b> 	<b>6-3</b> 	<b>6-4</b> 
octaves from the fifth string	<b>5-1L</b> 	<b>5-1</b> 	<b>5-2</b> 	<b>5-3</b> 	<b>5-4</b> 
octaves from the fourth string	<b>4-1L</b> 	<b>4-1</b> 			

**Root IDs are named after the lowest pitch in each octave shown above as follows:**

- 6-1L has the lowest pitch fingered on the 6th string, with the 1st finger reaching one fret Low in pitch.
- 6-1 has the lowest pitch fingered on the 6th string, with the 1st finger.
- 6-2 has the lowest pitch fingered on the 6th string, with the 2nd finger.
- 6-3 has the lowest pitch fingered on the 6th string, with the 3rd finger.
- 6-4 has the lowest pitch fingered on the 6th string, with the 4th finger.
- 5-1L has the lowest pitch fingered on the 5th string, with the 1st finger reaching one fret Low in pitch.
- 5-1 has the lowest pitch fingered on the 5th string, with the 1st finger.
- 5-2 has the lowest pitch fingered on the 5th string, with the 2nd finger.

- 5-3 has the lowest pitch fingered on the 5th string, with the 3rd finger.
- 5-4 has the lowest pitch fingered on the 5th string, with the 4th finger.
- 4-1L has the lowest pitch fingered on the 4th string, with the 1st finger reaching one fret Low in pitch.
- 4-1 has the lowest pitch fingered on the 4th string, with the 1st finger.

### **Playing In A Single Root ID in Strict Vertical Position**

By choosing a root ID for a scale or arpeggio and playing it in strict vertical position (SVP), you isolate one of the twelve possible fingerings.

**A root ID played in a strict vertical position will be abbreviated “root ID/SVP”.**

After studying each of the twelve root ID/SVPs you can begin combining them in ways described below.

### **Playing One Tone Center Or Chord Root In All Twelve Root ID/SVPs**

It is beneficial to explore each scale and arpeggio (an arpeggio is a chord played one note at a time) in all twelve SVPs (strict vertical positions), each defined by a root ID.

Study each root ID/SVP thoroughly, not combining it with adjacent positions. You’ll find each root ID/SVP has certain advantages and disadvantages. The same notes can be slurred (slurs include hammer, pull-off, slide and bend) in one root ID/SVP and not in another. Shapes of some note sequences are easy to play in certain root ID’s.

By studying all twelve root ID fingerings for scales and arpeggios, it enables you to play one key in all twelve positions or all keys in one position. Freedom! Each root ID/SVP has advantages where certain notes can be more easily slurred, fretted or picked.

When an arpeggio involves one note on each string and proceeds across the strings in such a way that a lower-numbered fretting finger is used on each lower-numbered string, it is easy to coordinate the picking and fretting. When an arpeggio or scale involves the same fingering pattern on two or more consecutive strings, the brain has to do a lot less work.

In playing on quick chord changes, you may not have time to change position, and may have to improvise in a single position or at least a small area of the fretboard.

# Combining Root ID's

Once you are familiar with a few consecutive root ID/SVPs for a particular arpeggio or scale, start combining them. The most useful combination is probably the major scale fingerings. Diagrams are shown below for major scale fingerings in all twelve root ID/SVPs, followed by "three note-per-string" versions which combine them. The three note-per-string fingerings are easy to pick with economy picking, where you pick in the direction of each new string you move to, causing the picking to be identical for each string.

## Major Scale Fingerings in All Twelve Root ID/SVP's

Notice that for five of the seven major scale fingerings, there are two alternate root ID versions. The top row of diagrams show the notes by major scale tone number. The bottom two rows of diagrams show the fretting hand fingers by number.

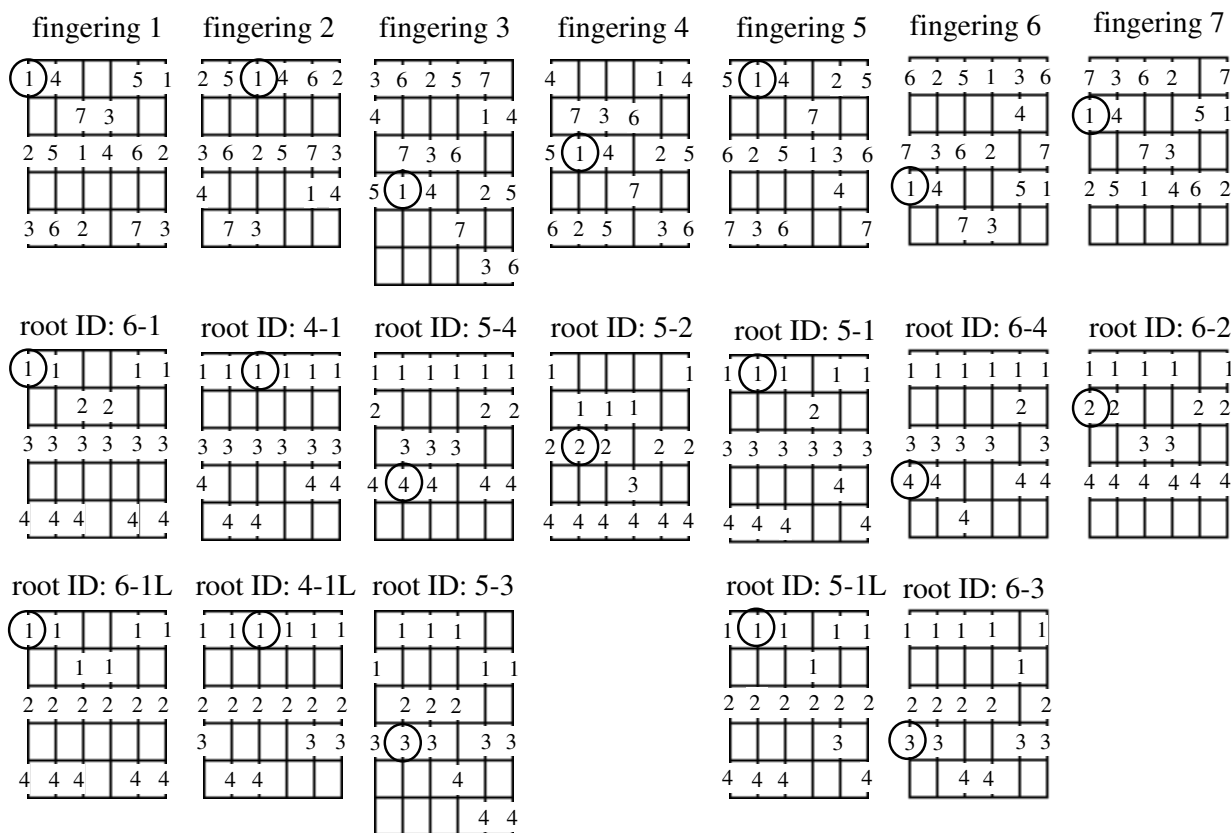

## Combining The In-Position Major Scale Fingerings To Make Three Note-Per-String Fingerings

Compare the fingerings below with the in-position fingerings above, by root ID. The top row of diagrams show the notes by major scale tone number. The bottom two rows of diagrams show the fretting hand fingers by number.

fingering 1/2  
root ID: 6-1L  
and 4-1

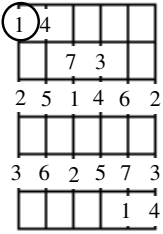

fingering 2/3  
root ID: 4-1L  
and 5-4

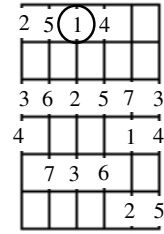

fingering 3/4  
root ID: 5-4  
and 5-3

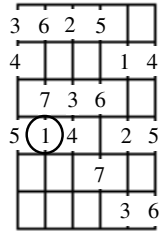

fingering 4/5  
root ID: 5-2  
and 5-1

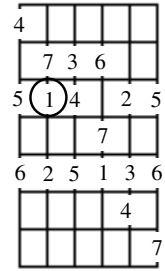

fingering 5/6  
root ID: 5-1L  
and 6-4

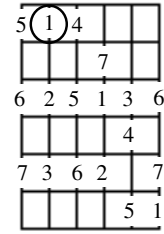

fingering 6/7  
root ID: 6-3  
and 6-2

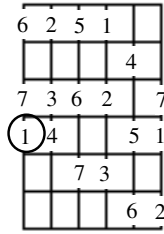

fingering 7/1  
root ID: 6-2  
and 6-1

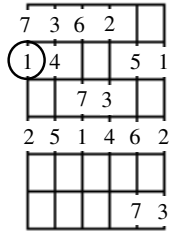

fingering 1/2  
root ID: 6-1L  
and 4-1

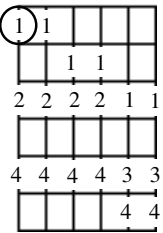

fingering 2/3  
root ID: 4-1L  
and 5-4

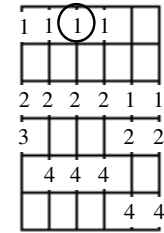

fingering 3/4  
root ID: 5-4  
and 5-3

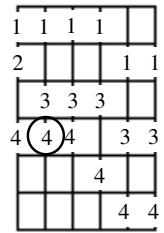

fingering 4/5  
root ID: 5-2  
and 5-1

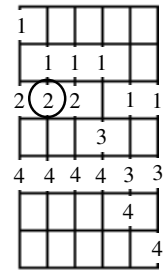

fingering 5/6  
root ID: 5-1L  
and 6-4

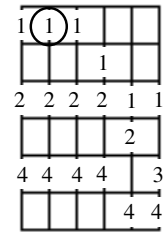

fingering 6/7  
root ID: 6-3  
and 6-2

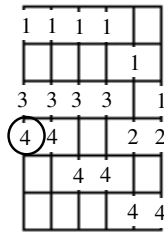

fingering 7/1  
root ID: 6-2  
and 6-1

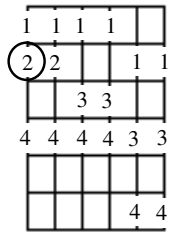

## Why Can't I Just Use The Octave Shapes Instead Of The Root ID?

You should use the octave shapes first. Once you learn arpeggios and scales in each of five octave shapes, you should explore the remaining possibilities. That's what the root ID system is all about.



# Principles Of Fingering



- **General Rules**
- **Changing Position**
- **Out-Of-Position Notes**

## General Rules

- When one rule conflicts with another, weigh the advantages and disadvantages of each.
- Practice difficult fingerings such as:
  - reaching out of position with the fourth finger,
  - rapid use of the fourth finger,
  - spans leaving a fret between the second (middle) and third (ring) fingers,
  - consecutive use of the same finger on different strings
  - wide skips in position.
- Avoid difficult fingerings when speed or clarity is needed. Use smooth, easy fingerings for speed and clarity. This often involves avoiding use of the little finger.
- Avoid using the second and third fingers spanned apart to leave an empty fret between them Exception: Allan Holdsworth's style incorporates this commonly avoided span.
- Avoid using the same finger for two different notes on the same string, unless to slide, change position, or reach out of position.
- Avoid using the same finger on different frets of two adjacent strings:

## Changing Position.

Avoid changing position until you have to when improvising diagonally across the fretboard. Continue using a convenient fingering area until it presents a difficulty. This simplifies your position changes.

### SHIFTING AND SLIDING

Changing position by playing two consecutive notes on the same string with the same finger.. When this is done without applying pressure, it is a *shift*. When it is done with sustained pressure, it is a *slide*. This is usually done with the first or fourth fingers, sometimes with the third finger.

When performing a shift, glide along the strings with some of your fingers to retain your orientation. Don't use enough pressure to create a sound.

### SKIPPING

Skipping from one position to another wastes time in movement, but can save time by using familiar fingering patterns which require little thought.

### COMPRESSING

Compressing is changing position where two non-consecutive fingerings fret notes over fewer frets than the span of fingers involved.



## **Out-Of- Position Notes**

Reach out of position with the outside fingers. Out-of-position notes can usually be reached with the first finger or with the little finger.

### **Guidelines for fingering out-of-position notes:**

- First finger out-of-position reaches are better than those with the fourth finger, because of the wider span between the first and second fingers.
- When playing intervals involving five fret spans on two or more strings, choose a fingering option with a whole step between the first and second finger. Otherwise, the whole step will probably occur between the third and fourth fingers.
- Identical fingering patterns on adjacent strings are desirable for ease of memorization and to conserve motion in the fretting hand.
- Hammers and pull-offs sometimes determine which out of position version of a note will be used.



# Constructing Arpeggios

- **Overview**
- **Memorize Reference Arpeggios**
- **Choose A Position**
- **Construct A Major Scale**
- **Access The Chord Formula**
- **Identify All Chord Tones**
- **Major Arpeggios In All Twelve Positions**
- **Deriving All Arpeggios From Major**

## Overview

To be adept at constructing chords and improvising with arpeggio tones, you need an awareness of all arpeggio tones for a chord in each area of the fretboard where you intend to work. Here is an overview of effective procedure:

- Memorize major arpeggios in each of five octave shapes, for reference.
- Choose an area of the fretboard, which will determine a strict vertical position (SVP).
- Construct a major scale for the complete range of the SVP.
- Access the chord formula.
- Identify the location of all chords tones in the SVP.
- Construct arpeggios in all twelve positions.
- Derive all other arpeggios from major arpeggios.

## Memorize Reference Arpeggios

### MEMORIZE F MAJOR CHORDS IN FIVE OCTAVE SHAPES

Fret each of the open string chords below (C, G, D, A and E) with the fingers shown. The numbers within the diagrams indicate fretting hand fingers. By not using the index finger, it can be reserved for barred versions of the same chords. Each of the “F” chords shown below is in the “form” of the chord above it. The “F” chord in first position is in “E” form. The “F” chord in III position is in “D” form, and so on.

### Using The Index Finger As A Capo

By “saving” the first finger for barreing the chords in the bottom row below, you are effectively using the index finger as a capo.

### Notice The “Empty” Fret

The first fret is “empty”, or not fretted on the D, A and G chords. The barred versions of those chords should also have an “empty” fret above (toward the guitar body) the index finger.

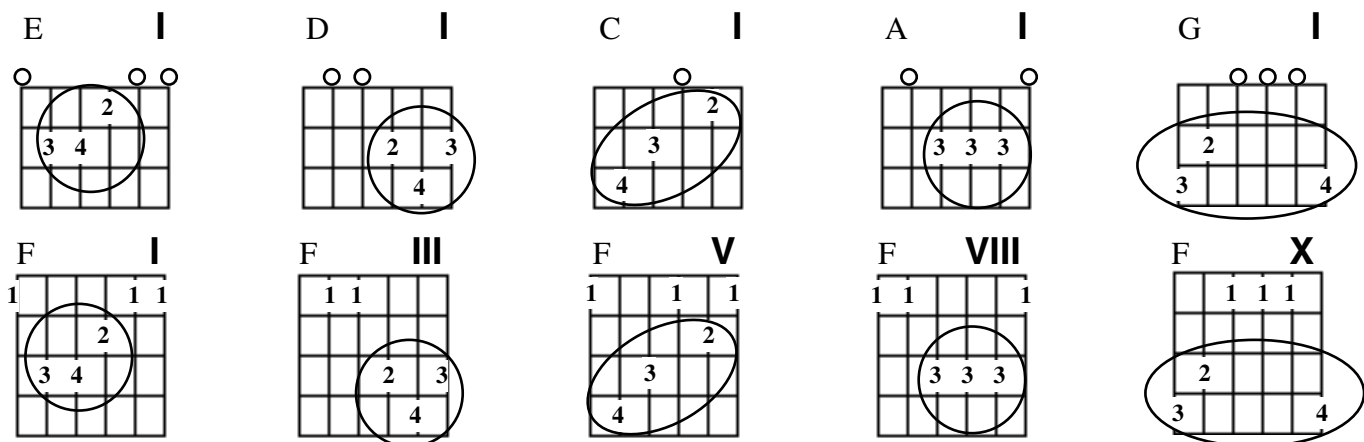

## MEMORIZE F MAJOR ARPEGGIOS IN FIVE OCTAVE SHAPES

Each of the arpeggios shown at the right below involves one or two notes added to the chord fingering (shown in the chord diagram to the left of each arpeggio diagram). The numbers in the diagrams are fretting fingers. Play the arpeggios in order of pitch. If you are not sure how to do this, refer to the sequence of diagrams on the next page.

### Add Tones To The E Form F Chord

The numbers in the diagrams are fretting fingers. Add the notes fretted with the little fingering to those of the F chord in first position (shown in the oval). Also, fret the note on the fourth string with the

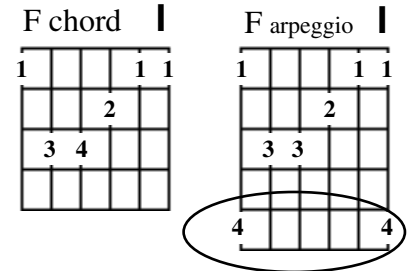

### Add Tones To The D Form F Chord

The numbers in the diagrams are fretting fingers. Add the notes shown in the oval to those of the “F” chord in third position. Also, notice the change of fingering on the first two strings.

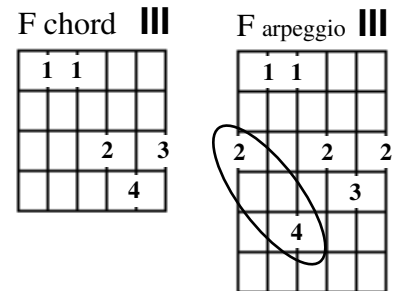

### Add Tones To The C Form F Chord

Add the little-finger notes shown in the ovals on the sixth and first strings.

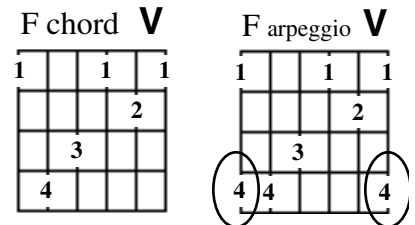

### Add Tones To The C Form F Chord

Add the little-finger note shown in the ovas on the fifth string.

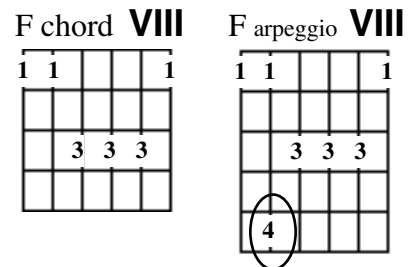

### Add Tones To The G` Form F Chord

Add the little-finger note shown in the ovas on the second string.

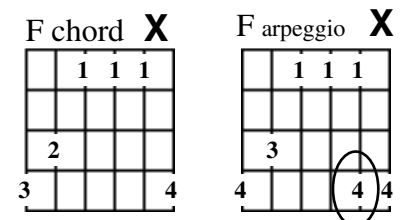

### Play Each Arpeggio In Order Of Pitch

Here is the F major arpeggio in first position, shown in order of ascending pitch. By playing the diagrams from left to right below, you are playing the arpeggio tones in order from lowest to highest.

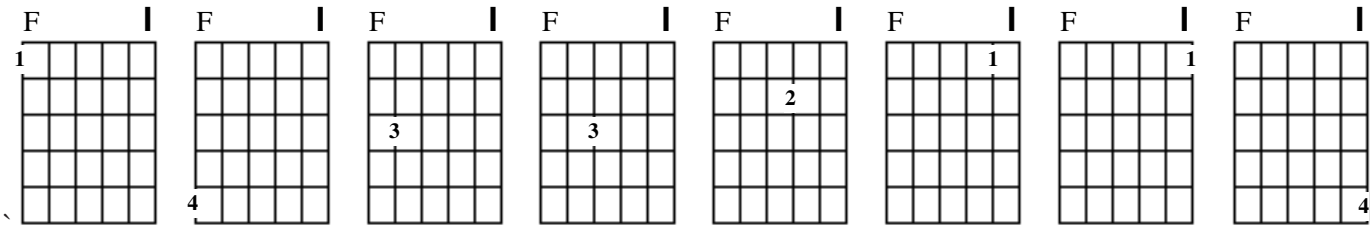

### Play The Five F Major Arpeggios In Order

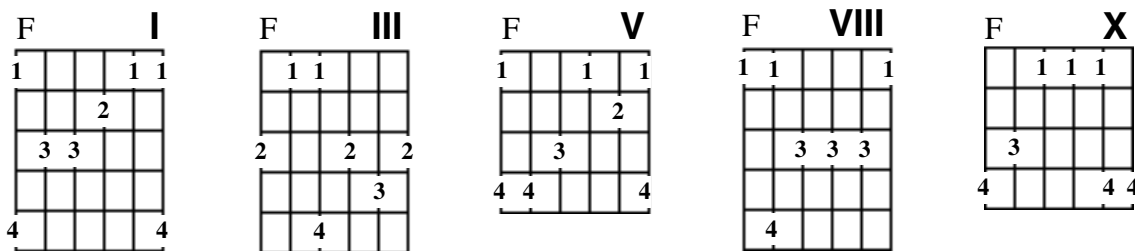

## MEMORIZE C MAJOR CHORDS IN FIVE OCTAVE SHAPES

As was done earlier for F chords, these C chords are compared to the open string chords after which they are formed.

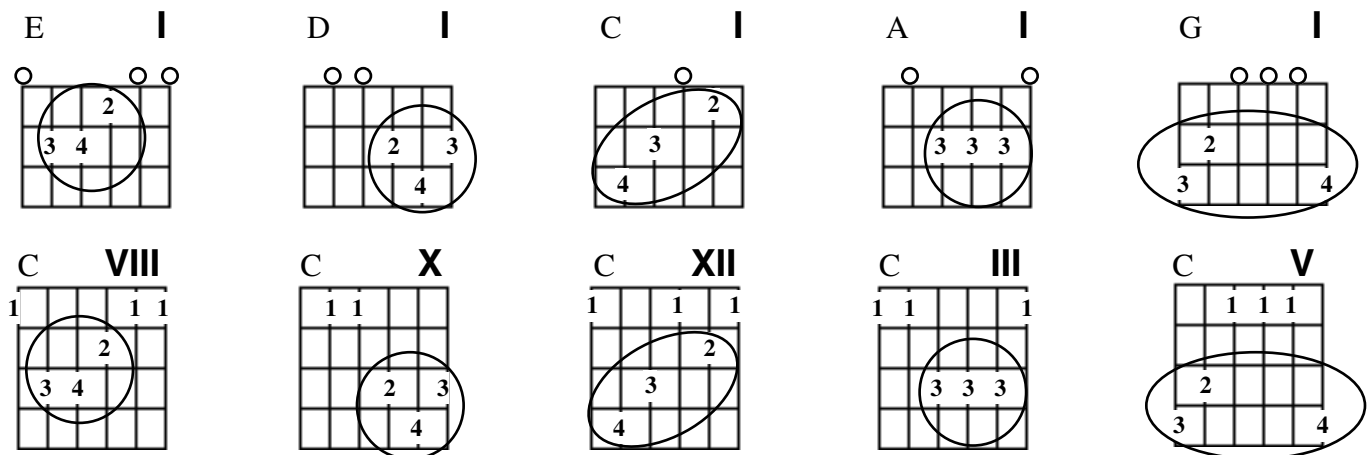

## MEMORIZE C MAJOR ARPEGGIOS IN FIVE OCTAVE SHAPES

Notice C major in III position could also be played in XV position.

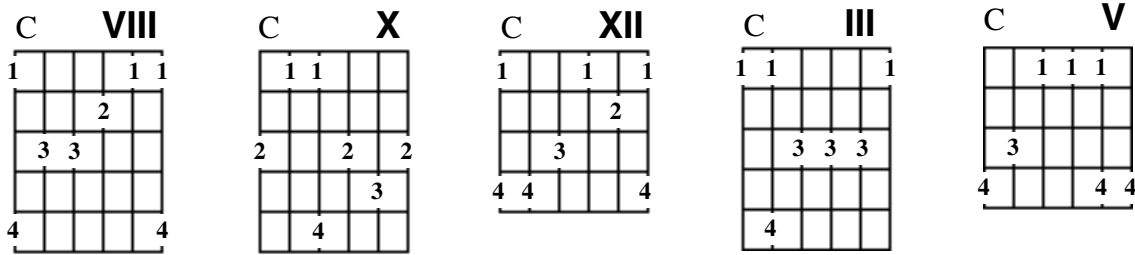

## A SUMMARY OF THE ARPEGGIOS IN F AND C MAJOR

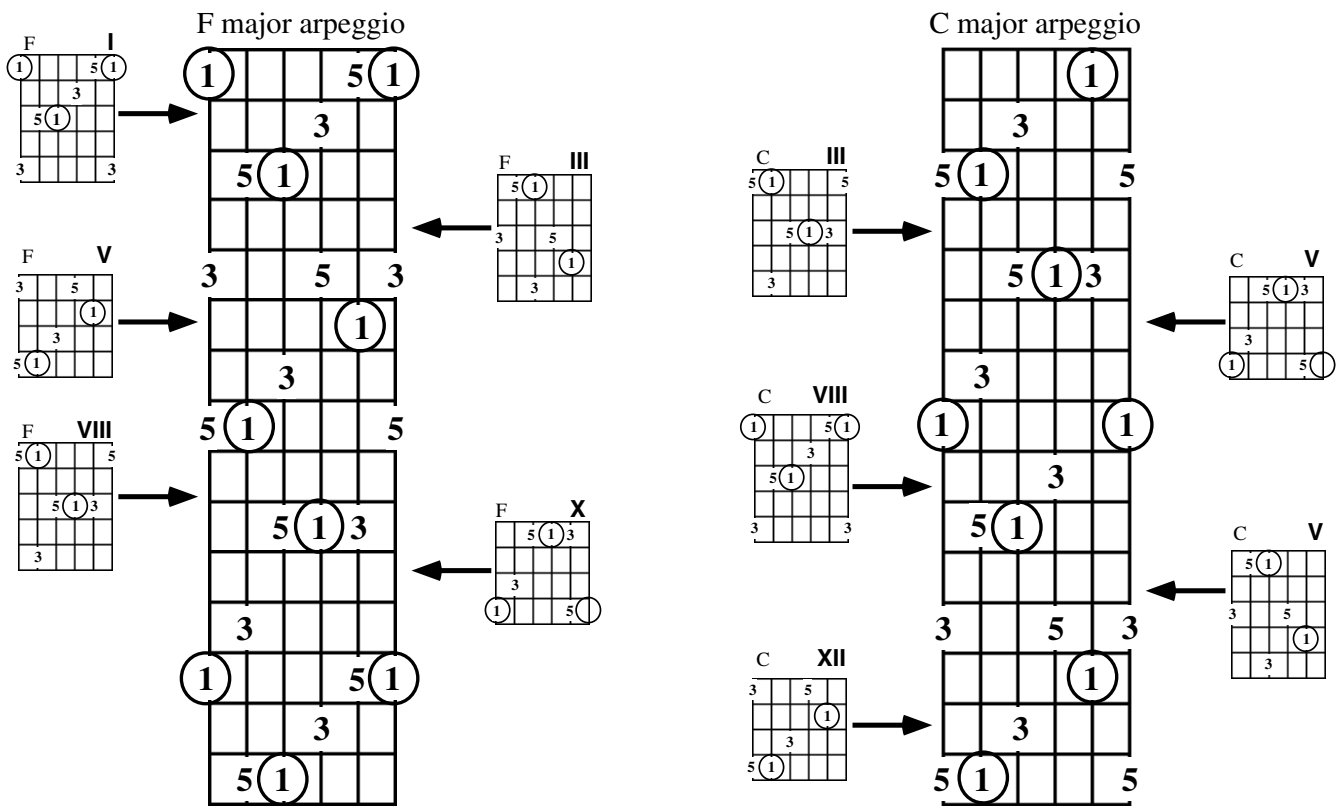

# Choose A Fretboard Area

## DETERMINE THE CHORD ROOT

If you are constructing arpeggios for a particular chord progression, you can determine each root from the beginning of its chord name.

If you don't know the name of a chord for which you want to form and arpeggio, be careful about making assumptions. The lowest tone of the chord is not necessarily the chord root. You should be certain which note of the chord is the root before proceeding. The root is the note after which the chord is named, as defined in Chapter 6. You will learn how to identify an unknown chord root in Chapter 15.

## CHOOSE A LOCATION FOR THE ROOT

Once you determine the name of the chord root, choose a location for it on the guitar fretboard. The best locations are on the sixth, fifth or fourth strings where the root is in its lowest octave. Choose the note "C" on the sixth string, for example.

## Consider Which Finger Will Fret The Root

You may need to complete a few different arpeggios before finding the most practical one. Most arpeggios contain the notes of a major or minor chord (1, 3, 5 or 1,  $\flat$ 3, 5). If you already know a major or minor arpeggio that occurs on the root you have determined, use the same finger. Here are three options for the sixth string, eighth fret "C" note.

fingering options for C note

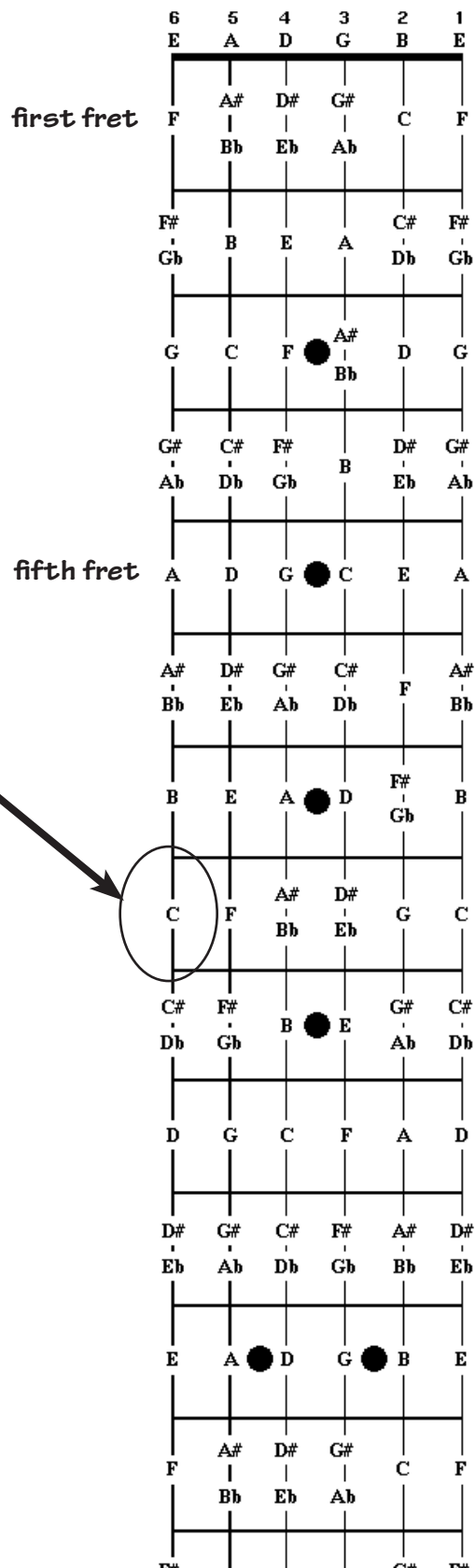
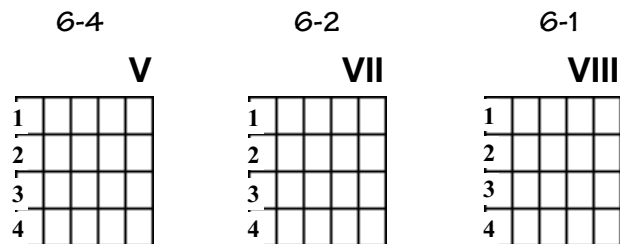



## DEFINE THE ROOT ID

### Review Root ID

Review the root ID system in Chapter 8 to see the locations of the twelve root locations.

Guitar is pattern-based, more than note-based. It is important to memorize note names on the guitar. You will gain quicker access to the patterns of note names used in guitar parts by studying fretboard theory. Arpeggio fingerings can be categorized according to the string and finger used to fret the root in its lowest octave. The root ID provides these categories. Here are a number of arpeggios which share the same root ID:

(left to right)  
each arpeggio lowers a tone by one fret

<p>Fma7 <b>VII</b></p>	<p>F7 <b>VII</b></p>	<p>Fm7 <b>VII</b></p>	<p>Fm7b5 <b>VIII</b></p>	<p>F dim.7 <b>VII</b></p>
------------------------	----------------------	-----------------------	--------------------------	---------------------------

### Consider The Root ID Options

Here are three root ID options for the sixth string, "C" chord root:

<p>root ID 6-4</p> <p><b>V</b></p>	<p>root ID 6-2</p> <p><b>VII</b></p>	<p>root ID 6-1</p> <p><b>VIII</b></p>
--	--	---

## DEFINE THE SVP (STRICT VERTICAL POSITION)

Each of the options for sixth string, "C" chor root define a different strict vertical position.

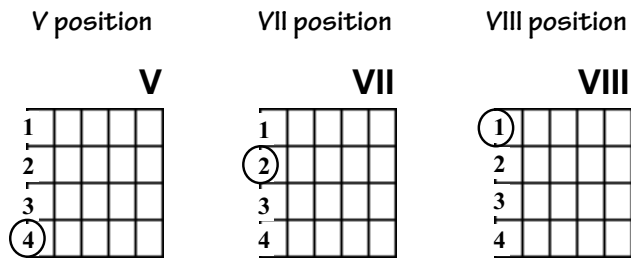

## Construct A Major Scale

If you don't remember how to construct your own major scale, review Chapter 4. The major scale should be constructed with the same finger on the chord root as in the major scale.

### Begin Constructing Arpeggios Based On Seven In-Position Major Scale Fingerings

Here are the seven in-position major scale fingerings for C major:

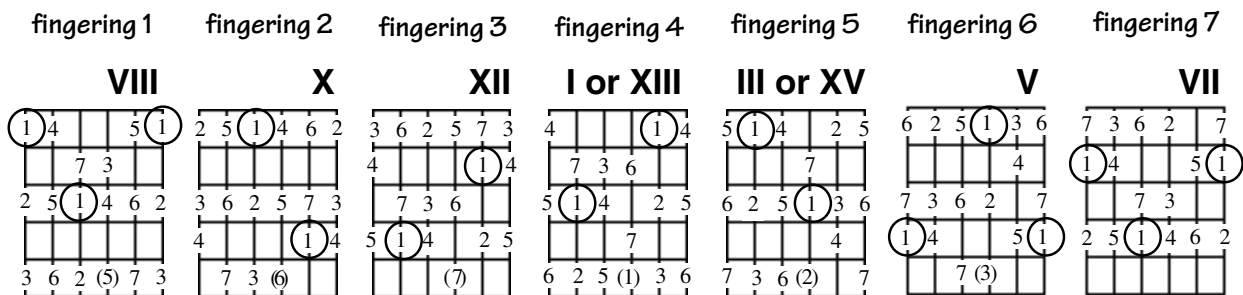

### Consider Major Scale Fingering Options Which Include "C" On The Sixth String

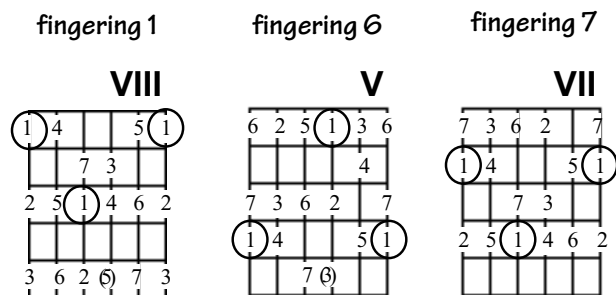

# Access The Chord Formula

## Review

If you don't remember the formula for a chord, look it up in Chapter 6. You may want to review Chapter 6, in any case.

## Formulas For Examples Using Sixth String, Eighth Fret "C"

Here are examples for five chord types: major, minor, major seventh, dominant seventh and minor seventh. The formulas are shown below.

<u>chord type</u>	<u>chord name in C</u>	<u>formula (tones relative to a C major scale)</u>
major	C	1 3 5
minor	Cm	1 b3 5
major seventh	Cma7	1 3 5 7
dominant seventh	C7	1 3 5 b7
minor seventh	Cm7	1 b3 5 b7

## Identify All Chord Tones

After conceiving a major scale fingering which has its tone center on the note intended for the chord root, use the chord formula to find every chord tone in relation to the major scale. It is usually best to go through the scale in ascending order of pitch. Choose the scale tones or altered scale tones (b3, #4, etc.).

## Fretting Altered Tones On Adjacent Strings

If an altered tone is out of reach on a particular string, it can probably be reached on an adjacent string. This requires knowledge of fingering half steps, which was covered in Chapter 3.

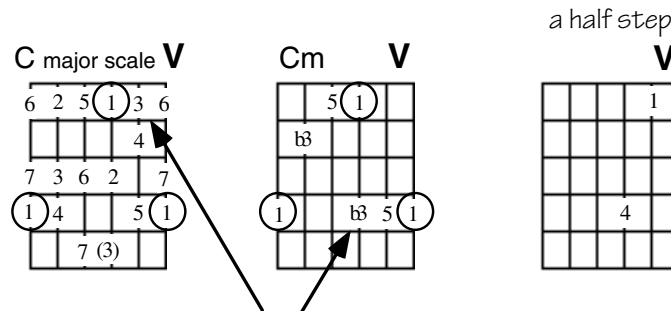

Scale tone "3" in the C major scale (second string) was lowered to "b3" for the Cm chord, fingering a half step lower on the third string.

## Building The Arpeggio Full-Range

To have a complete awareness of the possibilities of chord tones in a particular fingering area, you need to include the full range of the chord tones. If there are chord tones below the root in pitch, include them. Once you learn where the chord tones are, you may want to exclude some of the notes to play the arpeggio from root to root.

Examples are shown below for C, Cm, Cma7, C7 and Cm7 arpeggios with the root ID's 6-1, 6-2 and 6-4. In each of the examples, the arpeggios were constructed full-range. Each arpeggio was based on the major scale fingering shown at the far left of the row. Fingerings are shown for the major scale and arpeggios with scale tone numbers and with finger numbers. For each scale or chord, the scale tone numbers are shown in a diagram above and the finger numbers are shown in a diagram below.

### Examples Using Root ID 6-1

Scale Tone Numbers					
fingering 1	major	minor	major 7	dominant 7	minor 7
C major scale <b>VIII</b>	C <b>VIII</b>	Cm <b>VIII</b>	Cma7 <b>VIII</b>	C7 <b>VIII</b>	Cm7 <b>VIII</b>
Finger Numbers					
C major scale <b>VIII</b>	C <b>VIII</b>	Cm <b>VIII</b>	Cma7 <b>VIII</b>	C7 <b>VIII</b>	Cm7 <b>VIII</b>

Examples Using Root ID 6-2

**Scale Tone Numbers**

<p><b>fingerings 6</b></p> <p>C major scale <b>V</b></p>	<p><b>major</b></p> <p>C <b>V</b></p>	<p><b>minor</b></p> <p>Cm <b>V</b></p>	<p><b>major 7</b></p> <p>Cma7 <b>V</b></p>	<p><b>dominant 7</b></p> <p>C7 <b>V</b></p>	<p><b>minor 7</b></p> <p>Cm7 <b>V</b></p>
--	---------------------------------------	--	--	---	---

**Finger Numbers**

<p>C major scale <b>V</b></p>	<p>C <b>V</b></p>	<p>Cm <b>V</b></p>	<p>Cma7 <b>V</b></p>	<p>C7 <b>V</b></p>	<p>Cm7 <b>V</b></p>
-------------------------------	-------------------	--------------------	----------------------	--------------------	---------------------

Examples Using Root ID 6-4

Notice that the fingerings for the C, Cm and Cm7 arpeggios altered the position used for the major scale for ease of fingering.

**Scale Tone Numbers**

<p><b>fingerings 7</b></p> <p>C major scale <b>VII</b></p>	<p><b>major</b></p> <p>C <b>VI</b></p>	<p><b>minor</b></p> <p>Cm <b>VI</b></p>	<p><b>major 7</b></p> <p>Cma7 <b>VII</b></p>	<p><b>dominant 7</b></p> <p>C7 <b>VI</b></p>	<p><b>minor 7</b></p> <p>Cm7 <b>VI</b></p>
--	--	---	--	--	--

**Finger Numbers**

<p><b>fingerings 7</b></p> <p>C major scale <b>VII</b></p>	<p><b>major</b></p> <p>C <b>VII</b></p>	<p><b>minor</b></p> <p>Cm <b>VI</b></p>	<p><b>major 7</b></p> <p>Cma7 <b>VII</b></p>	<p><b>dominant 7</b></p> <p>C7 <b>VI</b></p>	<p><b>minor 7</b></p> <p>Cm7 <b>VI</b></p>
--	---	---	--	--	--

# Major Arpeggios In All Twelve Positions

Now we'll expand your capabilities of constructing arpeggios through knowledge of in-position fingerings in all twelve positions.

## REFERENCE MAJOR SCALE FINGERINGS

### All Twelve In-Position C Major Scale Fingerings

Here are all twelve in-position major scale fingerings for C major:

		IV position reaching to the third fret		VI position reaching to the fifth fret	
<b>I</b>	<b>III</b>	<b>III</b>	<b>V</b>	<b>V</b>	<b>VII</b>
scale tones	scale tones	scale tones	scale tones	scale tones	scale tones
fingers	fingers	fingers	fingers	fingers	fingers
		IX position reaching to the eighth fret		XI position reaching to the tenth fret	
<b>VIII</b>	<b>VIII</b>	<b>X</b>	<b>X</b>	<b>XII</b>	<b>XII</b>
scale tones	scale tones	scale tones	scale tones	scale tones	scale tones
fingers	fingers	fingers	fingers	fingers	fingers

## EXTRACTING MAJOR ARPEGGIOS FROM MAJOR SCALE FINGERINGS

By playing only tones “1, 3 and 5” of each major scale fingering, you create all possible major arpeggios. You can then learn to add to and modify those arpeggios to create arpeggios for all other chords.

### All Twelve In-Position C Major Arpeggio Fingerings

All twelve in-position major arpeggio fingerings for C major are shown below. Notice that in many cases, there are optional ways to finger the same note. All twelve in-position major scale fingerings were shown earlier.

		IV position reaching to the third fret		VI position reaching to the fifth fret	
<b>II</b>	<b>III</b>	<b>III</b>	<b>V</b>	<b>V</b>	<b>VII</b>
scale tones	scale tones	scale tones	scale tones	scale tones	scale tones
fingers	fingers	fingers	fingers	fingers	fingers
		IX position reaching to the eighth fret		XI position reaching to the tenth fret	
<b>VIII</b>	<b>VIII</b>	<b>X</b>	<b>X</b>	<b>XII</b>	<b>XII</b>
scale tones	scale tones	scale tones	scale tones	scale tones	scale tones
fingers	fingers	fingers	fingers	fingers	fingers

## CONCEIVING FULL-FRETBOARD MAJOR AND MINOR CHORD TONES

All major chord tones can be represented with three arpeggios.

### Major Chord Tones In Three Arpeggios

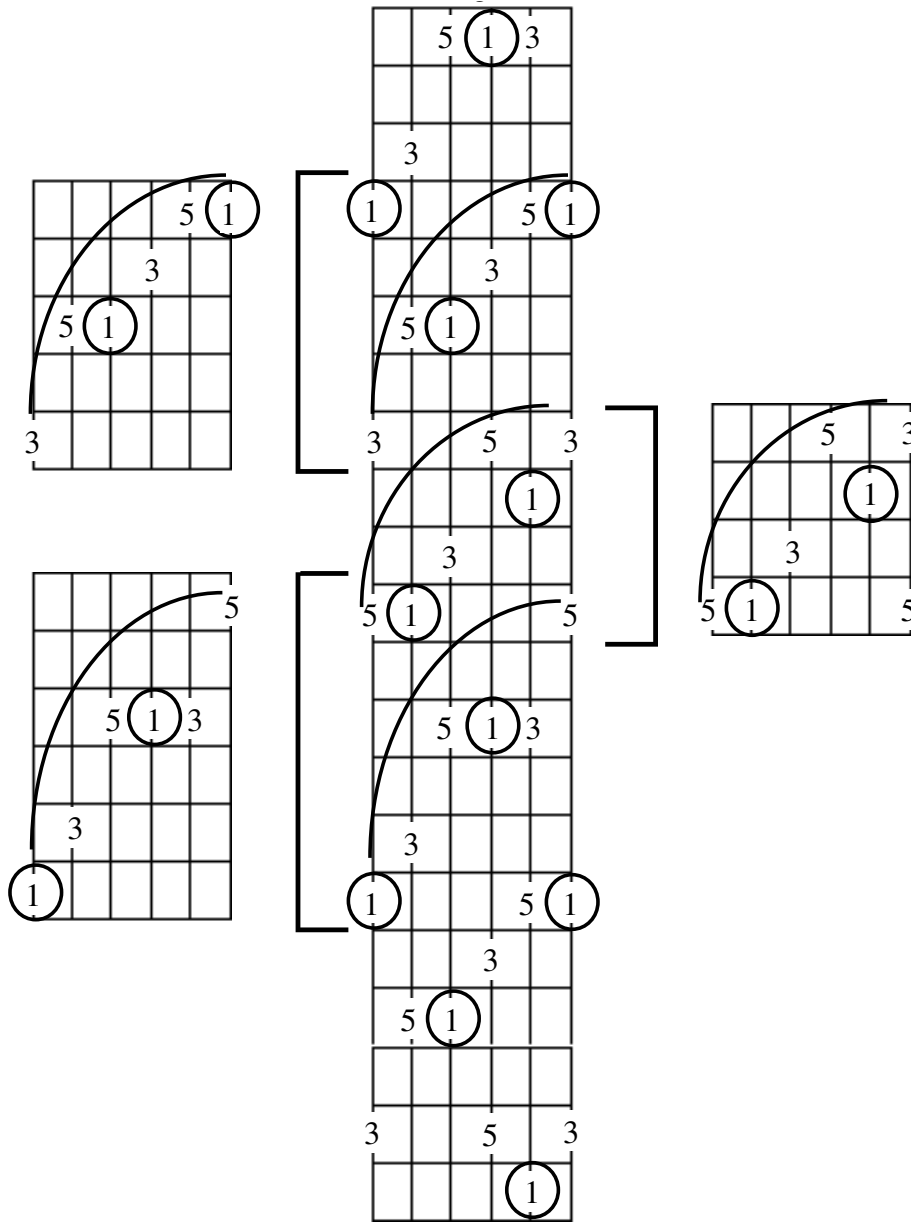

### PRACTICE MAJOR SCALE AND MAJOR ARPEGGIO EXERCISES IN APPENDIX I

These exercises summarize the most practical major arpeggios when they are combined in melodic phrases with major scale fingerings in the same key (C major arpeggio with C major scale, for example).



# Deriving All Arpeggios From Major

## MODIFYING AND SUPPLEMENTING MAJOR ARPEGGIOS

By modifying or adding to major arpeggio fingerings you can create arpeggio fingerings for all other chords. From those arpeggios, you can create all chord fingerings.

The diagram below represents a single string. The vertical lines represent frets. The interval from the root up in pitch to the third of a major chord is two whole steps (four frets). From the third up to the fifth is one and a half steps (three frets). From the fifth up to the root (in the next octave) is two and one half steps. Any note you may need for a chord is within a whole step (two frets) of a major chord tone.

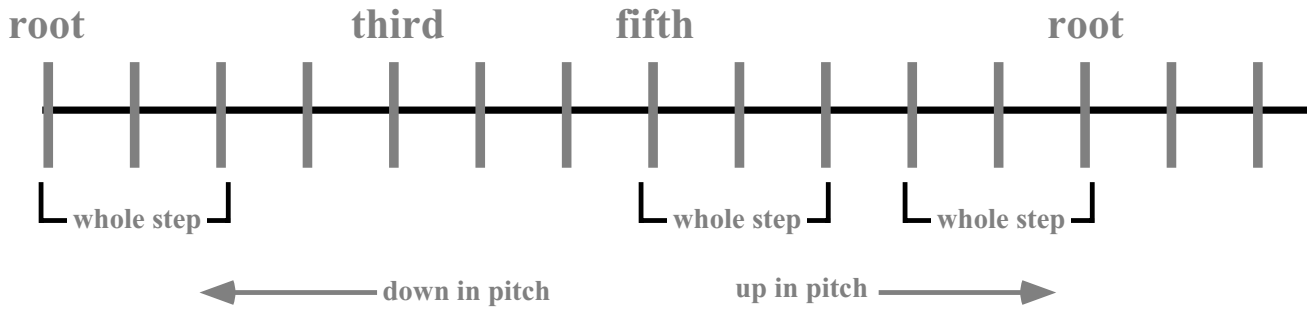

### Using Major Chord Tones As Reference Notes On The Same String

If a chord requires a note which is reachable on the same string where the reference major chord tone occurred, calculating its location is straightforward. I have provided some examples below where each of the desired chord tones were accessible on the same string as the major chord tone they were referenced to. A major chord contains the numbered tones "1, 3, and 5" of the major scale on its root. Each of these examples involves flattening the third, changing it to "b3", where the flatted third is easily reachable on the same string.

reference tones	"3" lowered to "b3"	reference tones	"3" lowered to "b3"	reference tones	"3" lowered to "b3"																																																																																																																																																						
A major <b>V</b>	A minor <b>V</b>	D major <b>V</b>	D minor <b>V</b>	F major <b>V</b>	F minor <b>IV</b>																																																																																																																																																						
<table border="1" style="border-collapse: collapse; text-align: center;"> <tr><td>1</td><td></td><td></td><td>5</td><td>1</td></tr> <tr><td></td><td></td><td>3</td><td></td><td></td></tr> <tr><td>5</td><td>1</td><td></td><td></td><td></td></tr> <tr><td></td><td></td><td></td><td></td><td></td></tr> <tr><td>3</td><td></td><td></td><td></td><td>3</td></tr> </table>	1			5	1			3			5	1									3				3	<table border="1" style="border-collapse: collapse; text-align: center;"> <tr><td>1</td><td></td><td>b3</td><td>5</td><td>1</td></tr> <tr><td></td><td></td><td></td><td></td><td></td></tr> <tr><td>5</td><td>1</td><td></td><td></td><td></td></tr> <tr><td></td><td></td><td></td><td></td><td></td></tr> <tr><td>b3</td><td></td><td></td><td></td><td>b3</td></tr> </table>	1		b3	5	1						5	1									b3				b3	<table border="1" style="border-collapse: collapse; text-align: center;"> <tr><td>1</td><td></td><td></td><td>5</td><td></td></tr> <tr><td></td><td></td><td></td><td></td><td></td></tr> <tr><td>5</td><td>1</td><td>3</td><td></td><td></td></tr> <tr><td></td><td></td><td></td><td></td><td></td></tr> <tr><td>3</td><td></td><td></td><td></td><td></td></tr> </table>	1			5							5	1	3								3					<table border="1" style="border-collapse: collapse; text-align: center;"> <tr><td>1</td><td></td><td></td><td>5</td><td></td></tr> <tr><td></td><td></td><td></td><td></td><td></td></tr> <tr><td>5</td><td>1</td><td></td><td></td><td></td></tr> <tr><td></td><td></td><td></td><td></td><td></td></tr> <tr><td>b3</td><td></td><td></td><td></td><td></td></tr> </table>	1			5							5	1									b3					<table border="1" style="border-collapse: collapse; text-align: center;"> <tr><td></td><td></td><td>5</td><td>3</td><td></td></tr> <tr><td></td><td></td><td></td><td></td><td></td></tr> <tr><td></td><td></td><td>1</td><td></td><td></td></tr> <tr><td>3</td><td></td><td></td><td></td><td></td></tr> <tr><td>1</td><td></td><td></td><td>5</td><td></td></tr> </table>			5	3									1			3					1			5		<table border="1" style="border-collapse: collapse; text-align: center;"> <tr><td></td><td></td><td></td><td></td><td>b3</td></tr> <tr><td></td><td></td><td></td><td></td><td></td></tr> <tr><td></td><td></td><td>5</td><td></td><td></td></tr> <tr><td></td><td></td><td>b3</td><td>1</td><td></td></tr> <tr><td>1</td><td></td><td></td><td></td><td>5</td></tr> </table>					b3								5					b3	1		1				5
1			5	1																																																																																																																																																							
		3																																																																																																																																																									
5	1																																																																																																																																																										
3				3																																																																																																																																																							
1		b3	5	1																																																																																																																																																							
5	1																																																																																																																																																										
b3				b3																																																																																																																																																							
1			5																																																																																																																																																								
5	1	3																																																																																																																																																									
3																																																																																																																																																											
1			5																																																																																																																																																								
5	1																																																																																																																																																										
b3																																																																																																																																																											
		5	3																																																																																																																																																								
		1																																																																																																																																																									
3																																																																																																																																																											
1			5																																																																																																																																																								
				b3																																																																																																																																																							
		5																																																																																																																																																									
		b3	1																																																																																																																																																								
1				5																																																																																																																																																							

### Using Major Chord Tones As Reference Notes On Adjacent Strings

In these next examples (below), the thirds are flatted, making minor arpeggios (as was done above). Some of these thirds are more easily reached on an adjacent string. Fretting four frets higher on the next larger string descends a half step, except notes on the second string descend a half step by fretting three frets higher on the next larger string.

reference  
tones  
A major **II**

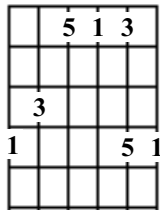

"3" lowered  
to "b3"  
A minor **I**

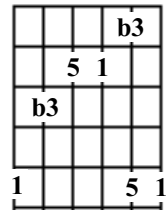

"3" lowered  
to "b3"  
A minor **II**

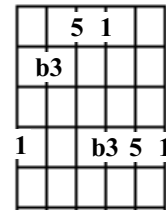

reference  
tones  
D major **IV**

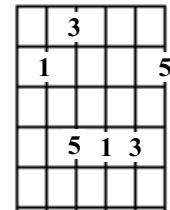

"3" lowered  
to "b3"  
D minor **III**

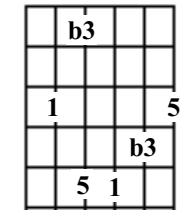

"3" lowered  
to "b3"  
D minor **V**

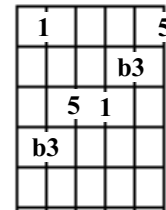

### BRIDGING THE OCTAVE SHAPES

Once you learn one full-range major and minor arpeggio in each of the five octave shapes (shown near the beginning of this chapter), you should begin conceiving pairs of adjacent octave shape areas. An effective way to do this is by summarizing the available chord tones in the adjoined area with a few chord fingerings.

### Major Chords Summarizing The E Form and D Form Areas

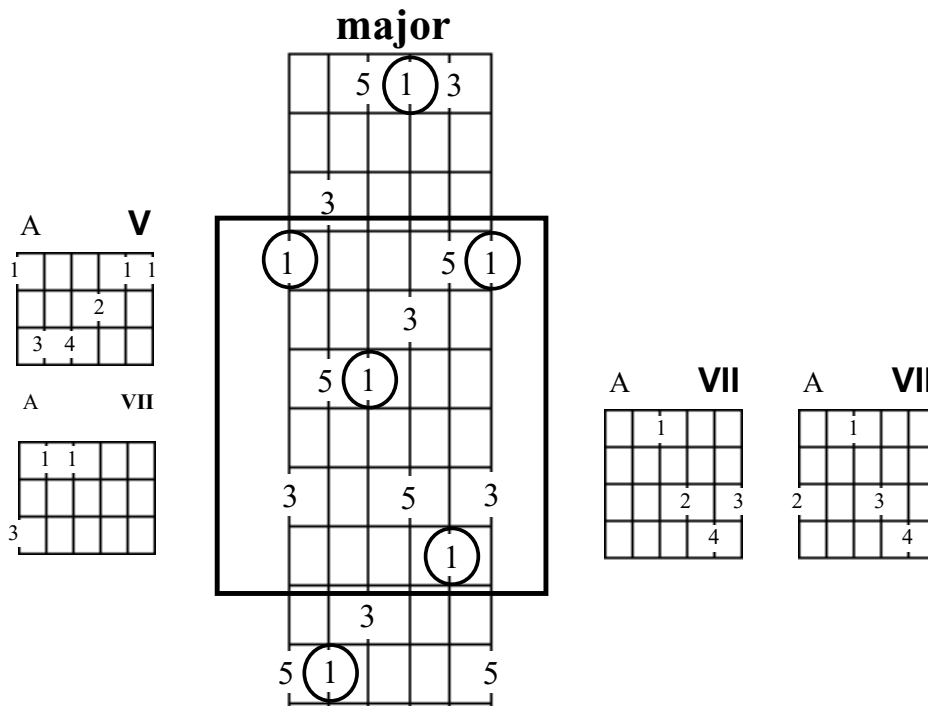

## Minor Chords Summarizing The E Form and D Form Areas

**minor**

Am **V**

Am **VII**

Am **VII**

Am **VII**

## Summary Chord Fingerings

To conceive a chord fingering you should first review a full-range arpeggio for it in the fretboard area where you want the chord. That will bring to mind every possible chord tone for the area. It is most effective to also bring some chord fingerings to mind that summarize the arpeggio tones.

## Major Chord Fingerings That Summarize Full-Fretboard Major Chord Tones

A <b>V</b>	A <b>VI</b>	A <b>VII</b>	A <b>VII</b>	A <b>VII</b>	A <b>IX</b>	A <b>IX</b>
A <b>IX</b>	A <b>XI</b>	A <b>XII</b>	A <b>II</b>	A <b>II</b>	A <b>II</b>	

### Minor Chord Fingerings That Summarize Full-Fretboard Major Chord Tones

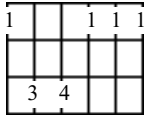
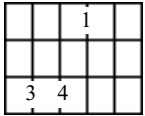
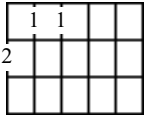
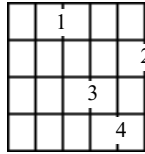
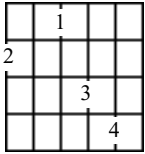
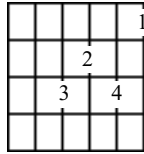
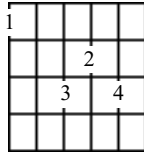
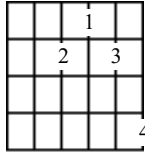
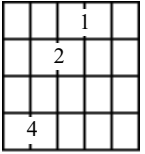
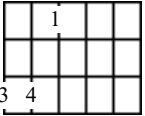
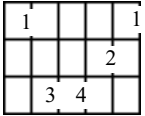
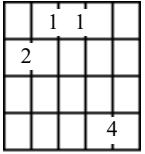
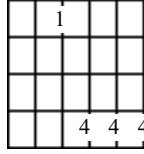
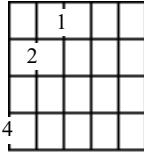
Am <b>V</b>	Am <b>V</b>	Am <b>VII</b>	Am <b>VII</b>	Am <b>VII</b>	Am <b>VIII</b>	Am <b>VIII</b>
						
Am <b>IX</b>	Am <b>IX</b>	Am <b>X</b>	Am <b>XII</b>	Am <b>II</b>	Am <b>II</b>	Am <b>II</b>
						

### Arpeggios And Summary Chord Fingerings For Other Chords

A thorough preparation for chord construction includes a knowledge of many four-note chords in (1) arpeggios in all twelve strict vertical positions and (2) summary chord fingerings for those arpeggios. The four note chords should include: major 7, 7 (dominant seventh), m7, m7b5, diminished 7 (m6b5), 6 and m6.

**Appendix B includes summary chords for five seventh chord types**

# Spelling Major Scales

- **Spelling Major Scales Defined**
- **Preparing To Determine Chord Roots**
- **Key Signatures**
- **The Cycle Of Fifths**
- **Q & A On Key Signatures**
- **Using Key Signatures To Spell Major Scales**

## “Spelling” Major Scales Defined

“Spelling” major scales is naming the letter names of the notes in the scale. Here are a few examples:

major scale	spelling
C	C D E F G A B C
F	F G A B $\flat$ C D E F
G	G A B C D E F $\sharp$ G

## Preparing To Determine Chord Roots

To be able to determine chord roots in the next chapter, you’ll need to be able to name the notes in any major scale. The fifteen major scales are shown below.

### FIFTEEN MAJOR SCALES

*(three of the keys have two versions)*

C major: C D E F G A B C

G major: G A B C D E F $\sharp$  G

D major: D E F $\sharp$  G A B C $\sharp$  D

A major: A B C $\sharp$  D E F $\sharp$  G $\sharp$  A

E major: E F $\sharp$  G $\sharp$  A B C $\sharp$  D $\sharp$  E

B major: B C $\sharp$  D $\sharp$  E F $\sharp$  G $\sharp$  A $\sharp$  B

F $\sharp$  major: F $\sharp$  G $\sharp$  A $\sharp$  B C $\sharp$  D $\sharp$  E $\sharp$  F $\sharp$

C $\sharp$  major: C $\sharp$  D $\sharp$  E $\sharp$  F $\sharp$  G $\sharp$  A $\sharp$  B $\sharp$  C $\sharp$

F major: F G A B $\flat$  C D E F

B $\flat$  major: B $\flat$  C D E $\flat$  F G A $\flat$  B $\flat$

E $\flat$  major: E $\flat$  F G A $\flat$  B $\flat$  C D E $\flat$

A $\flat$  major: A $\flat$  B $\flat$  C D $\flat$  E $\flat$  F G A $\flat$

D $\flat$  major: D $\flat$  E $\flat$  F G $\flat$  A $\flat$  B $\flat$  C D $\flat$

G $\flat$  major: G $\flat$  A $\flat$  B $\flat$  C $\flat$  D $\flat$  E $\flat$  F G $\flat$

C $\flat$  major: C $\flat$  D $\flat$  E $\flat$  F $\flat$  G $\flat$  A $\flat$  B $\flat$  C $\flat$

### ENHARMONIC KEYS

Enharmonic notes have different names for the same pitch. C $\flat$  and B are the same note. F $\sharp$  and G $\flat$  are the same note. Notice that major scales in three of the keys above have dual names.

Enharmonic keys have notes with the same pitches, but different note names. There are twelve different major scales, but three of them have two possible names:

1. F $\sharp$  and G $\flat$  major both have the same pitches, with different names.
2. C $\flat$  and B major scales both have the same pitches, with different names
3. C $\sharp$  and D $\flat$  major scales both have the same pitches, with different names

# Key Signatures

## KEY SIGNATURES SIMPLIFY MUSIC NOTATION

When a piece of music uses predominantly one major scale, it is simpler to indicate any sharped or flatted notes at the beginning of each section, rather than before every altered note. This system is called key signatures. All fifteen major scales are shown again below, with key signatures. There are patterns to the system of key signatures, which you will learn in the next few pages.

The image displays 15 major scales in treble clef, 4/4 time, each with its key signature and a list of notes below it. The scales are arranged in four rows:

- Row 1:** C major (C D E F G A B C), G major (G A B C D E F# G), D major (D E F# G A B C# D), A major (A B C# D E F# G# A)
- Row 2:** E major (E F# G# A B C# D# E), B major (B C# D# E F# G# A# B), F# major (F# G# A# B C# D# E# F#), C# major (C# D# E# F# G# A# B# C#)
- Row 3:** F major (F G A Bb C D E F), Bb major (Bb C D Eb F G Ab Eb), Eb major (Eb F G Ab Bb C D Eb), Ab major (Ab Bb C Db Eb F G Ab)
- Row 4:** Db major (Db Eb F Gb Ab Bb C Db), Gb major (Gb Ab Bb Cb Db Eb F Gb), Cb major (Cb Db Eb Fb Gb Ab Bb Cb)

## TWELVE RULES FOR KEY SIGNATURES:

1. Each key signature indicates the notes of one particular major scale.
2. A key signature applies throughout a piece of music or until another key signature is shown, at which point the new key signature applies (until another key signature may be shown).
3. Every major scale uses the same seven letters: A B C D E F G. These seven letters form an alphabetical cycle (below). Each major scale starts on the letter after which it is named and follows the alphabetical cycle around to the same letter

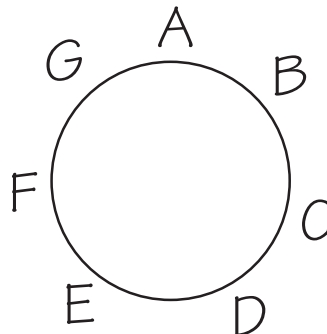

4. Each major scale has one or more notes sharped or flatted except C major, which has no sharps or flats.
5. Each key uses each letter once only (F and F $\sharp$ , B and B $\flat$  are never used in the same major scale). Major scales never combine sharps and flats: they always use one or the other.
6. F major's key signature has one flat: B $\flat$ .
7. There is a series of "sharp" keys which have one or more sharps in their key signature:
  - If a key has one sharp ( $\sharp$ ), the sharp is .....F $\sharp$ .
  - If the key has two sharps, the sharps are .....F $\sharp$  C $\sharp$ .
  - If the key has three sharps, the sharps are .....F $\sharp$  C $\sharp$  G $\sharp$ .
  - If the key has four sharps, the sharps are.....F $\sharp$  C $\sharp$  G $\sharp$  D $\sharp$ .
  - If the key has five sharps, the sharps are .....F $\sharp$  C $\sharp$  G $\sharp$  D $\sharp$  A $\sharp$ .
  - If the key has six sharps, the sharps are.....F $\sharp$  C $\sharp$  G $\sharp$  D $\sharp$  A $\sharp$  E $\sharp$ .
  - If the key has seven sharps, the sharps are .....F $\sharp$  C $\sharp$  G $\sharp$  D $\sharp$  A $\sharp$  E $\sharp$  B $\sharp$ .

If sharp keys are placed in order with one through seven sharps, they are in order of perfect fifths: F $\sharp$  C $\sharp$  G $\sharp$  D $\sharp$  A $\sharp$  E $\sharp$  B $\sharp$ . So, sharps accumulate in the order F C G D A E B:

**Fat Cats Get Down At Ed's Barbeque**

8. There is a series of six flat keys which have two or more flats in their key signatures:
  - If a key has two flats, the flats are.....B $\flat$  E $\flat$ .
  - If a key has three flats, the flats are.....B $\flat$  E $\flat$  A $\flat$ .
  - If a key has four flats, the flats are.....B $\flat$  E $\flat$  A $\flat$  D $\flat$ .
  - If a key has five flats, the flats are.....B $\flat$  E $\flat$  A $\flat$  D $\flat$  G $\flat$ .
  - If a key has six flats, the flats are .....B $\flat$  E $\flat$  A $\flat$  D $\flat$  G $\flat$  C $\flat$ .
  - If a key has seven flats, the flats are.....B $\flat$  E $\flat$  A $\flat$  D $\flat$  G $\flat$  C $\flat$  F $\flat$ .

If flat keys are placed in order with 1 through 7 flats in their key signature, they are in order of perfect fourths: B $\flat$  E $\flat$  A $\flat$  D $\flat$  G $\flat$  C $\flat$  F $\flat$ . So, flats accumulate in the order B E A D G C F:

**Bug Eyes Are Darn Good Cat Fish**

or

**use a BEAD to Go Catch Fish**

9. When reading the sharps as they appear in the key signature from left to right, raise the last sharp (on the right) in a key signature a half step to produce the name of the key. If the last sharp in the key signature is F $\sharp$ , raising it a half step would produce "G", so the key is G.



10. When reading the flats as they appear in the key signature from left to right, look at the next-to-last flat. It is the literal name of the key. If the flats in the key signature are B $\flat$  E $\flat$  A $\flat$  D $\flat$ , the name of the key is A $\flat$  major. If the flats in the key signature are B $\flat$  E $\flat$  A $\flat$  D $\flat$  G $\flat$ , the name of the key is D $\flat$  major.
11. All key signatures with flats in their key signature have a flat in their name (such as B $\flat$ ), except F major.
12. B, E, A, D and G major have no sharps in their name, but have sharps in their key signature.

### **A SHORTER LIST OF KEY SIGNATURE RULES:**

1. C major has no sharps nor flats.
2. F major has one flat: B $\flat$ .
3. In key signatures, sharps are written in the order FCGDAEB, flats in the reverse order: BEADGCF. If a key has one sharp, the sharp is F $\sharp$ . If it has two sharps, they are F $\sharp$  and C $\sharp$ . If a key has one flat, the flat is B $\flat$ . If it has two flats, they are B $\flat$  and E $\flat$ .
4. When reading the sharps as they appear in the key signature from left to right, raise the last sharp (on the right) in a key signature a half step to produce the name of the key.
5. When reading the flats as they appear in the key signature from left to right, look at the next-to-last flat. It is the literal name of the key.

# The Cycle Of Fifths

This cycle shows the keys in order of increasing sharps (decreasing flats) clockwise and increasing flats (decreasing sharps) counter-clockwise.

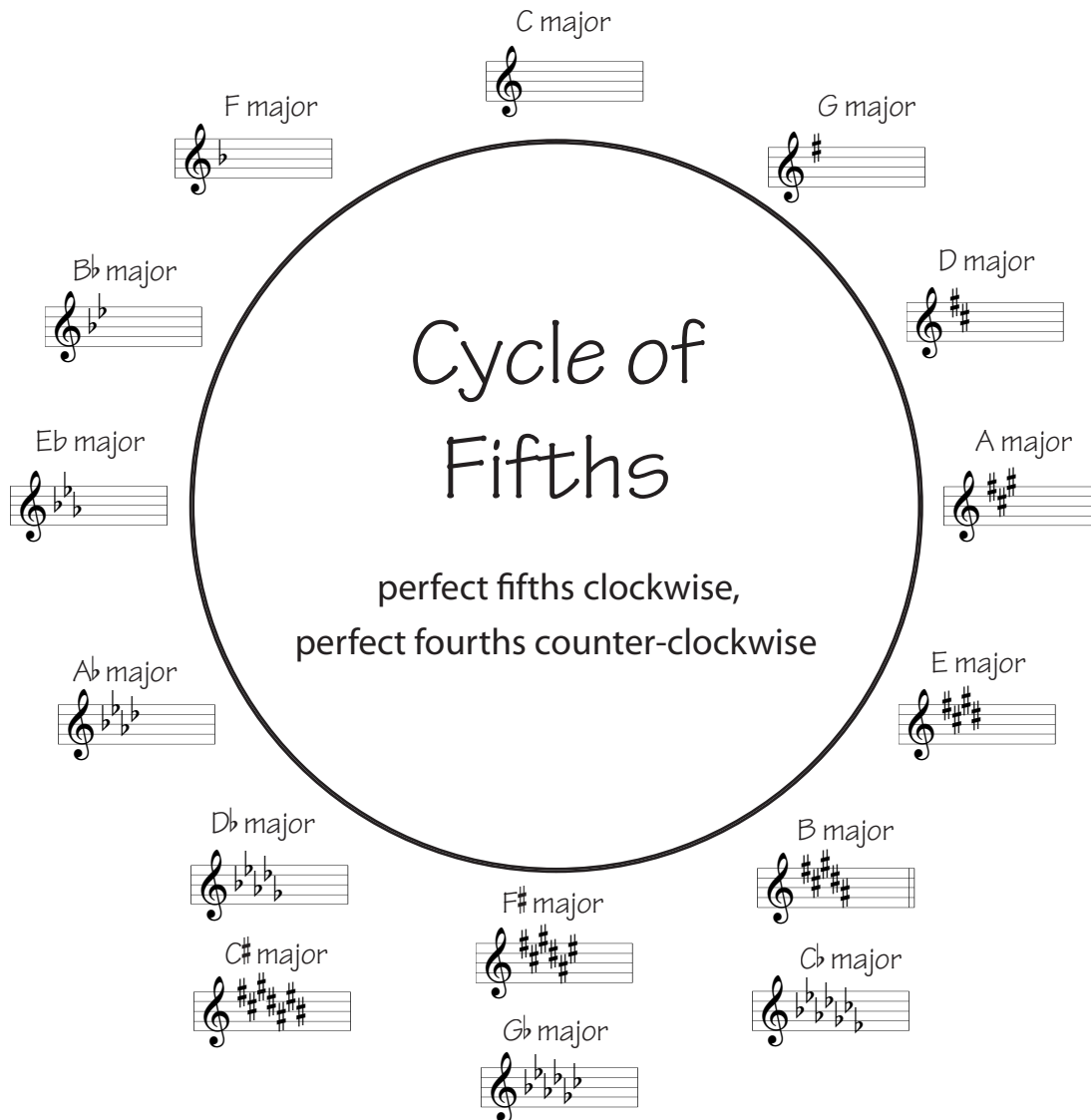

## Q & A On Key signatures

questions (Q) and answers (A)

- Q: What is the key signature for C major? A: no sharps nor flats
- Q: What is the key signature for F major? A: Bb
- Q: What is the order of sharps? A: F C G D A E B
- Q: What is the order of flats? A: B E A D G C F
- Q: If you had two sharps in a key signature, what would they be? A: F# and C#

- Q: If you had two flats in a key signature, what would they be? A: B $\flat$  and E $\flat$
- Q: If you had three sharps in a key signature, what would they be? A: F $\sharp$ , C $\sharp$  and G $\sharp$
- Q: If you had three flats in a key signature, what would they be? A: B $\flat$ , E $\flat$  and A $\flat$
- Q: If you had four sharps in a key signature, what would they be? A: F $\sharp$ , C $\sharp$ , G $\sharp$  and D $\sharp$
- Q: If you had four flats in a key signature, what would they be? A: B $\flat$ , E $\flat$ , A $\flat$ , D $\flat$
- Q: If you had five sharps in a key signature, what would they be? A: F $\sharp$ , C $\sharp$ , G $\sharp$ , D $\sharp$ , A $\sharp$
- Q: If you had five flats in a key signature, what would they be? A: B $\flat$ , E $\flat$ , A $\flat$ , D $\flat$ , G $\flat$
- Q: If you had six sharps in a key signature, what would they be? A: F $\sharp$ , C $\sharp$ , G $\sharp$ , D $\sharp$ , A $\sharp$ , E $\sharp$
- Q: If you had six flats in a key signature, what would they be? A: B $\flat$ , E $\flat$ , A $\flat$ , D $\flat$ , G $\flat$ , C $\flat$
- Q: If you had seven sharps in a key signature, what would they be? A: F $\sharp$ , C $\sharp$ , G $\sharp$ , D $\sharp$ , A $\sharp$ , E $\sharp$ , B $\sharp$
- Q: If you had seven flats in a key signature, what would they be? A: B $\flat$ , E $\flat$ , A $\flat$ , D $\flat$ , G $\flat$ , C $\flat$ , F $\flat$
- Q: What is a natural letter name? A: One that has no flat or sharp
- Q: If a key has a sharp letter name, does it have sharps or flats in its key signature? A: Sharps.
- Q: If a key has a flat letter name, does it have sharps or flats in its key signature? A: Flats.
- Q: If a key signature uses flats, is its name a letter with a flat, sharp or natural? A: With a flat or it is the key of F major (which has B $\flat$  in its key signature).
- Q: If a key signature uses sharps, is its name a letter with a flat, sharp or natural? A: With a natural, except F $\sharp$  major (FCGDAE sharped), C $\sharp$  major (FCGDAEB sharped).
- Q: How do you name a key which has sharps in its key signature. A: Raise the last sharp a halfstep and make sure the letter has increased by one alphabetically as well.
- Q: How do you name a key which has flats in its key signature. A: It is the literal name of the next-to-last flat.

## Using Key Signatures To Spell Major Scales

### Memorize C Major and F major

You must memorize the key signatures for C major and F major. The key signature for C major has no sharps nor flats, so the C major scale is C, D, E, F, G, A, B, C. F major has one flat: B $\flat$ . When you recite the F major scale by alphabetically recalling the musical alphabet from “F” to “F”, flat the B: F, G, A, B $\flat$ , C, D, E, F.

### Using Key Signatures to Recall Flat Keys

If a key has a flat in its name, you must visualize the key signature that would have the name of the key as the next to last flat. B $\flat$  major would require the flats B $\flat$ , E $\flat$ . E $\flat$  major would require B $\flat$ , E $\flat$ , A $\flat$ .

Recite the B $\flat$  major scale by alphabetically recalling the musical alphabet from “B $\flat$ ” to “B $\flat$ ”, and flattening the B and E as you go: B $\flat$ , C, D, E $\flat$ , F G A B $\flat$ .



# Structural Chord Types

- **Chords Are Usually Constructed In Thirds**
- **Memorizing Major Scale With Key Signatures**
- **Chord Types**
- **Determining The Chord Root**

# Chords Are Usually Constructed In Thirds

## TENSION VERSUS RELAXATION

Music involves an interplay between tension and relaxation. Chords provide various degrees of relaxation or release of tension. Melodies weave around the tones of the current chord, generally emphasizing the chord tones and de-emphasizing non-chordal tones. Emphasis can be accomplished by frequent occurrence, sustain, placement on noticeable parts of the measure, or anything else that draws attention to a note.

Harmony is based on the series of every other note in the major scale system. By playing every other note in the major scale, you create a series of tones which create very little tension and are conducive to producing a state of agreement, concord and harmony.

## THE TERTIAN CYCLE

The every-other-note series of tones in the major scale can be called the tertian cycle. *Tertian* is a Greek word implying *made of threes*. From each number in the cycle, counting the number on which you begin, it is three numbers to the next. Think of it as an every-other-number pattern, where after “7” you skip “1” and continue from “2”. After “6” you skip “7” and begin again at “1”.

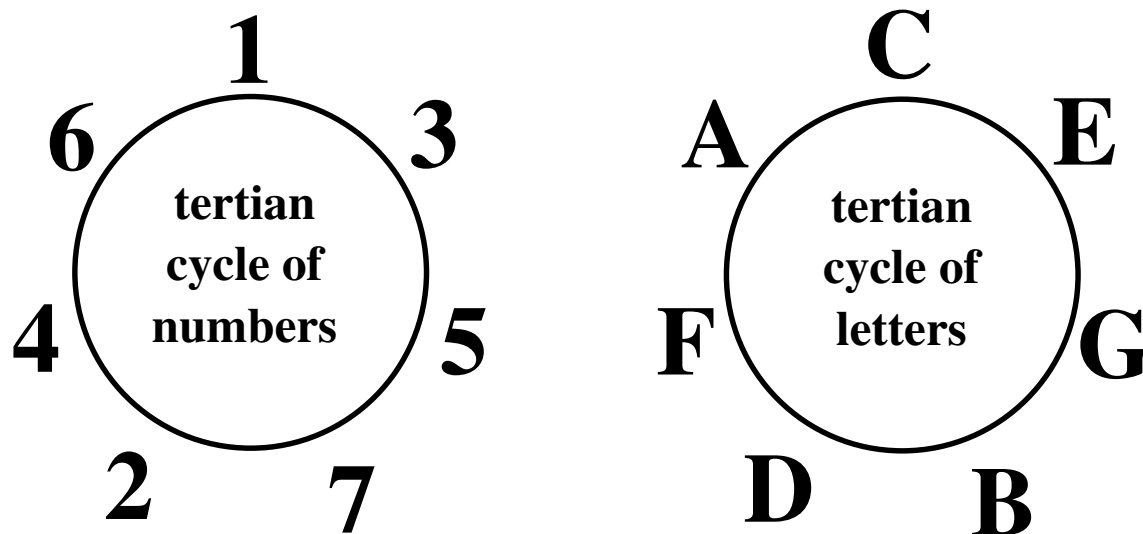

In letters, this cycle represents the pattern of note names on “all lines” or “all spaces” in music notation:

D F A C E G B D F A C E G B D F

E G B D F A C E G B D F A C E G

A “C” major chord consists of the notes “C, E, G”, which are three consecutive letters in the tertian cycle, beginning with “C”. Numerically, the “C” major chord uses tones “1, 3, 5” of a “C” major scale.

### Thirds Are Pairs Of Notes In The Tertian Cycle

Play the C major scale on the fifth string, as shown in the first two measures below. Notice that in the third and fourth measures, the C major scale is repeated on the fifth string, but accompanied by notes on the fourth string. Each tone on the fourth string is a major scale tone third higher than the note it harmonizes on the fifth string, and is one tone higher in the tertian cycle.

C D E F G A B C E F G A B C D E  
C D E F G A B C

T 4/4  
A 4/4  
B 4/4

3 5 7 8 10 12 14 15 2 3 5 7 9 10 12 14

## Triads Are Three Note Groups From The Tertian Cycle

In measures one and two below, the notes on the third string are each a major scale tone third above the corresponding tone on the fourth string. These three note chords are called *tertian triads*.

G A B C D E F G B C D E F G A B  
 E F G A B C D E F G A B C D E F G A B  
 C D E F G A B C D E F G A B C D E F G A B

T  
 A 0 2 4 5 7 9 10 12 0 1 3 5 6 8 10 12  
 B 3 3 5 7 8 9 10 12 3 3 5 7 7 9 10 12 14

## Quadrads (Scale Tone Sevenths) Are Four Note Groups From The Tertian Cycle

In measures three and four above, the notes on the second string are each a major scale tone third above the corresponding tone on the third string. While these four note chords are technically *tertian quadrads*, they are more commonly called *scale tone seventh chords*, which can be confusing.

## The Term *Seventh Chord* Is Used Ambiguously And Must Be Defined From The Context In Which It Is Used.

All of the four note chords which share “1, 3, 5, and 7” in their formulas are in the “family” of seventh chords, including major seventh (1, 3, 5, 7), dominant seventh (1, 3, 5, b7), minor seventh (1, b3, 5, b7), diminished seventh (1, b3, b5, bb7).

*Scale tone seventh chords* are each constructed with four consecutive tones from the tertian cycle. Here is a list of the qualities that occur from the major scale:

<u>numbered tones</u>	<u>letters in C</u>	<u>chord quality</u>	<u>chord name in C</u>
1 3 5 7	C E G B	major seventh	Cma7
2 4 6 1	D F A C	minor seventh	Dm7
3 5 7 2	E G B D	minor seventh	Em7
4 6 1 3	F A C E	major seventh	Fma7
5 7 2 4	G B D F	dominant seventh	G7
6 1 3 5	A C E G	major seventh	Am7
7 2 4 6	B D F A	minor seventh flat five	Bm7 <sup>b</sup> 5

*Dominant seventh chords* are often abbreviated with the term *seventh chords*. A *dominant seventh chord* has the specific formula “1, 3, 5, b7”.



# Chord Types

All chord names and formulas are modeled after the types covered in this section.

## TERTIAN THIRTEENTH CHORDS

Tertian thirteenth chords are constructed entirely in thirds. They use the series of odd numbers from one to thirteen: 1, 3, 5, 7, 9, 11, 13. There are three types: major, minor and dominant.

### Major Thirteenth

A complete major thirteenth chord would have the formula 1, 3, 5, 7, 9, 11, 13. It occurs on the first step of any major scale, by using every other note. However, the complete major thirteenth chord is virtually never used. The combination of the eleventh and third tones is dissonant and contrary to the nature of the rest of the chord. Therefore, parts of the major thirteenth chord are usually voiced without the eleventh. However, I personally think the major seventh suspended fourth chord is beautifully exotic and has many useful voicings.

Cma13 arpeggio: C E G B D F A

C major scale: 1 2 3 4 5 6 7 1 2 3 4 5 6

Cma13

Cma13 VIII

1			
	2	3	
			4 4

1 7 3 6 2

this chord cannot be played in its entirety on the guitar

this partial Cma13 chord contains the essential chord tones

### Minor 13th

A complete major thirteenth chord would have the formula 1,  $\flat 3$ , 5,  $\flat 7$ , 9, 11, 13. It occurs on the second step of any major scale, by using every other note. Using the second step of a major scale as a tone center is called Dorian mode.

A Dm13 chord is constructed on the second step of a C major scale with C major scale tones 2, 4, 6, 1, 3, 5, 7, using the letter names D, F, A, C, E, G, B. If you compared these notes to the D major scale (D, E, F $\sharp$ , G, A, B, C $\sharp$ ), you would need to flat the third and seventh tones of the D major scale to match D Dorian (C major scale). Therefore, the formula for Dorian mode is 1, 2,  $\flat 3$ , 4, 5, 6,  $\flat 7$ .

A minor thirteenth chord can be constructed on the second step of any major scale. In each case, a major scale on its root would have to be altered by flattening the third and seventh to match the notes produced by using the second step of the parent major scale as a tone center (C major is the parent major scale for D Dorian).

Dm13 X

2	3	3	
			4 4
1	b7	b3	6 2

Dm13 arpeggio      C major scale from D to D (two octaves)  
= D Dorian mode      D major scale      Dm13

D F A C E G B    2 3 4 5 6 7 1 2 3 4 5 6 7 1 2    1 2 3 4 5 6 7 1 2 3 4 5 6 7 1    this chord cannot be played in its entirety on the guitar    this partial Dm13 chord contains the essential chord tones

T    8 12    8 10    8 10    9 10    12

A    10 9    10 9    10 9    10 9    10

B    10 8    10 8    10 8    10 8    10

## Dominant 13th

A complete dominant thirteenth chord would have the formula 1, 3, 5,  $\flat 7$ , 9, 11, 13. It occurs on the fifth step of any major scale, by using every other note. Using the fifth step of a major scale as a tone center is called Mixolydian mode. A dominant thirteenth chord is typically named with the ambiguous term “thirteenth chord”, which could also refer to one of the chords in the group: major thirteenth, minor thirteenth and dominant thirteenth.

A G13 chord is constructed on the fifth step of a C major scale with C major scale tones 5, 7, 2, 4, 6, 1, 3, using the letter names G, B, D, F, A, C, E. If you compared these notes to the G major scale (G, A, B, C, D, E, F $\sharp$ ), you would need to flat the seventh tone of the G major scale to match G Mixolydian (C major scale). Therefore, the formula for Mixolydian mode is 1, 2, 3, 4, 5, 6,  $\flat 7$ .

A dominant thirteenth chord can be constructed on the fifth step of any major scale. A major scale on its root would require a flatted seventh to match the notes produced by using the fifth step of the parent major scale (C major is the parent major scale for G Mixolydian).

G13 III

1	2		
		2	
			4 4
1	b7	3	6 2

G13 arpeggio      C major scale from G to G (two octaves)  
= G Mixolydian mode      G major scale      G13

G B D F A C E    5 6 7 1 2 3 4 5 6 7 1 2 3 4 5    1 2 3 4 5 6 7 1 2 3 4 5 6 7 1    this chord cannot be played in its entirety on the guitar    this partial G13 chord contains the essential chord tones

T    5    5    3 5 6 3    5    5

A    3 2 5 3    2 3 5 2 4 5    2 4 5 3 5 6 3    5    5

B    3 2 5 3    3 5 2 3 5 2 4 5    2 4 5 3 5 2 3    3    5

## AUGMENTED AND DIMINISHED CHORDS

### Diminished Triads

A diminished triad is like a minor chord with a flatted fifth. Compared to a major scale on its chord root, it has the formula “1, b3, b5”.

G diminished      G major scale      G diminished arpeggio

scale tones: 1 2 3 4 5 6 7 1      1 b3 b5

T 2  
A 3  
B 5

T 5 2 4 1 3 5 2 3  
A  
B

T 5 3 2  
A  
B

G dim. I

		1	
		2	
4			

### Diminished Seventh Chord

Diminished seventh chords should be called “minor sixth, flat five”. The formula for a diminished seventh chord is “1, b3, b5, 6”.

Within the diminished seventh chord, each tone to the next closest chord tone up or down is a minor third. This is very significant. If you move any diminished seventh chord fingering up or down three frets (not counting the fret on which you begin), all tones are still in the chord and you have another fingering for it.

G diminished seventh      G major scale      G dim. 7 arpeggio

scale tones: 1 2 3 4 5 6 7 1      1 b3 b5 6

T 0  
A 3  
B 5

T 5 2 4 1 3 5 2 3  
A  
B

T 5 3 2 0  
A  
B

G dim. 7 I

		1	
		2	
4			

### Half Diminished Seventh Chord

Compared to a major scale on its chord root, it has the formula “1, b3, b5, b7”. It is like a diminished seventh chord with a “b7” instead of a “b5” (double-flat seven, or six). It is a minor seventh chord with a flatted fifth.

Gm7b5      G major scale      Gm7b5 arpeggio

scale tones: 1 2 3 4 5 6 7 1      1 b3 b5 b7

T 0  
A 3  
B 5

T 5 2 4 1 3 5 2 3  
A  
B

T 5 3 2 0  
A  
B

Gm7b5 I

			1
			2
			3
4			

## Augmented Triad

An augmented triad is like a major chord with a sharpened fifth. Compared to a major scale on its chord root, it has the formula “1, 3, #5”.

G aug. VII

				i			
			2				
		3					

G major scale                      G augmented arpeggio

scale tones: 1 2 3 4 5 6 7 1 1 b3 b5

T									
A	8								
B	10								

T									
A	8								
B	10								

T									
A	8								
B	10								

T									
A	8								
B	10								

T									
A	8								
B	10								

## Seventh Augmented

When chords of four or more different notes include the tones of a major chord and the fifth is sharpened, the chord is an augmented type. The most common of these is the dominant seventh chord with a sharpened fifth. Seventh sharp five (7#5) can also be called “seventh augmented” (7 aug.).

The formula for a dominant seventh chord (such as G7) is “1, 3, 5, b7”, meaning it uses those tones of a major scale. A seventh augmented chord has the formula “1, 3, #5, b7”. It is a fairly dissonant and tension-producing chord, and is used in the more sophisticated and colorful styles like jazz.

G7#5 VI G seventh augmented  
= G7#5

				i			
			2				
		3					

G major scale                      G7#5 arpeggio

1 2 3 4 5 6 7 1 1 3 #5 b7

T	6								
A	8								
B	10								

T									
A	8								
B	10								

T									
A	8								
B	10								

T									
A	8								
B	10								

T									
A	8								
B	10								

## ADD TONE CHORDS

Add tone chords contain a series of thirds, then one or more added tones which do not continue the series of thirds. The added tones may be a second, fourth or sixth in relation to the chord root. Added seconds are called ninths, to imply that they are in the upper range (in pitch) of the chord. Added fourths are called elevenths, again to imply that they are in the upper range.

### Sixth Chords

Both major and minor chords can have an added sixth. Major sixth would have the formula “1, 3, 5, 6” in relation to a major scale on the chord root. Minor sixth would have the formula “1,  $\flat$ 3, 5, 6”.

6 (sixth or major sixth) ..... 1 ..... 3 ..... 5 ..... 6

m6 (minor sixth)..... 1 .....  $\flat$ 3 ..... 5 ..... 6

G6

G major scale      G sixth arpeggio

scale tones: 1 2 3 4 5 6 7 1 1 3 5 6

T 0 3  
A 3 4  
B 5 10

### Add Six Chords

Seventh and ninth chords can have an added sixth. Adding a sixth to a seventh chord implies a thirteenth chord with no ninth nor eleventh. Adding a sixth to a ninth chord implies a thirteenth chord with no eleventh.

In the chord name, a forward slash followed by a “6” is used to indicate the added sixth. Here are the formulas for a few seventh and ninth chords with added sixths:

7/6 (dominant seventh, add six) ..... 1 ..... 3 ..... 5 .....  $\flat$ 7 ..... 6

9/6 (dominant ninth, add six) ..... 1 ..... 3 ..... 5 .....  $\flat$ 7 ..... 9 (=2)

m7/6 (minor seventh, add six) ..... 1 .....  $\flat$ 3 ..... 5 .....  $\flat$ 7 ..... 6

m9/6 (minor ninth, add six) ..... 1 .....  $\flat$ 3 ..... 5 .....  $\flat$ 7 ..... 9 (=2)

G7/6 III

1	2		
		3	
			4

G major scale

G7/6 arpeggio

1 2 3 4 5 6 7 1 2 3 4 5 6 7 1 1 3 5 b7 6

T 6  
A 8  
B 10

3 5 2 3 5 2 4 5 2 4 5 3 5 2 3 5

### Add Nine Chords

Triads and sixth chords can have an added ninth.

/9 (add nine or major add nine) ..... 1 .....3 .....5 .....9 (=2)

m/9 (minor add nine) ..... 1 .....b3 .....5 .....9 (=2)

A/9 V

			1
		2	
		3	4

A major scale

A/9 arpeggio

scale tones: 1 2 3 4 5 6 7 1 2 3 4 5 6 7 1 1 3 5 2(9)

T 7  
A 9

5 7 4 5 7 4 6 7 4 6 7 5 7 4 5 1 3 5 7

Am/9 V

		1	1
		3	4

A major scale

Am/9 arpeggio

1 2 3 4 5 6 7 1 2 3 4 5 6 7 1 1 b3 5 2(9)

T 7  
A 9

5 7 4 5 7 4 6 7 4 6 3 5 7 4 5 7 5 5 7

6/9 (sixth, add nine) ..... 1 .....3 .....5 .....6 .....9 (=2)

m6/9 (minor sixth, add nine) ..... 1 .....b3 .....5 .....6 .....9 (=2)

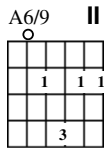

A major scale

A6/9 arpeggio

1 2 3 4 5 6 7 1 2 3 4 5 6 7 1 1 3 5 6 2(9)

T 2 5 7 4 5 7 4 6 7 4 6 7 5 7 4 5 5

A 3 4 5 6 7 7 4 6 7 4 6 7 5 7 4 5

B 0 5 7 4 5 7 4 6 7 4 6 7 5 7 4 5 3 2 5 3

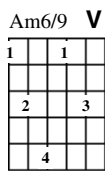

A major scale

Am6/9 arpeggio

1 2 3 4 5 6 7 1 2 3 4 5 6 7 1 1 b3 5 6 2(9)

T 7 5 7 4 5 7 4 6 7 4 6 7 5 7 4 5 5 3 7 4 4

A 3 4 5 6 7 7 4 6 7 4 6 7 5 7 4 5

B 5 5 7 4 5 7 4 6 7 4 6 7 5 7 4 5 5 3 7 4 4

## Add Eleven Chords

Triads and seventh chords can have an added eleventh.

m/11 (minor seventh, add eleven) ..... 1 .....b3 .....4 .....5

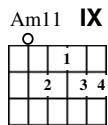

A major scale

Am11 arpeggio

scale tones: 1 2 3 4 5 6 7 1 2 3 4 5 6 7 1 1 b3 5 b7 9(2) 11(4)

T 0 5 7 9 5 7 9 6 7 9 6 7 5 7 9 5 5 8 7 5 9 7

A 3 4 5 6 7 7 4 6 7 4 6 7 5 7 4 5

B 5 5 7 9 5 7 9 6 7 9 6 7 5 7 9 5 5 8 7 5 9 7

m7/11 (minor seventh, add eleven) ... 1 .....b3 .....4 .....5 .....b7

Am11 V

1	1	1	1	1	1

A major scale

Am7/11 arpeggio

1 2 3 4 5 6 7 1 2 3 4 5 6 7 1 1 b3 5 b7 11 (4)

T 6  
A 8  
B 10

5 7 9 5 7 9 6 7 9 6 7 5 7 9 5

5 8 7 5 7

## SUSPENDED CHORDS

Suspended chords contain one or more notes that replace the third. A suspended fourth chord has a fourth instead of a third. A suspended second chord has a second instead of a third. All chord types except diminished, augmented and eleventh chords can have a suspended fourth. All chord types except diminished, augmented and ninth chords can have a suspended second.

SUS. 4 (suspended fourth) ... 1 ..... 4 ..... 5

SUS. 2 (suspended second) .. 1 ..... 2 ..... 5

C sus. 4 I

						1
3	4					

C major scale

C suspended fourth arpeggio

scale tones: 1 2 3 4 5 6 7 1 1 4 5 1

T 1  
A 0  
B 3

3 0 2 3 0 2 0 1 3 3 0 1

C sus. 2 I

						1
3						

C major scale

C suspended second arpeggio

scale tones: 1 2 3 4 5 6 7 1 1 2 5 1

T 0  
A 3  
B 3

3 0 2 3 0 2 0 1 3 0 0 1



7 sus.4 (seventh suspended fourth) ... 1 .....4 .....5 .....b7

9 sus.4 (ninth suspended fourth) ..... 1 .....4 .....5 .....b7 .....9 (=2)

C7 sus. 4 VI

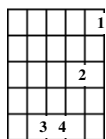

C major scale

C7 sus.4 arpeggio

scale tones: 1 2 3 4 5 6 7 1 1 4 5 b7

C9 sus. 4 X

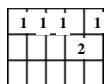

C major scale

C9 sus. 4 arpeggio

scale tones: 1 2 3 4 5 6 7 1 2 3 4 5 6 7 1 1 4 5 b7 9(2)

## “No” CHORDS

To indicate one or more tones to be omitted from a chord, the appendage “no root”, “no third”, “no fifth”, etc. can appear at the end of the chord name. Abbreviations can be used:

- no root .....nr
- no third .....n3
- no fifth .....n5
- no ninth .....n9
- no eleventh .....n11

C major scale

Diagram 1: C9 nr VII (Guitar fretboard: 1 2 3 4)

Diagram 2: C no 3 VIII (Guitar fretboard: 1 3 3)

Diagram 3: C7n5 VII (Guitar fretboard: 1 2 3)

Diagram 4: C13 n5, n9, 11 VIII (Guitar fretboard: 1 2 3 4)

Bass line fret numbers: T ( ), A ( ), B (8 10 7 8 10 7 9 10 7 9 6 8 10 7 8 8 10 8 8 8)

These “no chord” appendages present some ambiguity with chord synonyms:

“Major seventh, suspended second” has the same notes as “major ninth, no third”.

- ma7 sus. 2 .....1 .....2 .....5 .....7
- ma9n3 .....1 .....5 .....7 .....9 (=2)

“Thirteenth, no eleven” has the same notes as “ninth add six”.

- 13n11 .....1 .....3 .....5 .....b7 .....9 (=2) ....13
- 9/6 .....1 .....3 .....5 .....b7 .....9 (=2) ....13

# Identifying The Chord Root

- **The Root Is Usually The Lowest Tone In A Series of Thirds**
- **Recognizing Scale Tone Chords**
- **Incomplete Chords**
- **Add-Tone and Suspended Chords**
- **Synonyms**

The chord root is the note after which a chord is named. It is the letter name at the beginning of the chord name. It may include a sharp or flat in its name, which would be written and spoken immediately after the letter name. If you want to check the validity of a chord name, or don't know what it is, you will need a method of determining the root. In this chapter, you will learn effective methods to determine a chord root.

Cma7 or Am9nr	C6 or Am7	A sus. 4 or D sus. 2
---------------	-----------	----------------------

## The Root Is Usually The Lowest Note In A Series Of Thirds

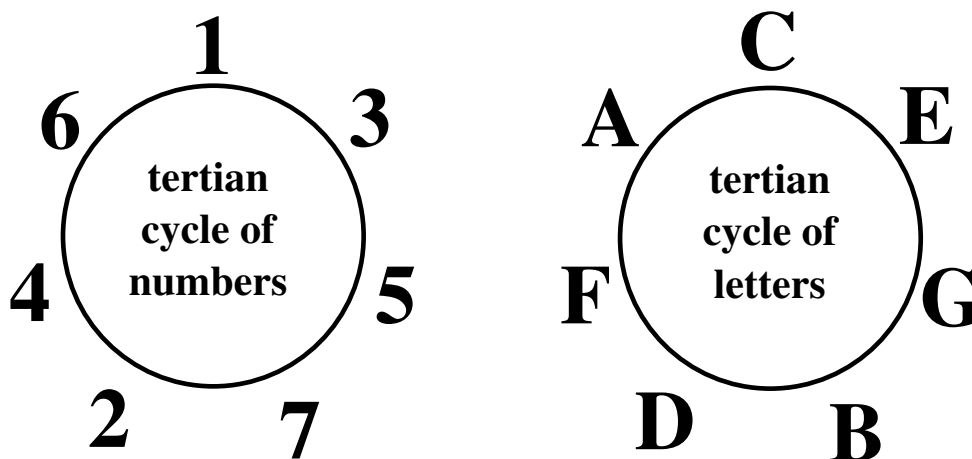

Generally, the lowest-pitched note in a series of thirds is a chord root. You may need to review Chapter 12 on tertian harmony. When the tones of a chord can be arranged to produce an ever-other-note sequence of tones for a major scale, the lowest pitch in the series is usually the chord root. There are often problems with identifying the root in this manner. Chords are not always complete. Sixth chords, add nine chords and suspended chords (among others) do not have the lowest of a series of thirds as their root.

First, see if the letters representing the notes of the chord are unique. No letter should be used twice. Arrange the letter names in thirds (see the tertian cycle of letters above). The first letter in the series of thirds is usually the root of the chord. In the tertian cycle of letters, this would be the letter that begins a clockwise series of letters.

In the Cma7 chord below, the letters can be arranged in the order of thirds: CEGB. C is the chord root of the Cma7 chord. The letters of the Am7 can be arranged in thirds: ACEG. A is the root of the Am7 chord.

The letters of the E7#9 chord do not form a series of thirds. It is an incomplete chord, missing a "B" note. Additionally, the "G" note would need to be spelled F double sharp (F\*). The complete E7#9 chord would be spelled "E, G#, B, D, F\*".

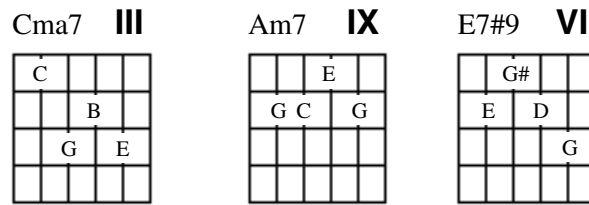

Each “series of thirds” referred to below should be conceived by arranging the notes in thirds as described above.

## Recognizing Scale Tone Chords

You should memorize the major scale tone triad pairs below. Some pairs are unique and others occur on multiple steps of the scale. In either case, it will be very useful to know the possibilities. Major scale tone pairs are a great resource in identifying major scale tone chords with missing tones. You may not realize the usefulness of major scale tone triads until you begin harmonic analysis.

### Major Scale Tone Triad Pairs

<u>root movement</u>	<u>chord types</u>	<u>chord pair</u>	<u>between roots</u>	<u>Key of C</u>	<u>Key of A</u>
stepwise	Major to minor	I II <sup>m</sup>	1 step (2 frets)	C D <sup>m</sup>	A B <sup>m</sup>
		V VI <sup>m</sup>	1 step	G A <sup>m</sup>	E F <sup>#m</sup>
	Major to Major minor to minor minor to Major dimin. to Major	IV V	1 step	F G	D E
		II <sup>m</sup> III <sup>m</sup>	1/2 step (1 fret)	D <sup>m</sup> E <sup>m</sup>	B <sup>m</sup> C <sup>#m</sup>
		III <sup>m</sup> IV	1/2 step	E <sup>m</sup> F	C <sup>#m</sup> D
VII <sup>dim</sup> I	1/2 step	B <sup>dim</sup> C	G <sup>#dim</sup> A		
thirds	Major to minor	I III <sup>m</sup>	2 steps (4 frets)	C E <sup>m</sup>	A C <sup>#m</sup>
		IV VI <sup>m</sup>	2 steps	F A <sup>m</sup>	D F <sup>#m</sup>
	Major to dimin. minor to Major	V VII <sup>dim</sup>	2 steps	G B <sup>dim</sup>	E G <sup>#dim</sup>
		II <sup>m</sup> IV	1 1/2 steps (3 frets)	D <sup>m</sup> F	B <sup>m</sup> D
		III <sup>m</sup> V	1 1/2 steps	E <sup>m</sup> G	C <sup>#m</sup> E
	dimin. to minor	VI <sup>m</sup> I	1 1/2 steps	A <sup>m</sup> C	F <sup>#m</sup> A
VII <sup>dim</sup> II <sup>m</sup>		1 1/2 steps	B <sup>dim</sup> D <sup>m</sup>	G <sup>#dim</sup> B <sup>m</sup>	
perfect fourths	Major to Major	I IV	2 1/2 steps (5 frets)	C F	A D
		V I	2 1/2 steps	G C	E A
	minor to Major minor to minor	II <sup>m</sup> V	2 1/2 steps	D <sup>m</sup> G	B <sup>m</sup> E
		III <sup>m</sup> VI <sup>m</sup>	2 1/2 steps	E <sup>m</sup> A <sup>m</sup>	C <sup>#m</sup> F <sup>#m</sup>
		VI <sup>m</sup> II <sup>m</sup>	2 1/2 steps	A <sup>m</sup> D <sup>m</sup>	F <sup>#m</sup> B <sup>m</sup>
dimin. to minor	VII <sup>dim</sup> III <sup>m</sup>	2 1/2 steps	B <sup>dim</sup> E <sup>m</sup>	G <sup>#dim</sup> C <sup>#m</sup>	

**Triad pairs for other seven tone scales are shown in the Appendix D.**

## USABLE MAJOR SCALE-TONE CHORDS

The chart below lists all the practically usable chords that can be constructed on each step of the major scale. Major scale steps are numbered in Roman numerals across the top of the chart. The specific chord that would occur on any particular major scale step using only tones of the major scale is listed below the roman numeral and the chord type is indicated at the far left. The chord names in the left column (such as “triad” and “seventh”) indicate a general type of chord. The specific chord type that occurs on each scale step is shown beneath the respective roman numeral.

### Usable Major Scale Tone Chords

type	I	II	III	IV	V	VI	VII
triad	major	minor	minor	major	major	minor	diminished
seventh	ma7	m7	m7	ma7	7	m7	m7b5
ninth	9	m9	—	ma9	9	m9	—
eleventh	—	m11	—	ma9#11	11	m11	—
thirteenth	—	m13	—	ma13#11	13	—	—
11 no 3	—	11n3	—	—	11n3	11n3	—
13 no 11	13n11	m13n11	—	13n11	13n11	—	—
sixth	6	m6	—	6	6th	—	—
add 9	/9	m/9	—	/9	/9	m/9	—
6/9 (pentatonic)	.6/9	m6/9	—	6/9	6/9	—	—
sus.4	.sus.4	.sus.4	.sus.4	—	.sus.4	.sus.4	—
sus.2	.sus.2	.sus.2	—	.sus.2	.sus.2	.sus.2	—
7 sus.4	.7sus.4	.7sus.4	.7sus.4	—	.7sus.4	.7sus.4	—
7/11 (pentatonic)	.7/11	m7/11	m7/11	7/#11	7/11	m7/11	m7/11b5
13 sus.	—	13sus.4	—	13#11sus2	13sus.4	—	—
13 sus.	—	13sus.4	—	13#11sus2	13sus.4	—	—

Usuable chords for other seven tone scales are shown in Appendix D.

## Incomplete Chords

When a chord is voiced without certain tones, its name can indicate the missing tones. If such an indication was not included in the chord name or if you weren't given the chord name, you will need to determine which tone or tones is (are) missing.

### SYMBOLS FOR MISSING CHORD TONES

<u>symbol</u>	<u>meaning</u>	<u>symbol</u>	<u>meaning</u>
nr	no root	n9	no ninth
n5	no fifth	n11	no eleventh
n7	no seventh		

## “No Root” CHORDS DETERMINED BY STYLE AND CONTEXT

When you are not given a chord name, you may often need to consider the possibility that the chord has a missing root. The missing root would usually be a third below the lowest tone in a series of thirds. Only consider the missing root when the larger chord it defines would be appropriate to the style of music in which it is involved. The missing root may be played by the bass on another instrument.

### Tertian Chords Without a Root

When the tones of a chord can be arranged into a series of thirds, also consider a “missing” chord root a major third or a minor third below the lowest tone in the series. The resultant chord may be more typical of the style in which it is used and/or may establish a more logical chord root progression.

The diagram illustrates the fretboard diagrams and a guitar chord chart for various tertian chords without a root. The chords shown are Dm7 no root, Dm7, Dm9 no root, Dm9, Cma7 no root, Cma7, A9 no root, and A9. The fretboard diagrams show fingerings for each chord. Below the diagrams is a guitar chord chart with strings T, A, B and frets 1, 2, 3, 4, 7, 11.

No root chords constructed in thirds are usually complete chords without the root under a different name. Dm7 no root is F major. Dm9 no root is F major seventh.

The Dm7 chord in the example above uses every other tone of a C major scale from “D” to “F” (D, F, A, C). Without the “D” note, it could be an F major chord or a Dm7 no root chord. The Dm9 chord in the example above uses every other tone of a C major scale from “D” to “E” (D, F, A, C, E). Without the “D” note, it could be an F major seventh chord or a Dm9 no root chord. In a chord progression where the Dm7 or Dm9 chord would be more typical, such as “Dm7(9) G7 Cma7”, you might suspect the “Dm7 no root” or “Dm9 no root” chord.

To be able to recognize no root chords constructed in thirds, you should memorize the following:

- the definition of *tertian* chords, which are chords constructed strictly in thirds, following the numbered scale tone cycle 1, 3, 5, 7, 2, 4, 6, 1, etc.
- the seven major scale tone tertian triads: I major, II minor, III minor, IV major, V major, VI minor, VII diminished
- the tertian cycle of triads: I major, III minor, V major, VII diminished, II minor, IV major, VI minor, I major, etc.
- the seven major scale tone tertian seventh chords: Ima7, IIm7, IIIIm7, IVma7, V7, VIIm7, VIIIm7b5
- the tertian cycle of seventh chords: Ima7, IIIIm7, V7, VIIIm7b5, IIm7, IVma7, VIIm7, Ima7, etc.

## Suspended Chords Without a Root

“No root” chords with a suspended fourth or suspended second could not have their tones arranged in a continuous series of thirds. In place of thirds, suspended second and suspended fourth chords cause major second, perfect fourth and/or consecutive perfect fifth intervals. Two consecutive perfect fifths, would be an interval of a perfect fifth occurring above the upper tone in a perfect fifth, such as (C up to G, up to D).

A sus. 4 nr   A sus. 4   A   A7 sus. 4 nr   A7 sus. 4   A7   A sus. 2 nr   A sus. 2   A   A7 sus. 2 nr   A7 sus. 2   A7

## MISSING TONES WITHIN A SERIES OF THIRDS

Two notes a fifth apart can constitute a triad without a third. With an awareness of *scale tone triad pairs* covered earlier, the surrounding chords can suggest the quality of the completed triad. It can be useful to know what the completed chords would be for the purposes of improvisation and arranging. In improvising, you would typically emphasize the notes of the completed chord in your melody. In arranging, you may want to use a more complete chord in another instrument part.

## No Third Chords

**Power Chords.** Perfect fifths are often used in modern hard rock. They are typically referred to as “power chords”. Though you may not need to complete the chord in the accompaniment part (it may in fact be inappropriate for the style), it would be useful to know what the completed triad.

In the example below, the G major scale tone chords are complete triads. Compare the chords in the power chord example to their counter parts in the G major scale-tone chords to find that each chord is missing its highest note. These G major scale tone chords are voiced with their roots as the lowest pitch, their fifths as the middle pitch, and their thirds as the highest pitch.

**power chord example**                      **G major scale-tone chords**

G    Am    Bm    C            D    Em    F#dim    G



**Ninth, No Third.** The example below shows a major ninth chord without a third. It could also be named as a major triad on the fifth, with its fourth in the bass (A major triad with D bass).

Dma9 n3 <b>V</b>				
1		9		
		7		
	5			

A/D <b>V</b>				
4		5		
		3		
	1			

## No Fifth

Chords with four or more different notes often have no fifth. Like the root, it can be suggested in the context of the progression (imagined by the listener) or may be played by another instrument. In the example below, the first three chords are missing their fifths. In the last three chords, each chord has the same notes as the version to its left with the same name *with* the fifth included. The fingerings had to be changed radically to allow fingering the notes.

D7#9 <b>IV</b>				
	3			
1	b7			
				#9

G13 <b>III</b>				
1	b7			
		3		
			13	

Cma9 <b>II</b>				
	3			
1			2	
			7	

D7#9 <b>IX</b>				
	3			
1	b7 #9	5		

G13 <b>III</b>				
1	b7			
		3		
	5		13	

Cma9 <b>VII</b>				
	3	2		
1			5	
	7			

## "No Seventh" Is Not Commonly Used

Chords without a seventh are given add-tone names that exclude the seventh. This is done because the seventh is so important in the basic character of a seventh, ninth, eleventh or thirteenth chord (notice the odd number series). When the seventh is omitted, the chord is named regarding all of the notes below the seventh with an additional reference to the notes above the seventh. For example, "1, 3, 5, b7, 9" without the seventh is called "major (1, 3, 5) add nine".

When the thirteenth is added without the seventh, the thirteenth is referred to as a sixth. For example, "1, 3, 5, 9, 13" would be called major sixth, add nine (rather than thirteenth, no seven, no eleven).

<del>C13 n7, n11 <b>II</b></del>				
	3	6		
1			9	5

C6/9 <b>II</b>				
	3	6		
1			9	5

## No Ninth

A missing ninth in a thirteenth chord is designated with “no ninth”. When an eleventh chord is missing its ninth, it is referred to as “seventh, add eleven”, usually written “7/11”. There are various types of seven add eleven chords, including “7/11”, “m7/11” and “7/#11”.

Am11 n9 <b>V</b>				
1	11	b7	b3	5

Am7/11 <b>V</b>				
1	11	b7	b3	5

A13 n9 n11 <b>V</b>				
1		b7		
			3	
5				13

## No Eleventh

A missing eleventh in a thirteenth chord is designated with “no eleventh”. No eleventh chords may also be referred to as seventh or ninth chords with an added sixth (the sixth is the same tone as the thirteenth).

A13 n9, n11 <b>V</b>				
1		b7		
			3	
5				13

A7/6 <b>V</b>				
1		b7		
			3	
5				13

A13 n5, n11 <b>V</b>				
1		b7		
			3	
				13 9

A9/6 <b>V</b>				
1		b7		
			3	
				13 9

# Add-Tone And Suspended Chords

## ADD TONE CHORDS

### Sixth Chords

When the bass part or chord name indicates that the next-to-lowest tone in a series of thirds is the chord root, it is a sixth chord. The series of thirds would be conceived by arranging the chord tones in thirds. Sixth chords can also be named after the lowest tone in the series of thirds, which would make it some type of seventh chord.

C6 <b>IX</b>		
		3
5	1	6

Am7 <b>IX</b>		
		5
b7	b3	1

Cm6 <b>VIII</b>		
		b3
5	1	6

Am7b5 <b>IX</b>		
		b5
b7	b3	1

C6 <b>IX</b>		
		E
G	C	A

Am7 <b>IX</b>		
		E
G	C	A

Cm6 <b>VIII</b>		
		Eb
G	C	A

Am7b5 <b>IX</b>		
		Eb
G	C	A

thirds: A C E G                      thirds: A C Eb G

## Add Nine Chords

Ninths can be added to triads and to sixth chords. “/9” designates “add nine”.

A/9	<b>V</b>	Am/9	<b>V</b>	A dim.7/9	<b>IV</b>	A dim.7/9	<b>IV</b>
1	3	1	b3	1	3	1	b3
5	5	5	5	6	5	6	b5
9	9	9	9	9	9	9	9

## Multiple Added Tones

Usually, when you indicate multiple added tones in a chord name, the alternate name would be complicated also. The alternate name usually would have to specify missing tones.

E7/6/#11	<b>IX</b>	E13#11 n9	<b>IX</b>	E13#11 n9	<b>IX</b>
1	3	1	3	1	2
6	#11	6	#11	2	3
b7	b7	b7	b7	4	1

fingers

## SUSPENDED CHORDS

When you are unable to arrange the tones of a chord in thirds but instead have a series of three notes that are second and a fourth apart, suspect a suspended chord.

### Suspended Fourth Chords

A suspended fourth triad has tones a perfect fourth and a perfect fifth above the root. A seventh suspended fourth chord has tones a fourth, fifth and seventh above the root.

A sixth suspended fourth chord is better named with its fourth as a root, where it would be a major add nine chord.

### Suspended Second Chords

A suspended second chord has tones a major second and a perfect fifth above the root. The notes of a suspended fourth chord may often be arranged so that the first two intervals above the lowest tone are a second and a fourth, where the chord might be a suspended second type. A fourth tone must usually qualify as a seventh, but can be a sixth.

A sixth suspended second chord is better named with its second as a root, where it would be a seventh suspended fourth.

## Synthetic Suspended Chords

**Suspended Sharp Four.** A suspended chord can include a sharp four, instead of a fourth. The sharp four would resolve to the major third.

**Major Seventh Suspended Chords.** A major seventh chord can have its third suspended by replacing it with a fourth or second.

**Minor Major Seventh Suspended Chords.** A minor major seventh chord is a minor chord with a major seventh (1  $\flat$ 3, 5 7). Like the major seventh, it can have its third suspended by replacing it with a fourth or second.

**Diminished Seventh Suspended Chords.** A diminished seventh chord can have its third suspended by replacing it with a fourth. However, this produces a two synonyms which may be better names: m6 on the  $\flat$ 3 of the dim. 7 sus. 4 or m7 $\flat$ 5 on the  $\flat$ 5 of the dim. 7 sus. 4.

## COMBINED ADD TONE AND SUSPENDED CHORDS

These are usually better named with another chord tone as the root.

### Sixth Suspended Fourth

These types were mentioned earlier. A sixth suspended fourth chord is better named with its fourth as a root, where it would be a major add nine chord. A sixth suspended second chord is better named with its second as a root, where it would be a seventh suspended fourth.

### Add Nine Suspended Fourth

These could also be named suspended 2/4.

### Seventh Or Ninth Add Tone With Suspended Fourth

Seven add 6 suspended fourth becomes a minor ninth no fifth with its fourth in the bass.

Ninth add 6 suspended fourth becomes a minor ninth with its fourth in the bass.

## Synonyms

### INTERVAL NAME VERSUS TRIAD, NO FIFTH

A major triad without a fifth is a major third. A minor triad without a fifth is a minor third. A suspended fourth chord without a fifth is a perfect fourth.

## RELATIVE SIXTH AND SEVENTH

### Relative Major Sixth and Minor Seventh

A major sixth chord changes to a minor seventh by assigning the sixth as the root. Conversely, a minor seventh chord changes to a major sixth by assigning its third as the root.

### Relative Minor Sixth And Minor Seventh Flat Five

A minor sixth chord changes to a minor seventh flat five by assigning the sixth as the root. Conversely, a minor seventh flat five chord changes to a minor sixth by assigning its third as the root.

## REPEATING INTERVAL CHORDS

### Augmented Triad

Each tone in an augmented triad is a major third above and below the next. It is a “stack” of major thirds. Fingerings may be inverted by moving up and down the fretboard in intervals of a major third (four frets, not counting the one you begin on).

### Diminished Seventh

Each tone in an diminished triad is a minor third above and below the next. It is a “stack” of minor thirds. Fingerings may be inverted by moving up and down the fretboard in intervals of a minor third (three frets, not counting the one you begin on).

### Seventh Flat Five

Each tone in  $7b5$  chord is a diminished fifth (“ $b5$ ”) above and below the next. Fingerings may be inverted by moving up and down the fretboard in intervals of a diminished fifth (six frets, not counting the one you begin on).

### Ninth Flat Five, Sharp Five

Each tone in an  $9b5\#5$  chord is a diminished fifth (“ $5$ ”) above and below the next. It is a “stack” of major seconds. Fingerings shouldn't be, but can be inverted by moving up and down the fretboard in intervals of a major second (every other fret). Inversions with the  $b7$  and  $9$  in the bass should be avoided.

## FLAT FIVE SUBSTITUTES

Many chords with altered fifths and/or altered ninths *which include a flatted fifth* can also be named with the note on their flatted fifth as a root. The  $7b5$  and  $9b5\#5$  chords mentioned above are flat five substitutes.

## INCOMPLETE VERSUS SUSPENDED CHORDS

### **Ninth No Third Versus Seventh Suspended Second**

If the second resolves to the third, use the suspended second name. Otherwise use ninth no third if the chord sounds resolved in context or use the seventh suspended second name if it sounds unresolved in context.

### **Eleventh No Third Versus Ninth Suspended Fourth**

If the second resolves to the third, use the suspended second name. Otherwise use eleventh no third if the chord sounds resolved in context or use the ninth suspended second name if it sounds unresolved in context.

### **Thirteenth No Eleven Versus Ninth Add Six**

You should usually use the thirteenth no eleven version of the name, since it is more common. However, the ninth add six name is more precise.

### **Thirteenth No Nine, No Eleven Versus Seventh Add Six**

As with the chord above, usually use the thirteenth no nine, no eleven name, since it is more common, though the seventh add six name is more precise.

## CHORD NAME DECISIONS MADE ACCORDING TO STYLE AND FAMILIARITY

Sixth chords are typical of swing music (early to mid twentieth century jazz dance music). In an ambiguous situation, where it is difficult to decide whether to name a chord as a minor seventh or as a major sixth, use the sixth version if the music has elements of swing.

Steely Dan music uses a lot a major ninth no third chords. They could be called major seventh, suspended second, but in context, they sound resolved, so they should use the major ninth no third version of the chord name.

If the music reader will be able to voice chords well, use specific versions of names like “7/6”, instead of the synonym 13 n9n11 (thirteenth, no nine no eleven).

# Essential Chord Tones



- **The Third, Seventh & What's In The Name**
- **Implied Chord Tones**
- **Essential Chord Tone Charts**

# THE THIRD, THE SEVENTH & WHAT'S IN THE NAME

To summarize which tones need to be included in a chord, this phrase works: “The third, the seventh, and any note referred to in the chord name”.

## OMITTED TONES

### The Imagination Fills In For Omitted Tones

Except for an omitted root, there are usually options for what the omitted tone could have been. An omitted third could be a major third or a minor third. An omitted fifth could have been a perfect fifth, an augmented fifth or a diminished fifth. When the chord from which a note was omitted is part of a group of chords which derived from a seven tone scale (such as the major scale), the omitted tones tend to suggest the version implied by the harmonized seven tone scale. A thorough knowledge of the usable chords constructed from the major scale is very useful in determining the likely quality of an incomplete chord. See Chapter 13, Usable major Scale Tone Chords and Appendix G: Scale Tone Chords.

### The Root And Fifth Can Be Omitted

The root and fifth of a chord are so obvious that they can often be omitted. The listener will imagine them within the context of the music. This is more true for chords of four or more different notes. Triads sound better with all three notes included.

**Twelve Bar Blues In C Example.** In the rhythm guitar part of Twelve Bar Blues In C example below, no “C” note is ever played, yet most listeners can easily tell that the piece is in the key of “C”. Not only is the root of the C9 chord omitted, every occurrence of the “C” note was omitted. Each chord is played for one bar.

C9 nr <b>VII</b>	F9 n5 <b>VII</b>	C9 nr <b>VII</b>	C9 nr <b>VII</b>	F9 n5 <b>VII</b>	F9 n5 <b>VII</b>																																																																
<table border="1" style="border-collapse: collapse; width: 40px; height: 40px; text-align: center;"><tr><td>1</td><td>2</td><td></td></tr><tr><td></td><td>3</td><td>4</td></tr><tr><td></td><td></td><td></td></tr></table>	1	2			3	4				<table border="1" style="border-collapse: collapse; width: 40px; height: 40px; text-align: center;"><tr><td></td><td>1</td><td></td></tr><tr><td>2</td><td>3</td><td>4</td></tr><tr><td></td><td></td><td></td></tr></table>		1		2	3	4				<table border="1" style="border-collapse: collapse; width: 40px; height: 40px; text-align: center;"><tr><td>1</td><td>2</td><td></td></tr><tr><td></td><td>3</td><td>4</td></tr><tr><td></td><td></td><td></td></tr></table>	1	2			3	4				<table border="1" style="border-collapse: collapse; width: 40px; height: 40px; text-align: center;"><tr><td>1</td><td>2</td><td></td></tr><tr><td></td><td>3</td><td>4</td></tr><tr><td></td><td></td><td></td></tr></table>	1	2			3	4				<table border="1" style="border-collapse: collapse; width: 40px; height: 40px; text-align: center;"><tr><td></td><td>1</td><td></td></tr><tr><td>2</td><td>3</td><td>4</td></tr><tr><td></td><td></td><td></td></tr></table>		1		2	3	4				<table border="1" style="border-collapse: collapse; width: 40px; height: 40px; text-align: center;"><tr><td></td><td>1</td><td></td></tr><tr><td>2</td><td>3</td><td>4</td></tr><tr><td></td><td></td><td></td></tr></table>		1		2	3	4													
1	2																																																																				
	3	4																																																																			
	1																																																																				
2	3	4																																																																			
1	2																																																																				
	3	4																																																																			
1	2																																																																				
	3	4																																																																			
	1																																																																				
2	3	4																																																																			
	1																																																																				
2	3	4																																																																			
C9 nr <b>VII</b>	C9 nr <b>VII</b>	G7/6 n5 <b>VIII</b>	F9 n5 <b>VII</b>	C9 nr <b>VII</b>	G7/6 n5 <b>VIII</b>	C9 nr <b>VII</b>																																																															
<table border="1" style="border-collapse: collapse; width: 40px; height: 40px; text-align: center;"><tr><td>1</td><td>2</td><td></td></tr><tr><td></td><td>3</td><td>4</td></tr><tr><td></td><td></td><td></td></tr></table>	1	2			3	4				<table border="1" style="border-collapse: collapse; width: 40px; height: 40px; text-align: center;"><tr><td>1</td><td>2</td><td></td></tr><tr><td></td><td>3</td><td>4</td></tr><tr><td></td><td></td><td></td></tr></table>	1	2			3	4				<table border="1" style="border-collapse: collapse; width: 40px; height: 40px; text-align: center;"><tr><td>1</td><td></td><td>2</td></tr><tr><td></td><td>3</td><td>4</td></tr><tr><td></td><td></td><td></td></tr></table>	1		2		3	4				<table border="1" style="border-collapse: collapse; width: 40px; height: 40px; text-align: center;"><tr><td></td><td>1</td><td></td></tr><tr><td>2</td><td>3</td><td>4</td></tr><tr><td></td><td></td><td></td></tr></table>		1		2	3	4				<table border="1" style="border-collapse: collapse; width: 40px; height: 40px; text-align: center;"><tr><td>1</td><td>2</td><td></td></tr><tr><td></td><td>3</td><td>4</td></tr><tr><td></td><td></td><td></td></tr></table>	1	2			3	4				<table border="1" style="border-collapse: collapse; width: 40px; height: 40px; text-align: center;"><tr><td></td><td>1</td><td></td></tr><tr><td>2</td><td>3</td><td></td></tr><tr><td></td><td></td><td>4</td></tr></table>		1		2	3				4	<table border="1" style="border-collapse: collapse; width: 40px; height: 40px; text-align: center;"><tr><td>1</td><td>2</td><td></td></tr><tr><td></td><td>3</td><td>4</td></tr><tr><td></td><td></td><td></td></tr></table>	1	2			3	4			
1	2																																																																				
	3	4																																																																			
1	2																																																																				
	3	4																																																																			
1		2																																																																			
	3	4																																																																			
	1																																																																				
2	3	4																																																																			
1	2																																																																				
	3	4																																																																			
	1																																																																				
2	3																																																																				
		4																																																																			
1	2																																																																				
	3	4																																																																			

**Two Five One In C Example.** In the rhythm guitar part of Two Five One In C example below, the fifth of each chord is omitted, yet the chords sound relatively complete. Each chord is played for two beats.

Dm7 n5 <b>V</b>	G7 n5 <b>IV</b>	Cma7 n5 <b>III</b>	Am7 n5 <b>V</b>	Dm7 n5 <b>V</b>	G7 n5 <b>IV</b>	Cma7 n5 <b>III</b>																																																															
<table border="1" style="border-collapse: collapse; width: 40px; height: 40px; text-align: center;"><tr><td>2</td><td>2</td><td></td></tr><tr><td></td><td></td><td>4</td></tr><tr><td></td><td></td><td></td></tr></table>	2	2				4				<table border="1" style="border-collapse: collapse; width: 40px; height: 40px; text-align: center;"><tr><td></td><td>1</td><td></td></tr><tr><td>2</td><td></td><td></td></tr><tr><td></td><td></td><td>4</td></tr></table>		1		2					4	<table border="1" style="border-collapse: collapse; width: 40px; height: 40px; text-align: center;"><tr><td>1</td><td></td><td></td></tr><tr><td></td><td>2</td><td></td></tr><tr><td></td><td></td><td>4</td></tr></table>	1				2				4	<table border="1" style="border-collapse: collapse; width: 40px; height: 40px; text-align: center;"><tr><td>1</td><td>1</td><td></td></tr><tr><td></td><td></td><td></td></tr><tr><td></td><td></td><td>4</td></tr></table>	1	1							4	<table border="1" style="border-collapse: collapse; width: 40px; height: 40px; text-align: center;"><tr><td>2</td><td>2</td><td></td></tr><tr><td></td><td></td><td>4</td></tr><tr><td></td><td></td><td></td></tr></table>	2	2				4				<table border="1" style="border-collapse: collapse; width: 40px; height: 40px; text-align: center;"><tr><td></td><td>1</td><td></td></tr><tr><td>2</td><td></td><td></td></tr><tr><td></td><td></td><td>4</td></tr></table>		1		2					4	<table border="1" style="border-collapse: collapse; width: 40px; height: 40px; text-align: center;"><tr><td>1</td><td></td><td></td></tr><tr><td></td><td>2</td><td></td></tr><tr><td></td><td></td><td>4</td></tr></table>	1				2				4
2	2																																																																				
		4																																																																			
	1																																																																				
2																																																																					
		4																																																																			
1																																																																					
	2																																																																				
		4																																																																			
1	1																																																																				
		4																																																																			
2	2																																																																				
		4																																																																			
	1																																																																				
2																																																																					
		4																																																																			
1																																																																					
	2																																																																				
		4																																																																			
			<table border="1" style="border-collapse: collapse; width: 40px; height: 40px; text-align: center;"><tr><td></td><td></td><td></td></tr><tr><td></td><td></td><td></td></tr><tr><td></td><td></td><td>4</td></tr></table>									4																																																									
		4																																																																			



## THE ESSENTIAL THIRD

In chords with a perfect fifth (which most chords do), the third determines whether the chord is basically major or minor. A chord with a perfect fifth and a major third ( $\sharp 3$ ) gives the chord a bright mood and make the chord major. A chord with a perfect fifth and a minor third ( $\flat 3$ ) gives the chord a dark mood and makes the chord minor.

When the third is missing (yet the chord has a perfect fifth), the missing note may be present in neighboring chords, which would suggest that the chords quality, but not as distinctly.

## THE ESSENTIAL SEVENTH

The seventh determines the upper coloring of the chord. A major seventh ( $\sharp 7$ ) chord tone creates a dissonance in being a half step below its root, and usually has a lower scale-tone neighbor is down a whole step (sometimes one and one half steps). A minor seventh ( $\flat 7$ ) chord tone often has a lower scale-tone neighbor down a half step, with creates tension and suggests a downward resolution.

### Two Perfect Fifth Intervals Within Major Seventh and Minor Seventh Chords

A major seventh chord has a major seventh ( $\sharp 7$ ), perfect and major third above the root. This constitutes two perfect fifths: from the root to the fifth and from the major third to the major seventh. Likewise, a minor seventh chord has two perfect fifths: from the root to the fifth and from the minor third ( $\flat 3$ ) to the minor seventh ( $\flat 7$ ).

### A Dominant Seventh Chord's Tritone Between Its Third And Seventh

A *tritone* is a diminished fifth interval, so called because it is three whole tones. A dominant seventh chord (1, 3, 5,  $\flat 7$ ) has a tritone between its third and seventh, which creates dual tensions. The third in a dominant seventh chord usually leads up a half step to a tone in the chord that follows it. The minor seventh ( $\flat 7$ ) in a dominant seventh chord usually leads down a half step to a tone in the next chord.

### The Sub-Triad Defined By The Seventh

A sub-triad is a group of notes which can be extracted from a larger chord and which, by themselves, form a complete triad. The addition of a seventh to a triad defines the quality of a *sub-triad* created by the third, fifth and seventh of the chord. Here are the sub-triads created by common seventh chord types:

<u>seventh chord type</u>	<u>formula</u>	<u>sub-triad on root</u>	<u>sub-triad on third</u>
major seventh	1, 3, 5, 7	major	minor
dominant seventh	1, 3, 5, $\flat 7$	major	diminished
minor seventh	1, $\flat 3$ , 5, $\flat 7$	minor	major
minor seventh flat five	1, $\flat 3$ , $\flat 5$ , $\flat 7$	diminished	minor
diminished seventh	1, $\flat 3$ , $\flat 5$ , $\flat \flat 7$	diminished	diminished
dominant seventh flat five	1, 3, $\flat 5$ , $\flat 7$	major $\flat 5$	1, 2, $\flat 5$
dominant seventh sharp five	1, 3, $\sharp 5$ , $\flat 7$	augmented	major $\flat 5$
minor (major seventh)	1, $\flat 3$ , 5, $\flat 7$	minor	augmented

## NUMBERED TONES INDICATED IN THE CHORD NAME

### Odd-Numbers Or “6” Immediately After The Letter Name

The letter name part of a chord name may be followed by a flat or sharp, such as “B $\flat$ ” or “C $\sharp$ ”. When one of the odd numbers seven, nine, eleven or thirteen appears immediately after the letter name, they imply that the chord contains all odd numbers up through that number. A seventh chord contains a root (1), third (3), fifth (5) and seventh (7). “9” implies 1, 3, 5, 7, 9. “11” implies 1, 3, 5, 7, 9 and 11. “13” implies 1, 3, 5, 7, 9, 11 and 13.

**Major Seventh Type Chords.** If “ma”, “maj”, “major” or “ $\Delta$ ” appears between the letter name and the odd number, the chord has a major seventh (“7”, as opposed to “ $\flat$ 7”). This constitutes a major seventh type chord, since it includes the numbered tones for a major seventh: 1, 3, 5 and 7. Examples: Cma7, Cma9, Bbmaj7, Bbma9 $\sharp$ 11.

**Dominant Seventh Type Chords.** If nothing appears between the letter name and the odd number, the chord has a flatted seventh ( $\flat$ 7) and a major third ( $\sharp$ 3). This constitutes a dominant seventh type chord, since it includes the numbered tones 1, 3, 5 and  $\flat$ 7. Examples: C7, C9, B $\flat$ 7, B $\flat$ 9 $\sharp$ 11.

**Minor Seventh Type and Half Diminished Chords.** If “m” appears between the letter name and the odd number, the chord is minor and has a flatted seventh. This constitutes a minor seventh type chord, with 1,  $\flat$ 3, 5 and  $\flat$ 7. If the chord also has a flatted fifth (containing 1,  $\flat$ 3,  $\flat$ 5,  $\flat$ 7), it is a minor seventh flat five, sometimes called a *half diminished* chord (“full” diminished would be 1  $\flat$ 3,  $\flat$ 5  $\flat$ 7 or 1  $\flat$ 3,  $\flat$ 5, 6). The symbol “ $\emptyset$ ” is used to indicate half diminished. Examples: Cm7, Cm9, Bbm7, Bbm7 $\flat$ 5, B $\flat$  $\emptyset$ 7.

**Minor, Major Seventh Type Chords.** If “m(ma7)”, “m(maj7)”, “m(major 7)”, “m( $\sharp$ 7)”, “m(nat7) or “m(natural 7) appears immediately after the letter name, the chord is a “minor, major seventh” type with 1,  $\flat$ 3, 5 and  $\sharp$ 7. Examples: Cm(ma7), Cm( $\sharp$ 7), Cm(maj7).

Likewise, if “m9(ma7)”, “m9(maj7)”, “m9(major 7)”, “m9( $\sharp$ 7)”, “m9(nat7) or “m9(natural 7) appears immediately after the letter name, the chord is a “minor ninth, major seventh” type with 1,  $\flat$ 3, 5,  $\sharp$ 7 and 9. Examples: Cm9(ma7), Cm9( $\sharp$ 7), Cm9(maj7).

**Sixth Type Chords.** If “6” appears immediately after the letter name, the chord is a sixth type with 1, 3, 5 and 6. Examples: C6, D $\flat$ 6. If “m6” appears immediately after the letter name, the chord is a minor sixth type with 1, 3, 5 and 6. Examples: Cm6, Fm6.

### Altered Tones

Altered tones are shown at the end of a chord name. They are usually altered fifths or ninths, but can also be sharped elevenths.

In the rare cases where a chord is altered *and* suspended, the altered tones are next-to-last in the chord name, followed by the indication of suspended fourth or suspended second. For example, 7 $\flat$ 9 sus.4 (seventh flat nine, suspended fourth) includes the altered tone “ $\flat$ 9” which is shown just before the “sus. 4” indication at the end.

### Added Tones

The most typical added tones are sixths and ninths, but can also be elevenths or (rarely) flatted sixths.

## Suspended Tones

In a suspended chord the third is replaced with a second or fourth (most commonly the fourth). The third it replaces could be a major third (“ $\sharp 3$ ”) or a minor third (“ $\flat 3$ ”). Suspended chords imply, but do not demand resolution to (being followed by) the same chord with the third instead of the second or fourth.

**Suspended Fourth Type.** When “sus4” or “sus” is shown in a chord name, it indicates that the third of the chord has been replaced with the fourth. The “default” version of a suspended chord is the suspended fourth, although suspended second chords are becoming fairly common. “Csus4” would include “C”, “F” and “G” notes, expressing the chord formula “1, 4, 5.” “Cma7sus4” would include “C”, “F”, “G” and “B” notes (1, 4, 5, 7).

Theoretically, a suspended chord could replace the third with an augmented fourth ( $\sharp 4$ ). This would be called “sus $\sharp 4$ ”. “C7sus $\sharp 4$ ” would include “C”, “F $\sharp$ ”, “G” and “B $\flat$ ” notes, expressing the chord formula “1,  $\sharp 4$ , 5,  $\flat 7$ ”.

**Suspended Second Type.** When “sus2” is shown in a chord name, it indicates that the third (major or minor) of the chord has been replaced with the second. “Csus2” would include “C”, “D” and “G” notes (1, 2, 5). “Cma7sus2” would include “C”, “D”, “G” and “B” notes (1, 2, 5, 7).

## Combinations

Chords can have combinations of altered, added and suspended tones. Here are some examples:

<u>chord name</u>	<u>chord formula</u>	<u>letter names in C</u>
C7b9sus4	1, 4, 5, b7, b9	C, F, G, Bb, Db
C6/9sus4	1, 4, 5, 6, 9	C, F, G, A, D
C7/6 $\sharp 5$	1, 3, $\sharp 5$ , 6, b7	C, E, G $\sharp$ , A, B $\flat$

# Implied Chord Tones

A chord name can imply tones in the triad part of the chord. This includes “augmented”, “diminished” and “suspended” as part of a chord name.

## AUGMENTED

Augmented chords imply a sharped fifth ( $\sharp 5$ ) and a major third ( $\sharp 3$ ). An augmented triad may be indicated with either “aug” or “+” after the letter name of the chord,. C augmented (C, E, G $\sharp$ ) could be written “Caug” or “C+”. Seventh, ninth, eleventh and thirteenth chords can use the “aug” or “+” symbols (C13aug or C13+), but it is better to use “ $\sharp 5$ ” after the chord name (C13 $\sharp 5$ ).

## DIMINISHED

**Diminished Triads.** Diminished chords imply a flatted fifth ( $\flat 5$ ) and a minor third ( $\flat 3$ ). A diminished triad may be indicated with “dim” after the letter name of the chord,. C diminished (C, E $\flat$ , G $\flat$ ) should be written “Cdim”.

**Diminished Seventh Chords.** The formula for a diminished seventh chord is “1,  $\flat 3$ ,  $\flat 5$ ,  $\flat 7$ ”. Diminished seventh chords should be referred to verbally as “diminished seventh”, not “diminished”. A “Cdim7” chord would contain the notes “C”, E $\flat$ , “G $\flat$ ” and “B $\flat\flat$ ” (= A).

You may be wondering why the “B $\flat\flat$ ” note in the “Cdim7” chord is not called “A”. Me, too. A simpler name for the diminished seventh chord would be “m $\flat$ 5” (minor sixth, flat five). The diminished seventh name was coined at a time in the evolution of music that four note chords (four *different* notes) were all to be some kind of seventh chords, since there were few fourth note chords in use.

Diminished seventh chords are diminished triads with an added double-flat seventh ( $\flat\flat$ 7), which is the interval of a diminished seventh above the chord root. A “diminished seventh” interval is a half step smaller than a minor seventh interval.

**Half Diminished Seventh Chords.** The formula for a half diminished seventh chord is “1,  $\flat$ 3,  $\flat$ 5,  $\flat$ 7”. They can be written “m7 $\flat$ 5” or “ $\emptyset$ 7” (Cm7 $\flat$ 5 or C $\emptyset$ 7, for example). I prefer the name “m7 $\flat$ 5. It is more explanatory. A “Cm7 $\flat$ 5” chord would contain the notes “C”, “E $\flat$ ”, “G $\flat$ ” and “B $\flat$ ”.

Half diminished seventh chords have a diminished triad as their basis, but have a flatted seventh ( $\flat$ 7) instead of a double flat seventh. So, the tone added to the diminished triad is a minor seventh interval above the root, instead of a diminished seventh.

## SUSPENDED

If a chord name uses the word suspended or the abbreviation “sus.” without a number following it (such as sus. 4), you should assume that it is a suspended fourth. See “Numbered Tones Indicated In The Chord Name/Suspended Tones” above.

# Essential Chord Tone Charts

On the following pages, each set of essential tones is shown with a filled circle (black dot). The options for tones added to those essential tones are shown with empty circles (white dots). Each diagram can generate many chord fingerings, sometimes over twenty!

### 1. Dominant 7th Type Chords

*Blackened dots are essential chord tones, circles are optional chord tones.*

The image displays a collection of guitar chord diagrams for dominant 7th type chords. Each diagram is a 6-string fretboard with dots representing chord tones. Black dots indicate essential chord tones, while white circles indicate optional chord tones. The chords are organized as follows:

- Row 1:** A7 (V), A7 (VI), D7 (V), G7 (V), G7 (VI), C7 (V)
- Row 2:** C7 (V), F7 (VI), F7 (V), Bb7 (IV)
- Row 3:** A9 (V), D9 (IV), D9 (V), G9 (IV), G9 (V), G9 (VI), C9 (V)
- Row 4:** C9 (V), C9 (V), F9 (V), Bb9 (V)
- Row 5:** A13 (V), D13 (III), D13 (V), G13 (V), C13 (V), F13 (V), F13 (VI)
- Row 6:** A11 (V), D11 (V), G11 (V)
- Row 7:** C11 (V), F11 (V), F11 (VI), Bb11 (IV)

## 2. Minor 7th Type Chords

Blackened dots are essential chord tones, circles are optional chord tones.

The image displays 28 guitar chord diagrams for minor 7th type chords, organized into 8 rows. Each diagram shows a 6-string guitar fretboard with black dots for essential chord tones and white circles for optional chord tones.

- Row 1:** Am7 V (4 diagrams), Dm7 V (6 diagrams)
- Row 2:** Gm7 V (4 diagrams), Cm7 V (4 diagrams), Fm7 IV (1 diagram), Fm7 VI (1 diagram)
- Row 3:** Fm7 V (1 diagram), Fm7 VI (1 diagram), Fm7 V (1 diagram), Bbm7 IV (1 diagram)
- Row 4:** Am9 V (5 diagrams), Dm9 V (2 diagrams), Dm9 VI (2 diagrams), Gm9 VI (1 diagram)
- Row 5:** Gm9 V (2 diagrams), Gm9 V (2 diagrams), Cm9 IV (1 diagram), Cm9 VI (2 diagrams), Fm9 IV (1 diagram), Fm9 VI (1 diagram)
- Row 6:** Am11 V (4 diagrams), Dm11 V (6 diagrams)
- Row 7:** Gm11 V (5 diagrams), Cm11 V (3 diagrams)
- Row 8:** Fm11 VI (1 diagram), Fm11 V (1 diagram), Fm11 VI (1 diagram)
- Row 9:** Am13 V (1 diagram), Dm13 IV (1 diagram), Dm13 V (1 diagram), Gm13 V (1 diagram), Cm13 V (1 diagram), Fm13 VI (1 diagram)

### 3. Major 7th ( $\Delta 7$ ) Type Chords

Blackened dots are essential chord tones, circles are optional chord tones.

The diagram displays the following chord voicings:

- Row 1:  $A\Delta 7 IV$ ,  $A\Delta 7 V$ ,  $D\Delta 7 IV$ ,  $D\Delta 7 V$ ,  $D\Delta 7 VI$ ,  $G\Delta 7 V$
- Row 2:  $C\Delta 7 V$ ,  $F\Delta 7 V$
- Row 3:  $A\Delta 9 V$ ,  $A\Delta 9 VI$ ,  $D\Delta 9 IV$ ,  $D\Delta 9 V$ ,  $G\Delta 9 IV$ ,  $G\Delta 9 V$ ,  $C\Delta 9 V$ ,  $F\Delta 9 V$
- Row 4:  $F\Delta 9 III$ ,  $Bb\Delta 9 V$ ,  $A\Delta 7\#11 IV$ ,  $D\Delta 7\#11 V$ ,  $G\Delta 7\#11 V$ ,  $F\Delta 7\#11 V$
- Row 5:  $A\Delta 9\#11 V$ ,  $D\Delta 9\#11 V$ ,  $G\Delta 9\#11 V$ ,  $C\Delta 9\#11 V$ ,  $C\Delta 9\#11 V$ ,  $Bb\Delta 9\#11 V$
- Row 6:  $A\Delta 7b5 IV$ ,  $A\Delta 7b5 V$ ,  $A\Delta 7b5 VI$ ,  $D\Delta 7b5 IV$ ,  $D\Delta 7b5 V$ ,  $G\Delta 7b5 V$
- Row 7:  $G\Delta 7b5 V$ ,  $C\Delta 7b5 IV$ ,  $C\Delta 7b5 V$ ,  $F\Delta 7b5 V$ ,  $F\Delta 7b5 VI$ ,  $A\Delta 13n11 IV$ ,  $A\Delta 13n11 V$ ,  $A\Delta 13\#11 IV$ ,  $A\Delta 13\#11 V$
- Row 8:  $D\Delta 13n11$  OR  $D\Delta 13\#11 VI$ ,  $C\Delta 13n11$  OR  $G\Delta 13\#11 IV$ ,  $C\Delta 13n11$  OR  $F\Delta 13\#11 V$ ,  $F\Delta 13\#11 V$ ,  $F\Delta 13\#11 V$ ,  $F\Delta 13\#11 V$ ,  $Bb\Delta 13\#11 V$ ,  $F\Delta 13\#11 V$

#### 4. Add 9 (9), Minor Add 9 (M/9), 6, M6 6/9 & M6/9 Chords.

Blackened dots are essential chord tones, circles are optional chord tones.

The diagram displays the following chords in order from top-left to bottom-right:

- Row 1: A/9 V, D/9 V, G/9 IV, G/9 V, C/9 V, F/9 V
- Row 2: F/9 V, Bb/9 V, Eb/9 V, Am/9 V, Dm/9 V
- Row 3: Gm/9 V, Cm/9 IV, Cm/9 V, Fm/9 V, Bbm/9 IV, Ebm/9 IV
- Row 4: A6 V, D6 V, G6 V, G6 IV, C6 V
- Row 5: F6 V, Bb6 V, Eb6 V, Am6 V
- Row 6: Am6 V, Dm6 V, Gm6 V, Cm6 V, Fm6 VI
- Row 7: A6/9 IV, A6/9 V, D6/9 IV, D6/9 V, G6/9 V
- Row 8: G6/9 V, C6/9 V, F6/9 V, Am6/9 V
- Row 9: Dm6/9 V, Gm6/9 V, Cm6/9 IV, Cm6/9 V, Fm6/9 IV, Bbm6/9 IV, Bbm6/9 V, Ebm6/9 V



## 5. Suspended Type Chords

Blackened dots are essential chord tones, circles are optional chord tones.

The image displays a collection of guitar chord diagrams for suspended chords, organized into eight rows. Each diagram shows a 6-string guitar fretboard with black dots representing essential chord tones and white circles representing optional chord tones. The chords are labeled as follows:

- Row 1: **Asus4V**, **Dsus4V**, **Gsus4V**, **Csus4V**, **Fsus4V**
- Row 2: **Asus2V**, **Dsus2V**, **Gsus2V**, **Csus2V**
- Row 3: **Fsus2V**, **Asus2/4V**, **Dsus2/4V**
- Row 4: **Gsus2/4V**, **Csus2/4V**, **Fsus2/4V**
- Row 5: **A7sus4V**, **D7sus4V**, **G7sus4V**
- Row 6: **C7sus4V**, **F7sus4V**
- Row 7: **A7sus2V**, **D7sus2V**, **G7sus2V**, **C7sus2V**
- Row 8: **A11V**, **D11V**, **G11V**, **C11V**

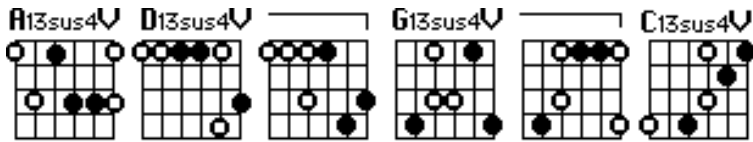

"STACKED" PERFECT FOURTHS

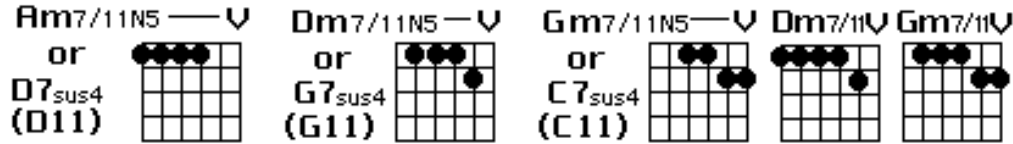

"STACKED" PERFECT FIFTHS

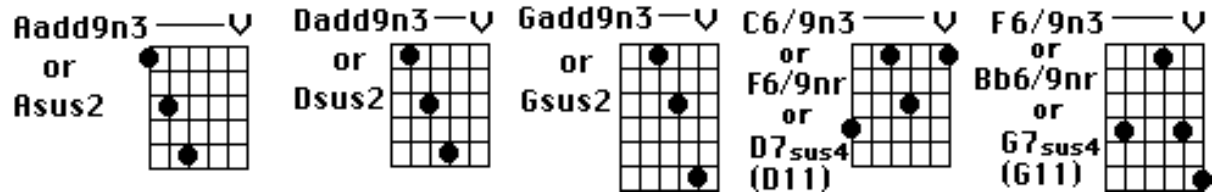

6. Whole Tone Chords: 7#5, 7b5, 9#5, 9b5.

Blackened dots are essential chord tones, circles are optional chord tones.

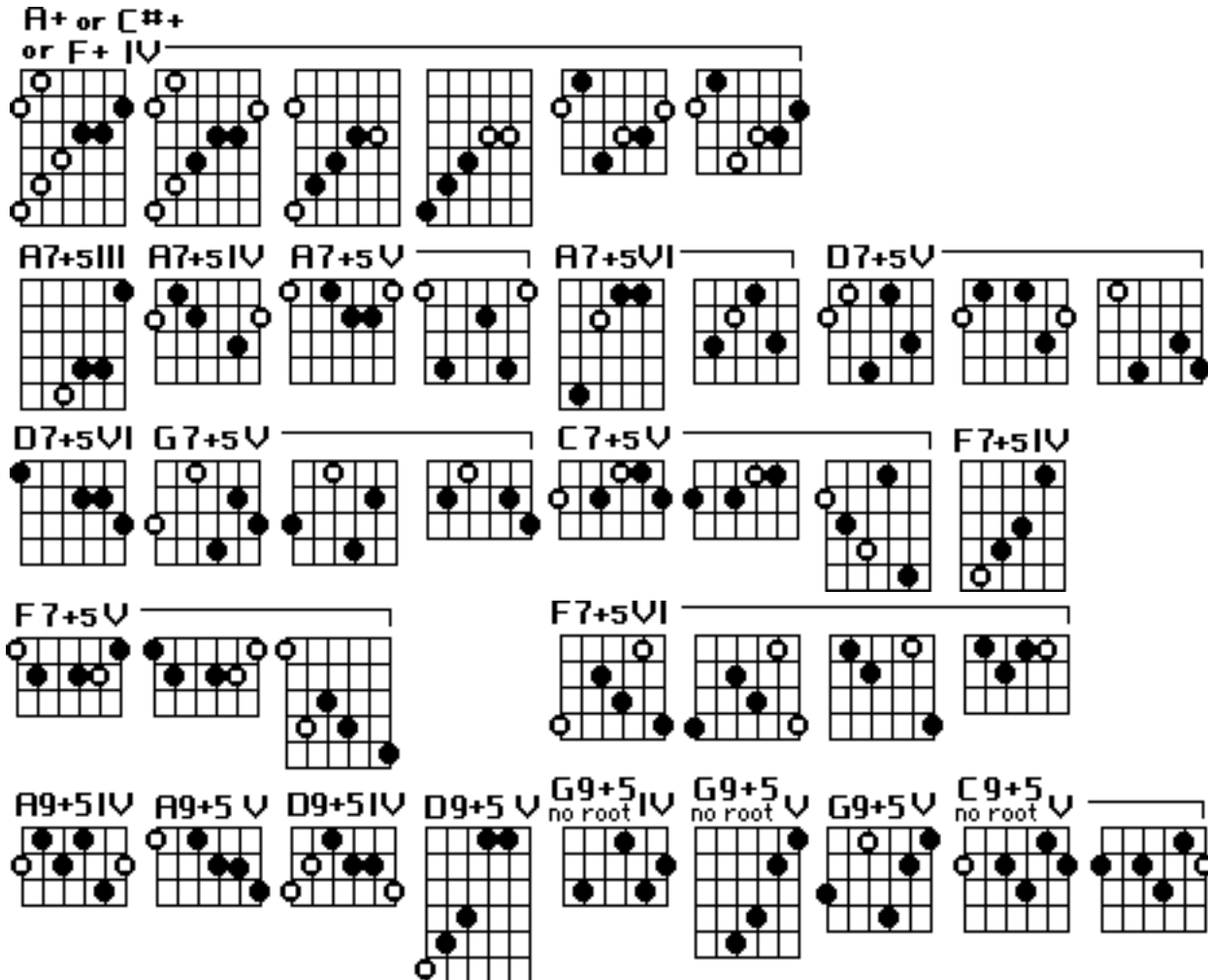

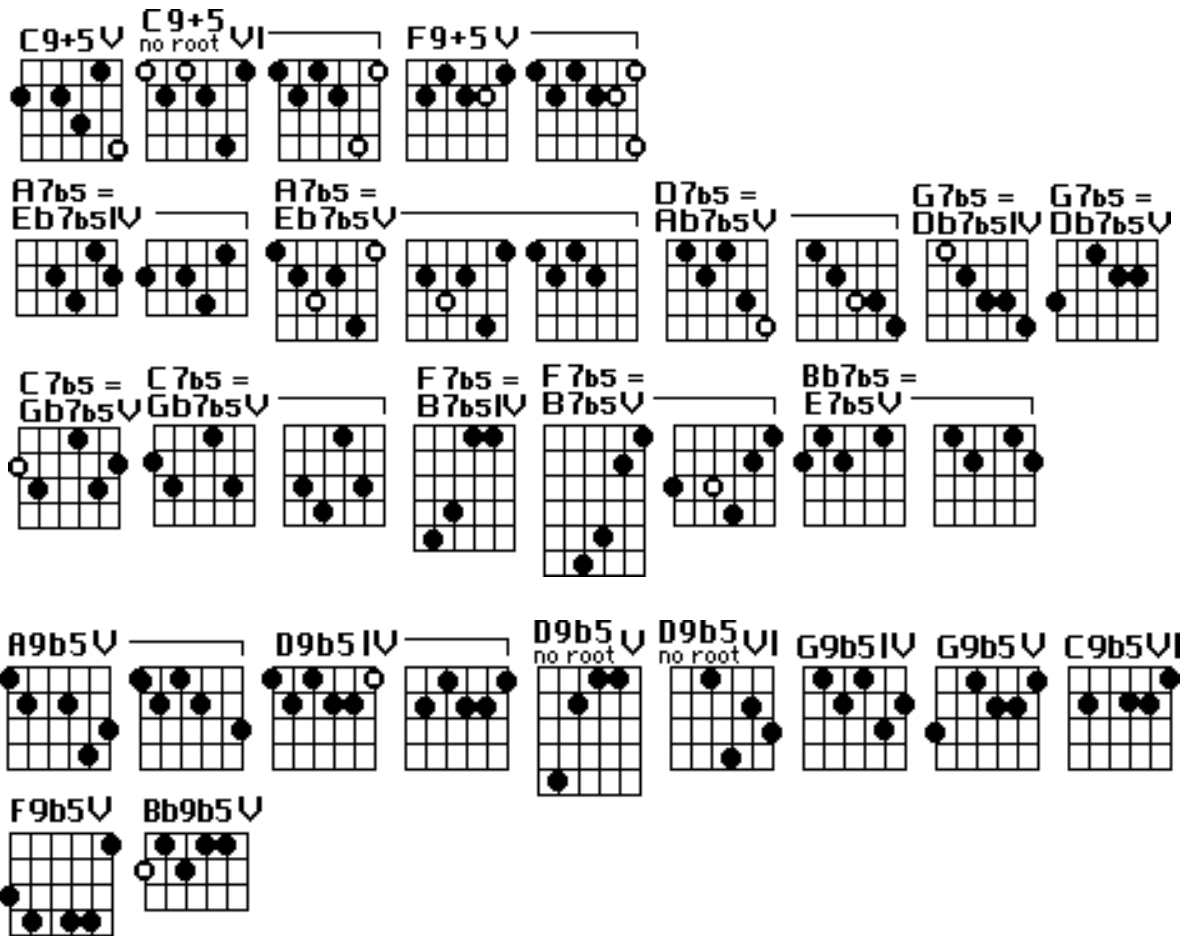

### 7. Other Altered Dominant Chords

*Blackened dots are essential chord tones, circles are optional chord tones.*

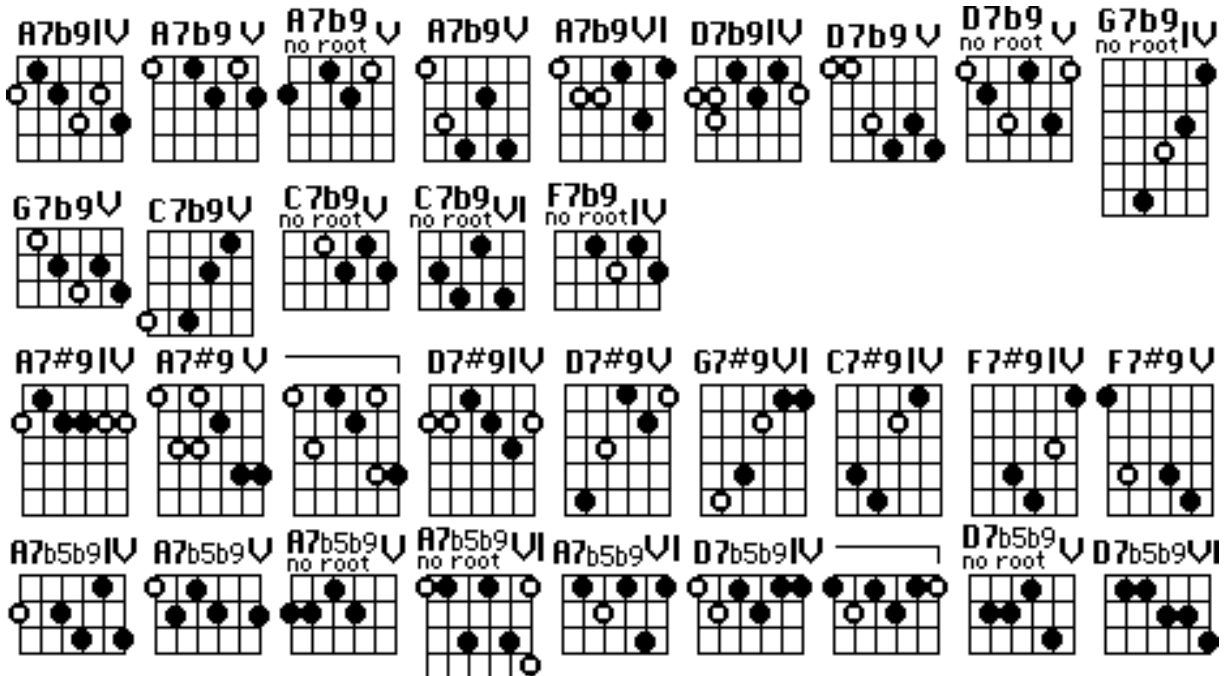

**A7<sup>b5</sup>9<sup>U</sup>** **D7<sup>b5</sup>9<sup>IU</sup>** **G7<sup>b5</sup>9<sup>VI</sup>** **C7<sup>b5</sup>9<sup>VI</sup>** **F7<sup>b5</sup>9<sup>IU</sup>** **Bb7<sup>b5</sup>9<sup>U</sup>**

**A7<sup>#5</sup>b9<sup>U</sup>** **D7<sup>#5</sup>b9<sup>IU</sup>** **G7<sup>#5</sup>b9<sup>IU</sup>** **C7<sup>#5</sup>b9<sup>no root</sup>** **C7<sup>#5</sup>b9<sup>VI</sup>** **F7<sup>#5</sup>b9<sup>no root</sup>**

**A7<sup>#5</sup>9<sup>IU</sup>** **A7<sup>#5</sup>9<sup>U</sup>** **D7<sup>#5</sup>9<sup>IU</sup>** **G7<sup>#5</sup>9<sup>VI</sup>** **C7<sup>#5</sup>9<sup>IU</sup>** **C7<sup>#5</sup>9<sup>no root</sup>** **F7<sup>#5</sup>9<sup>U</sup>** **Bb7<sup>#5</sup>9<sup>U</sup>**

**A7<sup>#11</sup>IU** **D7<sup>#11</sup>IU** **G7<sup>#11</sup>no root** **C7<sup>#11</sup>U** **F7<sup>#11</sup>VI**

**D9<sup>#11</sup>no root IU** **G9<sup>#11</sup>U**

NOTE: 7<sup>b5</sup> may be used as a substitute for 7<sup>#11</sup>.

**A13<sup>b5</sup>U** **D13<sup>b5</sup>U** **G13<sup>b5</sup>no root U** **C13<sup>b5</sup>U** **F13<sup>b5</sup>VI**

NOTE: 13<sup>b5</sup> may be used as a substitute for 13<sup>#11</sup>.

**A13<sup>b5</sup>9<sup>no root</sup>U** **D13<sup>b5</sup>9<sup>no root</sup>IU** **C13<sup>b5</sup>9<sup>no root</sup>U** **A13<sup>b5</sup>9<sup>no root</sup>U** **D13<sup>b5</sup>9<sup>no root</sup>IU** **F13<sup>b5</sup>9<sup>no root</sup>VI**

## 8. Diminished Type Chords

Blackened dots are essential chord tones, circles are optional chord tones.

**A<sup>o</sup>7, C<sup>o</sup>7, Eb<sup>o</sup>7 or Gb<sup>o</sup>7** **V**

**A<sup>o</sup>7, C<sup>o</sup>7, Eb<sup>o</sup>7 or Gb<sup>o</sup>7** **VI** **A<sup>o</sup>7, C<sup>o</sup>7, Eb<sup>o</sup>7 or Gb<sup>o</sup>7** **VII**

**Am7<sup>b5</sup>IU** **Am7<sup>b5</sup>U** **Dm7<sup>b5</sup>IU** **Dm7<sup>b5</sup>U** **Dm7<sup>b5</sup>no root U** **Gm7<sup>b5</sup>IU** **Gm7<sup>b5</sup>U** **Gm7<sup>b5</sup>VI**

**Gm7<sup>b5</sup>VI** **Cm7<sup>b5</sup>IU** **Cm7<sup>b5</sup>U** **Cm7<sup>b5</sup>VI** **Fm7<sup>b5</sup>IU** **Fm7<sup>b5</sup>VI**

### 9. Minor Major Seventh (Minor Natural Seventh) Chords

*Blackened dots are essential chord tones, circles are optional chord tones.*

<b>Am(ma7) IV</b>	<b>Am(ma7) V</b>	<b>Dm(ma7) V</b>	<b>Gm(ma7) V</b>	<b>Cm(ma7) IV</b>	<b>Cm(ma7) V</b>	<b>Fm(ma7)nr IV</b>
<b>Fm(ma7) V</b>	<b>Am9(ma7) V</b>	<b>Dm9(ma7) III</b>	<b>Gm9(ma7) V</b>	<b>Cm9(ma7) VI</b>		



# Chord. Inversion.



- **What Is Chord Inversion?**
- **Root Position**
- **First Inversion**
- **Second Inversion**
- **Third Inversion**

# What Is Inversion?

## HARMONY IN THIRDS

Before going into the specifics of chord inversion, you need to know the fundamentals of chord construction in a harmonic sense. The fundamental unit of harmony is the third. Chords are typically constructed with consecutive notes from a cycle of thirds. The cycle of thirds is shown below in numbers and in letters. If this is not familiar to you, review Chapter 12: Structural Chord Types.

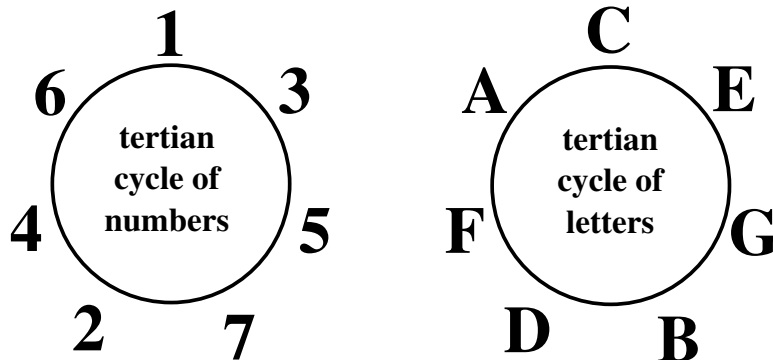

## CHANGING THE ORDER OF PITCH

The most notable tones of a chord are the usually the lowest and highest pitches. Most commonly, the lowest pitch in a chord is the note after which it is named and is called the chord root.

## Root Position

If the root of the chord is the lowest pitch, the chord is said to be in root position. When the root is not the lowest pitch, the chord is inverted. See the diagrams below.

## First Inversion

If the third of the chord is the lowest pitch, the chord is said to be in first inversion. If the chord is a suspended fourth, with the fourth as the lowest pitch, the chord is in first inversion. If the chord is a suspended second, the second as the lowest pitch would make it in first inversion. See the diagrams below.

## Second Inversion

If the fifth of the chord is the lowest pitch, the chord is said to be in second inversion. See the diagrams below.



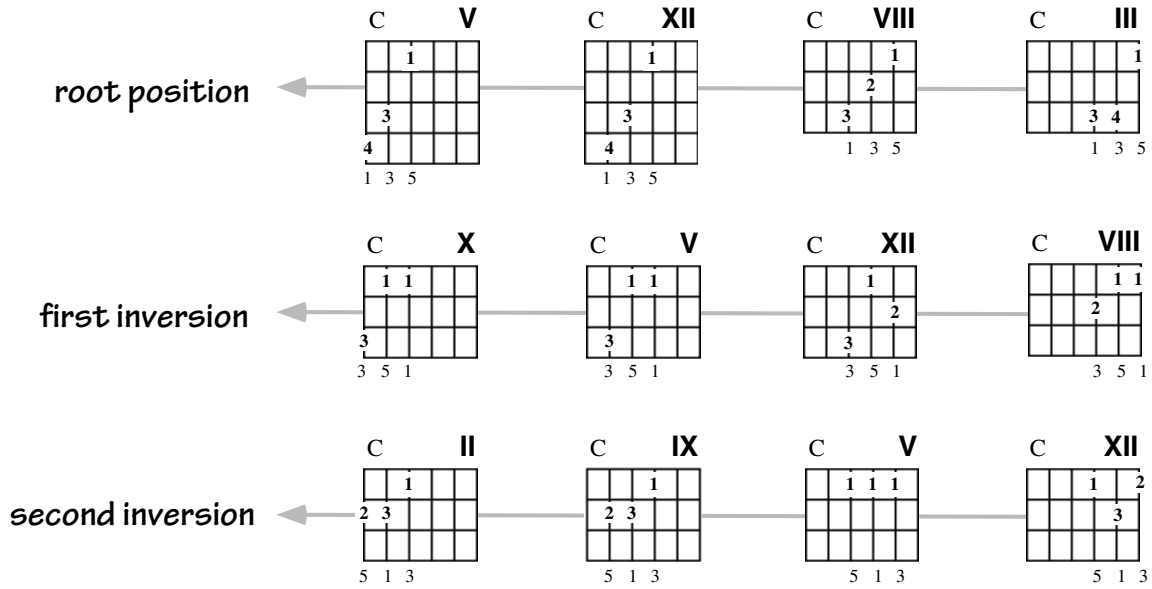

## Third Inversion

### SEVENTH AND SIXTH CHORDS

If the seventh or sixth of a chord is the lowest pitch, the chord is said to be in third inversion. The other inversions are numbered the same.

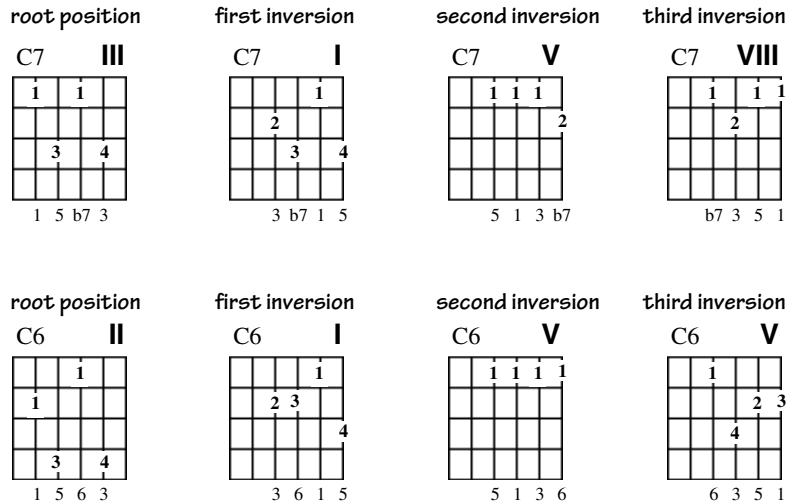

## SUSPENDED 2/4 CHORDS

Chords with a suspended second *and* fourth are not universally accepted. It is standard that the fifth in the bass makes a chord second inversion, but the suspended 2/4 chord presents a problem. It is debatable how they should be treated in regards to inversion. Should the second in the bass make it first inversion, or should the fourth. Probably the second, but if so, would the fourth in the bass make it second inversion or third inversion?

# Using The CD Rom



- **Search By Chord Name**
- **Search By Chord Grid**
- **Navigation And Keyboard Shortcuts**
- **Advanced Searches**

**grid search** 8 pos root **search by name** **column** **page**

subset (1) (1.5) (2) position

1 3 3 2 1 1

**column** **page**

C major VIII

1 5 1 3 5 1

pos root

1 Ab

2 A

3 A#

4 Bb

5 B

6 B#

7 Cb

8 C

9 C#

10 Db

11 D

12 D#

13 Eb

E

E#

Fb

F

F#

Gb

G

G#

**C major**

root chord type

types ma3 mi3 5

no root no fifth

ID 6-1

octave 641

family maj

serial no. 151351

major minor dim. majb5 aug. sus4

ma7 m7 m7b5 7 7b5 7#5 7sus4

ma9 m9 m9b5 9 9b5 9#5 9sus4

ma9#11 m11 m11b5 11n3 9#11 13sus4

ma13#11 m13 13 13#11 7b9#11 7b9sus4

6 m6 dim7 6/9#11 7#9#11 13b9sus4

6/9 m6/9 dim7/9 6/9b5 sus2

ma9/6 m9/6 13b9 9/6 9/6b5 9/6#11 9/6sus4

/9 m/9 7b9 7#9 7b5b9 7#5b9 7n3

ma7#11 m7/11 m7/11b5 7/#11 7b5#9 7#5#9 9n3

ma7/6 m7/6 7/6b9 7/6 7/6b5 7/6#11 7/6sus4

ma7b5 m(ma7) m(ma7)b5 7b5b9#9 7#5b9#9 ma7n3

ma9b5 m9(ma7) m9(ma7)b5 7b9/#9 7b5#5b9 7b5#5#9 ma9n3

ma7/6b5 m(ma7)/6 7b5#5 ma7sus4

ma7#5 m9(ma7)/6 9b5#5 7sus2

ma9#5 ma7/6#11 7/6b5b9 ma7sus2

13b5b9 13b5#9

©2001 Jim Gleason. All Rights Reserved.

## Search By Chord Name

- Click the “search by name” button. It is on the top center of the search view.
- Click a button for the chord root in the vertical column of letter buttons (Ab, A, A#, Bb, B, B#, C, etc.). Optionally, you can enter the chord’s letter name in the “root” field (no spaces, slashes or periods).
- Click a button for the chord type from the larger block of buttons (the top horizontal row begins “major”, “minor”, “dim.”). Optionally, you can enter the chord type in text.
- Option: type in a position (Arabic number). The position field is immediately to the right of the grid search button.
- Click on the “column” or “page” view button to the right of the “search by name” button. Do not click the “find” button, since it does not include some of the discrete criteria that the “search by name” button provides. Clicking the find button will usually give you more results than you want.
- The chord fingerings will be shown.

## Search By Chord Grid

- Click the “grid search” button. It is on the upper left of the search view.
- Type in a position number (Arabic). In this case, the position is not necessarily the same as the “strict vertical position” referred to in Chapter 8. This position number represents the lowest-numbered fret being fingered.
- Click the notes on grid. Only click one note per string. At least one note must be on the top fret.
- Click on the “column” or “page” view button between the grids. I prefer the page view.
- The chord fingerings will be shown. If you are using the page view, there may be more than one page of results. If so, click the lower book page icon on the top left of the screen to advance to the next page or click the upper book page icon to revert to the previous page.

## Navigation And Keyboard Shortcuts

### The Vertical Control Area

Clicking on the show/hide button on the lower left of all screens (shown below) hides or shows the vertical control area on the left.



The viewing mode is shown just to the right of the show/hide icon. The view modes are “browse”, “find”, and “preview”. During a search, the view mode button will say “find”. When you have clicked “column”, it will say “browse”. When you have clicked “page”, it will say “preview”. When the vertical control area is in view, the following is possible:

- In the page view there may be more than one page of results. If so, click the lower book page icon on the top left of the screen to advance to the next page or click the upper book page icon to revert to the previous page.

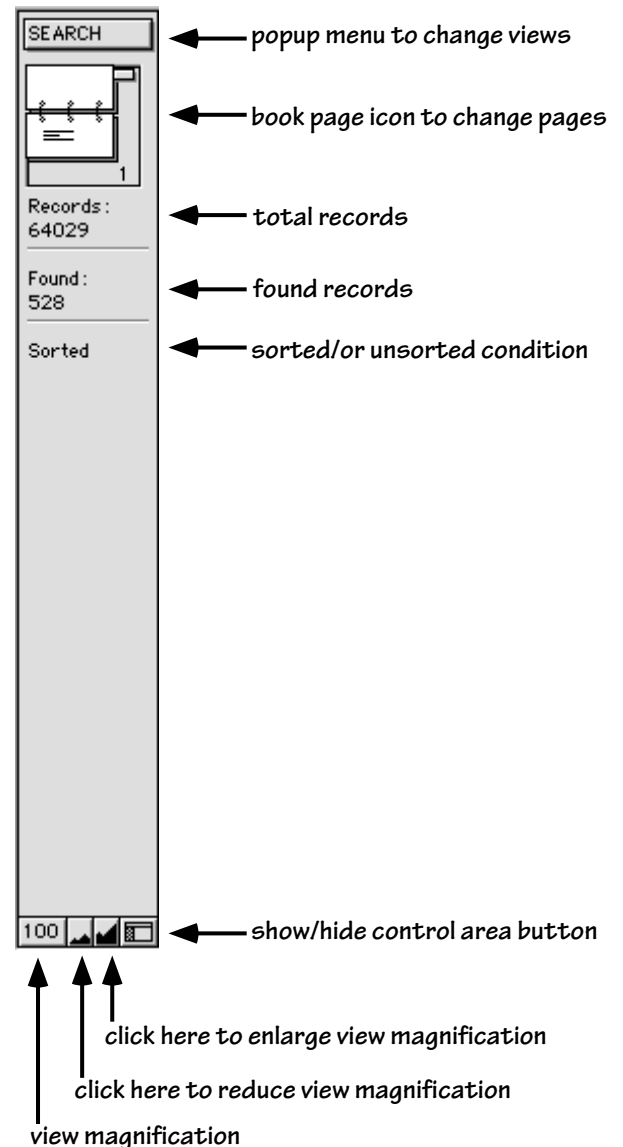

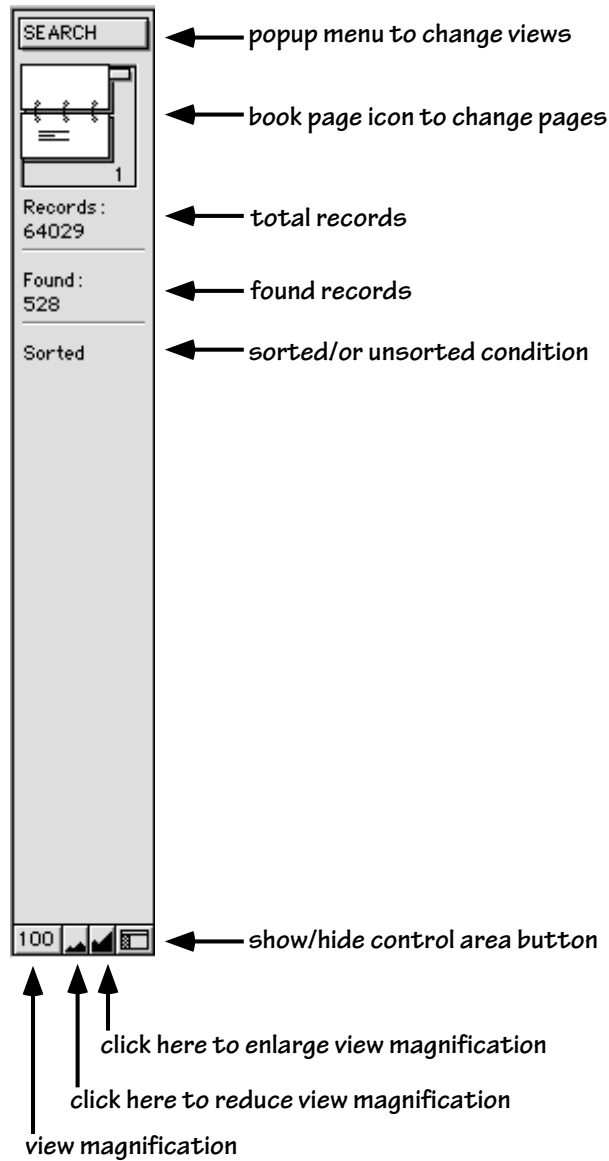

## Keyboard Shortcuts

action	Mac OS shortcut	Windows shortcut
show search view	command+1	control+1
show column view	command+2	control+2
show page view	command+2	control+2
browse (column view)	command+B	control+B
find (advanced user)	command+F	control+F
preview (change column to page)	command+U	control+U
print	command+P	control+P

# Advanced Searches

## Grid Search By Subset

- Click the “subset” button. It is below the grid search button.
- Follow the second through last steps in “Search By Chord Grid” at the beginning of this chapter.

## What Is A Guitar Chord Serial Number?

A guitar chord serial number identifies the chord with a formula number for each string, in order from sixth string to first string. If a string has no note on it, the number “0” is used for that string. No spaces are used between the formula numbers for each string. Here are a few examples.

<p>serial number: 151351</p> <p>C VIII</p> <p>1 5 1 3 5 1</p>	<p>serial number: 030b2b5b7</p> <p>C7b5b9nr VI</p> <p>3 b2 b5 b7</p>	<p>serial number: 0b73610</p> <p>C13 I</p> <p>b7 3 6 1</p>
---	--	--

In a guitar chord serial number, each tone of the chord is expressed with a formula number. If you don't know what a chord formula is, please review Chapter 6. The formula numbers are expressed with one digit numbers. An eleventh would be indicated as a fourth. A thirteenth would be indicated as a sixth. Remember, any string that is not to be played must be represented with a zero (0). No spaces are entered between characters.

In the C major chord (VIII position) above, the serial number is straightforward. Each number represents a string in order from sixth to first string: 151351. In the C7b5b9nr chord (“nr” means “no root”), a zero must be entered for the sixth and fourth strings, so the serial number is 030b2b5b7. The C13 chord must be represented with zeros for the sixth and first strings, so the serial number is 0b73610.

## Specify A Position

When conducting a search by grid, chord name or subset, you can specify a position by typing in the position field just to the right of the grid search button. Or, enter the position by clicking on any button in the column of Arabic numbers (1, 2, 3, 4, 5, etc.). You can specify a range of positions by entering one number, two periods (“.”), then another number. If you do a search for a single position by clicking the “find” button on the vertical control area (visible only in “search” view), you should enter the number, click the “=” button (explained below), then click the “find” button. Using the find button is generally not recommended, since any entry fields usually need to be specified with the “=” button after entry. Use the grid search, text search or subset buttons instead.

## How To Search For A Chord By Serial Number

Click on the “search by name” button or select “find” in the “mode” menu (command+F for Mac, control+F for Windows). Enter the desired serial number in the serial number box, located on the upper right of the search screen. Click a page button, column button, or type return.





# Figure Out Any Chord Fingering

- **The Goal Is To Not Need The CD Rom**
- **The Procedure**

## The Goal Is To Not Need The CD Rom

Who needs over 64,000 chords? Most guitarists can do fine with two or three hundred chord fingerings memorized for quick recall. However, in particular arrangements you may need any of the 64,000 to accommodate a chord melody or harmonization with some other instrument part. The important thing is *to be able to figure out all of the options for any chord.*

### The Procedure

The steps below will give you an awareness of the possible chords for any given area of the fretboard.

- To be prepared to construct any chord, you must have a thorough knowledge of the material covered in this book, including octave shapes, chord formulas, memorization of common fingerings (especially summary chords in appendix B), and essential chord tones.
- Choose the area on the fretboard in which you want to fret the chord. Usually, this is determined by a combination of the range of pitch, the tone produced by the guitar in that area of the fretboard and practicality of fingering.
- Determine the octave shape for the chord root in the area of the fretboard you have chosen.
- Chose a minimal set of essential chord tones.
- Consider options of notes that can be included with the essential chord tones, including those omitted in determining the essential tones and doubling any of the essential tones. First consider the options on the smallest two or three strings. You may have anywhere from one to around ten possibilities so far.
- Consider the possibilities derived so far as being a set of chords. Then consider that set with the additional of any notes and combinations of notes that can be added on the largest three strings. There may be any where from one to around ten possibilities for notes on the largest three strings. In many cases, this will provide well over twenty possibilities.
- Tend to use larger intervals in the low range of pitch (on the larger strings) and smaller intervals on the smaller strings.
- Avoid voicing the seventh in the low range. Ninths, elevenths and thirteenths should almost never be voiced in the low range. Exceptions would include playing in ensembles where much lower instruments, such as bass violin are playing in a much lower range of pitch, making your lower range relatively not so low.

# Appendices

<b>A COMMON CHORDS.....</b>	<b>165</b>
<b>B EXERCISES.....</b>	<b>181</b>
<b>C SUMMARY CHORDS.....</b>	<b>193</b>
<b>D TWO NOTE CHORDS.....</b>	<b>197</b>
<b>E SCALE TONE CHORDS.....</b>	<b>203</b>
<b>F CHORDS BY TYPE.....</b>	<b>211</b>



# Common Chord Fingerings



- **First Chord Reference Charts**
- **Three Note Chords**
- **Essential Blues Chords**
- **Jazz Chords**

# First Chord Reference Charts

## FIRST 19 CHORDS

**A** | **C** | **D** | **E** | **F** | **G** | **G** | **Am** | **Dm** | **Em** | **A7** | **B7** | **C7** | **D7** | **E7**

The chords below are movable.  
Each chord is named after its circled note.

**F** | **Fm** | **Bm** | **B** | **G** | **Gm** | **Cm** | **C** | **A** | **Am** | **Dm** | **D**

## FIRST 35 CHORDS

A   	A7   	A7   	Am   	Am7   	
B    	B7    	B7   	B9   	Bm    	Bm7    
C   	C7   				
D   	D    	D7   	D/F#   	Dm   	Dm7   
E   	E7   	E7   	Em   	Em7   	Em7   
F   	F   	F7   	Fm   	Fm7   	
G   	G   	G7   	G/B   	G9nr    	

# FIRST 53 CHORDS

A I A II A7 I A7 I Am I Am/C II Am7 I Am7 I

B II B7 II B7 I B9 I Bm II Bm7 I Bm7 II

C I C7 I Cm7 I C dim7 II

either chord tone can be the root

D I D II D7 I D/F# I Dm I Dm I Dm/F I Dm7 I

E I E7 I E7 I Em I Em7 I Em7 I Em7 II E dim7 II

either chord tone can be the root

F I F I F7 I Fm I Fm I Fm7 I Fm7 I

G I G I G7 I G/B I Gm/Bb I Gdim7 II G9nr II Gm III Gm(ma7) III Gm7 III C9 no root III

either chord tone can be the root



# FIRST 78 CHORDS

A I A II A III A/C# II A7 I A7 I Ama7 I Ama7 I Am I Am/C II Am7 I Am7 I

B II B7 II B7 I B7 II B9 I B7#9 I Bma7 II Bm II Bm7 I Bm7 II Bm7b5 II Bm7b5 I

C I C7 I Cma7 I Cm7 I Cm7 I Cm7 I Cm9 I C aug. I C dim7 II

either chord tone can be the root

D I D II Dma7 II D7 I D/F# I Dma7 I Dm I Dm I Dm/F I Dm7 I Dm7b5 I

E I E7 I E7 I E7 II Ema7 II Em I Em7 I Em7 I Em7 II Em7b5 II E dim7 II

either chord tone can be the root

F I F I F7 I F7 II Fma7 I Fma7 I Fm I Fm I Fm7 I Fm7 I F aug. I

either chord tone can be the root

G I G I G/B I G7 I G7 I G7 I Gma7 II Gm/Bb I Gm7/Bb I Gm7/Bb I Gdim7 II G9nr II

either chord tone can be the root

# FIRST 93 CHORDS

The diagram displays 93 guitar chord shapes, each with a name, a Roman numeral, and a fretboard diagram showing fingerings. The chords are arranged in rows:

- A Chords:** A I, A II, A II, A/C# II, A7 I, A7 I, Ama7 I, Ama7 I, Am I, Am/C II, Am7 I, Am7 I, A sus.4 I, A7sus.4 I
- B Chords:** B II, B7 II, B7 I, B7 II, B9 I, B7#9 I, Bma7 II, Bm II, Bm7 I, Bm7 II, Bm7b5 II, Bm7b5 I, B sus.4 II, B7sus.4 II
- C Chords:** C I, C7 I, Cma7 I, Cm7 I, Cm7 I, Cm7 I, Cm9 I, C sus.4 I, C7sus.4 I
- D Chords:** D I, D II, Dma7 II, D7 I, D/F# I, Dma7 I, Dm I, Dm I, Dm/F I, Dm7 I, Dm7b5 I, D sus.4 I, D7sus.4 I
- E Chords:** E I, E7 I, E7 I, E7 II, Ema7 II, Em I, Em7 I, Em7 I, Em7 II, Em7b5 II, E sus.4 I, E7 sus.4 I, E7 sus.4 I
- F Chords:** F I, F I, F7 I, F7 I, Fma7 I, Fma7 I, Fm I, Fm I, Fm7 I, Fm7 I, F sus.4 I, F7 sus.4 I
- G Chords:** G I, G I, G/B I, G7 I, G7 I, G7 I, Gma7 II, Gm/Bb I, Gm7/Bb I, Gm7b5/Bb I, G9nr II, G sus.4 I, G7 sus.4 I

dim7      dim7      dim7      augmented      augmented

either chord tone can be the root      either chord tone can be the root      either chord tone can be the root      either chord tone can be the root      either chord tone can be the root

## COMMON CHORDS BY OCTAVE SHAPE

same octave shape down each column; same type across each row

	641 root	42 root	52 root	53 root	631 root		D/F#	G
major	E	D	C	A	G			
minor	Em	Dm	Cm	Am	Gm		Dm/F	
$\Delta 7$ major 7th								
7 dominant 7th								
m7								
m7b5								

**augmented**

any note can be root	any note can be root	any note can be root

**dim. 7**

any note can be root	any note can be root	any note can be root

# Three Note Chords

## INTRODUCTION TO THREE NOTE MAJOR CHORDS

### Three Note Close-Voiced Major Triads

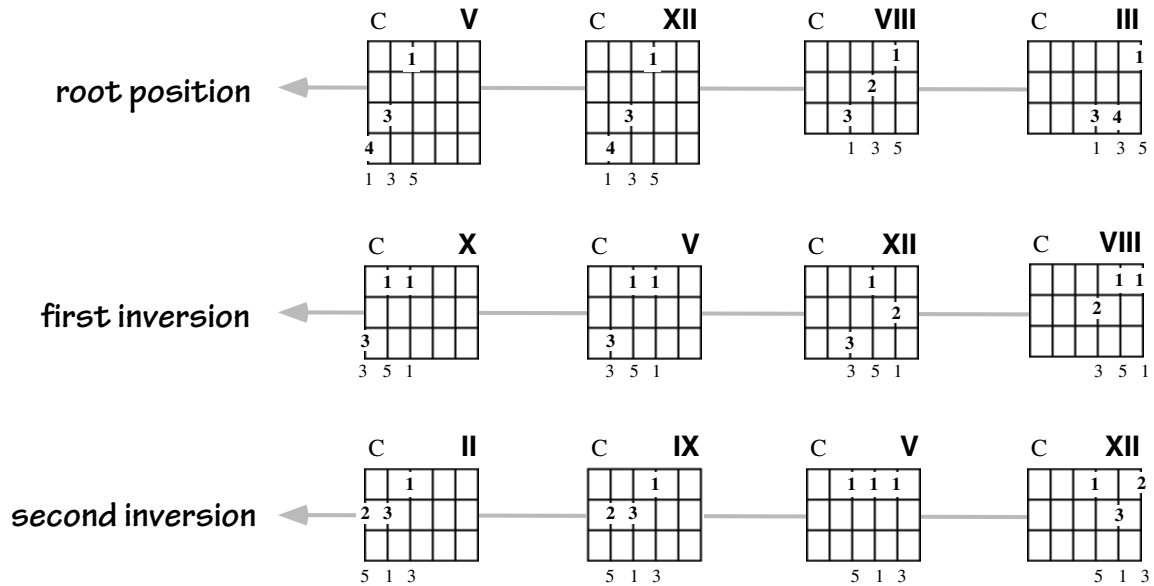

### Three Note Open-Voiced Major Triads

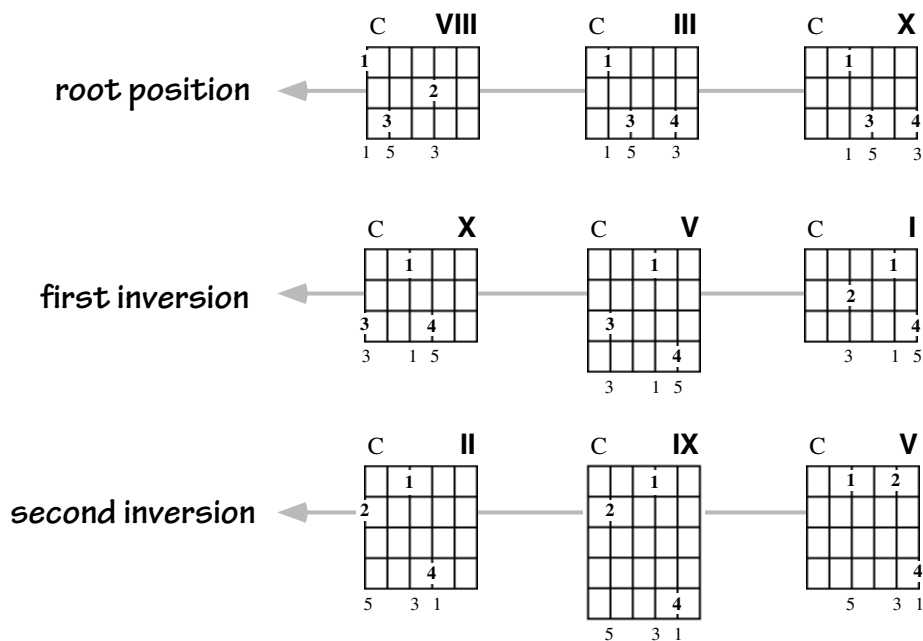

## THREE NOTE CLOSE-VOICED TRIADS

### Three Note Close-Voiced Major

root position

A <b>II</b>	A <b>IX</b>	A <b>V</b>	A <b>XII</b>
1 3 5	1 3 5	1 3 5	1 3 5

third in bass

A <b>VII</b>	A <b>II</b>	A <b>IX</b>	A <b>V</b>
3 5 1	3 5 1	3 5 1	3 5 1

fifth in bass

A <b>XI</b>	A <b>VI</b>	A <b>II</b>	A <b>IX</b>
5 1 3	5 1 3	5 1 3	5 1 3

### Three Note Close-Voiced Minor

root position

Am <b>II</b>	Am <b>IX</b>	Am <b>V</b>	Am <b>XII</b>
1 b3 5	1 b3 5	1 b3 5	1 b3 5

~  
third in bass

Am <b>VII</b>	Am <b>II</b>	Am <b>IX</b>	Am <b>V</b>
b3 5 1	b3 5 1	b3 5 1	b3 5 1

fifth in bass

Am <b>X</b>	Am <b>V</b>	Am <b>I</b>	Am <b>VIII</b>
5 1 b3	5 1 b3	5 1 b3	5 1 b3

## THREE NOTE OPEN-VOICED TRIADS

major, root position	minor, root position	diminished, root position
major, first inversion	minor, first inversion	diminished, first inversion
major, second inversion	minor, second inversion	diminished, first inversion

# Essential Blues Chords

	641 root	42 root	52 root	53 root	631 root	additional fingerings		
<b>7</b> 1 3 5 b7 dominant 7th								
<b>9</b> 1 3 5 b7 9 (=2) (nr = m7b5)								
<b>13</b> 1 3 5 b7 9 11 13 (9=2, 11=4, 13=6) dominant 13th								
<b>6</b> 1 3 5 6 major 6th								

<b>6th</b>	<b>9n3n5</b>	<b>6th</b>	<b>9n3n5</b>	<b>6th</b>	<b>9nm5</b>	<b>I6</b>	<b>IV9 and V9</b>	
<b>6th</b>	<b>9n3n5</b>	<b>6th</b>	<b>9n3n5</b>	<b>6th</b>	<b>9nm5</b>	<b>I6</b>	<b>IV9 and V9</b>	
<b>6th</b>	<b>9n3n5</b>	<b>6th</b>	<b>9n3n5</b>	<b>6th</b>	<b>9nm5</b>	<b>I9</b>	<b>IV9 and V9</b>	
<b>6th</b>	<b>9n3n5</b>	<b>6th</b>	<b>9n3n5</b>	<b>6th</b>	<b>9nm5</b>	<b>I9</b>	<b>IV9 and V9</b>	
<b>6th</b>	<b>9n3n5</b>	<b>6th</b>	<b>9n3n5</b>	<b>6th</b>	<b>9nm5</b>	<b>I7</b>	<b>IV9</b>	<b>V7</b>
<b>6th</b>	<b>9n3n5</b>	<b>6th</b>	<b>9n3n5</b>	<b>6th</b>	<b>9nm5</b>	<b>I9</b>	<b>IV9</b>	<b>V9</b>

# Jazz Chords

## Jazz Chords

practice in succession

<b>ORIGIN</b> E	<b>major</b> 1 3 5	<b>7 (dom 7)</b> 1 3 5 b7	<b>6</b> 1 3 5 6	<b>m9 (minor 9)</b> 1 2 b3 5 b7	<b>7b5</b> 1 3 #5 b7	<b>minor</b> 1 b3 5	<b>m(ma7)</b> 1 b3 5 7	<b>m7</b> 1 b3 5 b7	<b>m6</b> 1 b3 5 6	<b><sup>o</sup>7 (dim 7) *</b> 1 b3 b5 6	<b>m7b5</b> 1 b3 b5 b7
<b>G</b>	Gmaj7 III	G7 III	G6 II	Gm9nr III	G7b5 II	Gm III	Gm(ma7) III	Gm7 III	Gm6 II	G <sup>o</sup> 7 dim7 II	Gm7b5 II
<b>F</b>	F III	Fmaj7 III	F6 III	Fm9nr III	F7b5 III	Fm III	Fm(ma7) III	Fm7 III	Fm6 III	F <sup>o</sup> 7 dim7 III	Fm7b5 III
<b>E♭</b>	E♭ III	E♭maj7 III	E♭6 IV	E♭m9nr III	E♭7b5 II	E♭m III	E♭m(ma7) III	E♭m7 III	E♭m6 IV	E♭ <sup>o</sup> 7 dim7 IV	E♭m7b5 IV
<b>C</b>	C III	Cmaj7 III	C6 II	Cm9nr III	C7b5 III	Cm III	Cm(ma7) III	Cm7 III	Cm6 II	C <sup>o</sup> 7 dim7 II	Cm7b5 III
<b>B♭</b>	B♭ III	B♭maj7 III	B♭6 III	B♭m9nr III	B♭7b5 II	B♭m III	B♭m(ma7) III	B♭m7 III	B♭m6 II	B♭ <sup>o</sup> 7 dim7 II	B♭m7b5 II
<b>F</b>	F III	Fmaj7 III	F6 III	Fm9nr III	F7b5 III	Fm III	Fm(ma7) III	Fm7 III	Fm6 III	F <sup>o</sup> 7 dim7 III	Fm7b5 III
<b>A</b>	A III	Amaj7 III	A6 III	A9nr III	A7b5 III	A III	A(ma7) III	A7 III	A6 III	A <sup>o</sup> 7 dim7 III	A7b5 III
<b>G</b>	G III	Gmaj7 III	G6 II	Gm9nr III	G7b5 II	Gm III	Gm(ma7) III	Gm7 III	Gm6 II	G <sup>o</sup> 7 dim7 II	Gm7b5 II

practice in succession

<b>augmented</b> 1 3 #5	<b>7#9</b> (1) #2 3 (5) b7	<b>m(ma7)</b> 1 b3 5 7	<b>m7</b> 1 b3 5 b7	<b>m6</b> 1 b3 5 6	<b><sup>o</sup>7 (dim 7) *</b> 1 b3 b5 6
<b>G</b>	G7#9 III	Gm(ma7) III	Gm7 III	Gm6 II	G <sup>o</sup> 7 dim7 II
<b>F</b>	F7#9 III	Fm(ma7) III	Fm7 III	Fm6 III	F <sup>o</sup> 7 dim7 III
<b>E♭</b>	E♭7#9 III	E♭m(ma7) III	E♭m7 III	E♭m6 IV	E♭ <sup>o</sup> 7 dim7 IV
<b>C</b>	C7#9 III	Cm(ma7) III	Cm7 III	Cm6 II	C <sup>o</sup> 7 dim7 II
<b>B♭</b>	B♭7#9 III	B♭m(ma7) III	B♭m7 III	B♭m6 II	B♭ <sup>o</sup> 7 dim7 II
<b>F</b>	F7#9 III	Fm(ma7) III	Fm7 III	Fm6 III	F <sup>o</sup> 7 dim7 III
<b>A</b>	A7#9 III	A(ma7) III	A7 III	A6 III	A <sup>o</sup> 7 dim7 III
<b>G</b>	G7#9 III	Gm(ma7) III	Gm7 III	Gm6 II	G <sup>o</sup> 7 dim7 II

Essential chord tones are the third, the seventh, the seventh (if involved) and any note mentioned in the chord name.  
 augmented = "+", = aug. = major #5 = 1 3 #5  
<sup>o</sup>7 = diminished seventh = 1 b3 b5 6 (bb7)  
 97 = m7b5 = half diminished = 1 b3 b5 b7  
 Δ7 = major 7 = maj 7 = M7 = 1 3 5 7  
 "7" = minor 7 = m7 = mīn7 = 1 b3 5 b7  
 "alt" = any combination of #5, b5, #9, b9 that sounds appropriate  
 min(ma7) = m(ma7) = m ( 47 ) = minor, major seventh = 1 b3 5 7

\* any note of a diminished seventh chord (<sup>o</sup>7) can be the root



practice in succession

ORIGIN	major 135	maj 7 1357	7 (dom 7) - 1 3 5 b7	6 1 3 5 6	
<p>E I</p> <p>1 5 1 3 5 1</p>	<p>C VIII</p> <p>1 5 1 3 5 1</p>	<p>Cma7 VIII</p> <p>1 7 3 5</p>	<p>C7 VIII</p> <p>1 b7 3 5</p>	<p>C6 VII</p> <p>1 6 3 5</p>	<p>C aug. VI</p> <p>1 #5 3 #5</p>
<p>D I</p> <p>1 5 1 3</p>	<p>C X</p> <p>1 5 1 3</p>	<p>Cma7 X</p> <p>1 5 7 3</p>	<p>C7 X</p> <p>1 5 b7 3</p>	<p>C6 X</p> <p>1 5 6 3</p>	<p>C aug. X</p> <p>1 3 #5 3</p>
<p>C I</p> <p>1 3 5 1</p>	<p>C XII</p> <p>1 3 5 1</p>	<p>Cma7 XII</p> <p>1 3 5 7</p>	<p>C7 XIII</p> <p>1 3 b7 1</p>	<p>C6 XIII</p> <p>1 3 6 1</p>	<p>C aug. XIII</p> <p>1 3 #5 1</p>
<p>A I</p> <p>1 5 1 3</p>	<p>C III</p> <p>1 5 1 3</p>	<p>Cma7 III</p> <p>1 5 7 3</p>	<p>C7 III</p> <p>1 3 b7 3 5</p>	<p>C6 II</p> <p>1 5 6 3</p>	<p>C aug. III</p> <p>1 #5 1 3</p>
<p>G I</p> <p>5 1 3 1</p>	<p>C V</p> <p>5 1 3 1</p>	<p>Cma7 V</p> <p>5 1 3 7</p>	<p>C7 V</p> <p>5 1 3 b7</p>	<p>C6 V</p> <p>5 1 3 6</p>	<p>C aug. IV</p> <p>#5 1 3 #5</p>
<p>additional fingerings</p>	<p>C X</p> <p>3 1 5 1</p>		<p>C7 VIII</p> <p>1 5 b7 3 5 1</p>		

practice in succession

minor 1 b3 5	m(ma7) 1 b3 5 7	m7 1 b3 5 b7	m6 1 b3 5 6	°7 (dim 7)* 1 b3 b5 6	m7b5 1 b3 b5 b7
Cm <b>VIII</b>  1 5 1 b3 5 1	Cm(ma7) <b>VIII</b>  1 5 7 b3 5 1	Cm7 <b>VIII</b>  1 5 b7 b3 5 1	Cm6 <b>VII</b>  1 6 b3 5 1	C dim7 <b>VII</b>  1 6 b3 b5	Cm7b5 <b>VII</b>  1 b7 b3 b5
Cm <b>X</b>  1 5 1 b3	Cm(ma7) <b>X</b>  1 5 7 b3	Cm7 <b>X</b>  1 5 b7 b3	Cm6 <b>X</b>  1 5 6 b3	C dim7 <b>X</b>  1 b5 6 b3	Cm7b5 <b>X</b>  1 b5 b7 b3
Cm <b>XII</b>  b3 5 1	Cm(ma7) <b>XII</b>  b3 5 7	Cm7 <b>I</b>  1 b3 b7 1	Cm6 <b>I</b>  1 b3 6 1	C dim7 <b>I</b>  b3 6 1 b5	Cm7b5 <b>I</b>  b3 b7 1 b5
Cm <b>III</b>  1 5 1 b3 5	Cm(ma7) <b>III</b>  1 5 7 b3	Cm7 <b>III</b>  1 5 b7 b3 5	Cm6 <b>II</b>  1 5 6 b3	C dim7 <b>II</b>  1 b5 6 b3	Cm7b5 <b>III</b>  1 b5 b7 b3
Cm <b>V</b>  5 b3 5 1	Cm(ma7) <b>V</b>  5 b3 5 7	Cm7 <b>IV</b>  5 1 b3 b7	Cm6 <b>IV</b>  5 1 b3 6	C dim7 <b>IV</b>  5 1 b3 6	Cm7b5 <b>IV</b>  b5 1 b3 b7
Cm <b>VIII</b>  1 b3 5 1	Cm(ma7) <b>VIII</b>  7 b3 5 1	Cm7 <b>VIII</b>  b7 b3 5 1	Cm6 <b>VII=</b>  6 b3 5 1	Cdim7 <b>VII</b>  6 b3 b5 1	Cdim7 <b>VII</b>  b7 b3 b5 1

\*any note of a diminished 7 chord can be the root

<p>9 (dom 9) 1 2 3 5 b7</p> <p>C9nr <b>VII</b></p> <p>3 b7 2 5</p>	<p>13 (1) (2) 3 (5) 6 b7</p> <p>C13 <b>VIII</b></p> <p>1 b7 3 6</p>	<p>7b5 1 3 #5 b7</p> <p>C7b5 <b>VII</b></p> <p>1 b7 3 b5</p>	<p>7#5 1 3 #5 b7</p> <p>C7#5 <b>VIII</b></p> <p>1 b7 3 #5</p>	<p>7 b9 1 b2 3 5 b7</p> <p>C7b9 <b>VIII</b></p> <p>b7 3 5 b2</p>	<p>7#9 (1) #2 3 (5) b7</p> <p>C7#9 <b>VIII</b></p> <p>1 5 3 b7 #2</p>	<p>m9 (minor 9) 1 2 b3 5 b7</p> <p>Cm9nr <b>VIII</b></p> <p>b7 b3 5 2</p>
<p>C9 <b>IX</b></p> <p>1 3 b7 2</p>	<p>C13 nr <b>IX</b></p> <p>1 3 b7 2</p>	<p>C7b5 <b>X</b></p> <p>1 b5 b7 3</p>	<p>C7#5 <b>X</b></p> <p>1 #5 b7 3</p>	<p>C7b9 <b>IX</b></p> <p>1 3 b7 b2</p>	<p>C7#9 <b>IX</b></p> <p>3 5 b7 b3</p>	<p>Cm9nr <b>X</b></p> <p>b3 5 b7 2</p>
<p>C9 <b>XIV</b></p> <p>1 3 b7 2 5</p>	<p>C13 <b>XIII</b></p> <p>b7 3 6 1</p>	<p>C7b5 <b>XI</b></p> <p>1 3 b5 b7</p>	<p>C7#5 <b>I</b></p> <p>b7 3 #5 1</p>	<p>C7b9 <b>I</b></p> <p>1 3 b7 b2 5</p>	<p>C7#9 <b>II</b></p> <p>1 3 b7 b3</p>	<p>Cm9 <b>XIII</b></p> <p>1 b3 b7 2 5</p>
<p>C9nr <b>III</b></p> <p>3 5 b7 2 5</p>	<p>C13 <b>II</b></p> <p>1 3 b7 2 6</p>	<p>C7b5 <b>III</b></p> <p>1 b5 b7 3</p>	<p>C7#5 <b>III</b></p> <p>1 b7 3 #5</p>	<p>C7b9 <b>II</b></p> <p>1 3 b7 b2</p>	<p>C7#9 nr <b>II</b></p> <p>1 3 b7 b3</p>	<p>Cm9nr <b>III</b></p> <p>b3 5 b7 2 5</p>
<p>C9nr <b>V</b></p> <p>5 2 3 b7</p>	<p>C13 <b>V</b></p> <p>1 b7 2 3 6</p>	<p>C7b5 <b>V</b></p> <p>3 b7 1 b5</p>	<p>C7#5 <b>V</b></p> <p>#5 1 3 b7</p>	<p>C7b9nr <b>V</b></p> <p>5 b2 3 b7</p>	<p>C7#9 <b>V</b></p> <p>1 3 b7 3 5</p>	<p>Cm9nr <b>V</b></p> <p>b3 2 5 b7</p>
<p>C9nr <b>VIII</b></p> <p>b7 3 5 2</p>	<p>The <b>essential chord tones</b> are the third, the seventh (if involved) and any note mentioned in the chord name.</p> <p>augmented = "+" = aug. = major #5 = 1 3 #5      Δ7 = major 7 = maj 7 = M7 = 1 3 5 7</p> <p>°7 = diminished seventh = 1 b3 b5 6 (bb7)      "-7" = minor 7 = m7 = min7 = 1 b3 5 b7</p> <p>Ø7 = m7b5 = half diminished = 1 b3 b5 b7      "alt" = combinations of #5, b5, #9, b9 that sound well</p> <p>min(ma7) = m(ma7) = m ( 7 ) = minor, major seventh = 1 b3 5 7</p>					



# Exercises

- **Major Scale And Arpeggio Exercises**
- **30 Most Important Seventh Chords Exercise**

## MAJOR SCALE AND MAJOR ARPEGGIO EXERCISES

These exercises summarize the most practical major arpeggios when they are combined in melodic phrases with major scale fingerings in the same key (C major arpeggio with C major scale, for example).

### Fingering 1

1 2 4 1 2 4 1 2 4 1 2 4 2 4 1 2 4 2 1 1 2 3 3 4 1  
 ↓ ↑ ↓ ↓ ↑ ↓ ↓ ↑ ↓ ↓ ↑ ↓ ↓ ↑ ↓ ↑ ↓ ↑ ↑ ↑ ↑ ↑ ↓

T 3/4  
 A 4  
 B 8 10 12 8 10 12 9 10 12 9 10 12 10 12 8 10 12 10 8 8 9 10 10 12 8

1 2 4 1 2 4 1 2 4 1 2 4 2 4 1 2 4 2 1 1 2 3 3 4 1  
 ↓ ↑ ↓ ↓ ↑ ↓ ↓ ↑ ↓ ↓ ↑ ↓ ↓ ↑ ↓ ↑ ↓ ↑ ↑ ↑ ↑ ↑ ↓

T 4/4  
 A 4  
 B 8 10 12 8 10 12 9 10 12 9 10 12 10 12 8 10 12 10 8 8 9 10 10 12 8

1 4 3 3 2 1 1 2 4 2 1 4 2 4 2 1 4 2 1 4 2 1  
 ↑ ↓ ↓ ↓ ↓ ↓ ↓ ↑ ↓ ↑ ↓ ↑ ↓ ↑ ↓ ↑ ↓ ↑ ↓ ↑ ↓ ↑

T 3/4  
 A 4  
 B 8 12 10 10 9 8 8 10 12 10 8 12 10 12 10 9 12 10 9 12 10 8 12 10 8

1 4 3 3 2 1 1 2 4 2 1 4 2 4 2 1 4 2 1 4 2 1  
 ↑ ↓ ↓ ↓ ↓ ↓ ↓ ↑ ↓ ↑ ↓ ↑ ↓ ↑ ↓ ↑ ↓ ↑ ↓ ↑ ↓ ↑

T 4/4  
 A 4  
 B 8 12 10 10 9 8 8 10 12 10 8 12 10 12 10 9 12 10 9 12 10 8 12 10 8

## Fingering 2

1 3 4 1 3 4 1 1 3 4 1 3 1 2 4 1 4 1 2 1 3 1 1 3 1

↓ ↑ ↓ ↓ ↑ ↓ ↓ ↑ ↓ ↑ ↓ ↑ ↓ ↑ ↓ ↑ ↓ ↑ ↓ ↑ ↓ ↑ ↓

T 3  
A 4  
B 4

10 12 13 10 12 14 10 12 14 15 12 14 12 13 15 12 15 12 13 12 14 10 10 12 10

1 3 4 1 3 4 1 1 3 4 1 3 1 2 4 1 4 1 2 1 3 1 1 3 1

↓ ↑ ↓ ↓ ↑ ↓ ↓ ↑ ↓ ↑ ↓ ↑ ↓ ↑ ↓ ↑ ↓ ↑ ↓ ↑ ↓

T 4  
A 4  
B 4

10 12 13 10 12 14 10 12 14 15 12 14 12 13 15 12 15 12 13 12 14 10 10 12 10

1 3 1 1 3 1 2 1 4 2 1 4 2 1 3 1 4 3 1 1 4 3 1 3 1

↓ ↑ ↓ ↓ ↑ ↓ ↓ ↓ ↑ ↓ ↑ ↑ ↓ ↑ ↓ ↑ ↓ ↑ ↓ ↑ ↓ ↑ ↑ ↓

T 3  
A 4  
B 4

10 12 10 10 14 12 13 12 15 13 12 15 13 12 14 12 15 14 12 10 14 12 10 12 10

1 3 1 1 3 1 2 1 4 2 1 4 2 1 3 1 4 3 1 1 4 3 1 3 1

↓ ↑ ↓ ↓ ↑ ↓ ↓ ↓ ↑ ↓ ↑ ↑ ↓ ↑ ↓ ↑ ↓ ↑ ↓ ↑ ↓ ↑ ↑ ↓

T 4  
A 4  
B 4

10 12 10 10 14 12 13 12 15 13 12 15 13 12 14 12 15 14 12 10 14 12 10 12 10

### Fingering 3

4 1 2 4 1 3 4 1 3 4 1 3 1 2 4 1 4 1 2 1 3 4 4 1 4  
 ↓ ↑ ↓ ↑ ↓ ↑ ↓ ↓ ↑ ↓ ↓ ↑ ↓ ↑ ↑ ↑ ↑ ↓ ↓

T 3/4  
 A 4  
 B 15 12 13 15 12 14 15 12 14 15 12 14 12 13 15 12 15 12 13 12 14 15 15 12 15

4 1 2 4 1 3 4 1 3 4 1 3 1 2 4 1 4 1 2 1 3 4 4 1 4  
 ↓ ↑ ↓ ↑ ↑ ↓ ↓ ↑ ↓ ↓ ↑ ↓ ↑ ↓ ↑ ↑ ↑ ↑ ↓ ↓

T 4/4  
 A 4  
 B 15 12 13 15 12 14 15 12 14 15 12 14 12 13 15 12 15 12 13 12 14 15 15 12 15

4 1 4 4 3 1 2 1 4 2 1 4 2 1 3 1 4 3 1 4 3 1 4 1 4  
 ↓ ↑ ↓ ↓ ↓ ↓ ↓ ↓ ↑ ↓ ↑ ↑ ↓ ↑ ↑ ↓ ↑ ↑ ↓ ↑ ↑ ↓ ↓

T 3/4  
 A 4  
 B 15 12 15 15 14 12 13 12 15 13 12 15 13 12 14 12 15 14 12 15 14 12 15 12 15

4 1 4 4 3 1 2 1 4 2 1 4 2 1 3 1 4 3 1 4 3 1 4 1 4  
 ↓ ↑ ↓ ↓ ↓ ↓ ↓ ↓ ↑ ↓ ↑ ↑ ↓ ↑ ↑ ↓ ↑ ↑ ↓ ↑ ↑ ↓ ↓

T 4/4  
 A 4  
 B 15 12 15 15 14 12 13 12 15 13 12 15 13 12 14 12 15 14 12 15 14 12 15 12 15



### Fingering 4

2 2 4 1 2 4 1 2 4 1 3 4 1 3 4 1 1 3 4 1 3 3 3 1 2  
 ↑ ↑ ↓ ↓ ↑ ↓ ↓ ↑ ↓ ↓ ↑ ↓ ↓ ↑ ↑ ↑ ↓ ↑

T 3/4  
 A 3/4  
 B 3 3 5 2 3 5 2 3 5 2 4 5 3 5 6 3 5 7 8 3 5 5 5 2 3

2 2 4 1 2 4 1 2 4 1 3 4 1 3 4 1 1 3 4 1 3 3 3 1 2  
 ↑ ↑ ↓ ↓ ↑ ↓ ↓ ↑ ↓ ↓ ↑ ↓ ↓ ↑ ↑ ↑ ↓ ↑

T 4/4  
 A 4/4  
 B 3 3 5 2 3 5 2 3 5 2 4 5 3 5 6 3 5 7 8 8 5 5 5 2 3

2 1 3 3 3 1 4 3 1 1 4 3 1 3 2 1 4 2 1 4 2 1 4 2 2  
 ↓ ↓ ↑ ↓ ↓ ↓ ↑ ↓ ↑ ↓ ↑ ↓ ↑ ↑ ↓ ↑ ↑ ↓ ↑ ↑ ↓ ↓

T 3/4  
 A 3/4  
 B 3 2 5 5 5 3 8 7 5 3 6 5 3 5 4 2 5 3 2 5 3 2 5 3 3

2 1 3 3 3 1 4 3 1 1 4 3 1 3 2 1 4 2 1 4 2 1 4 2 2  
 ↓ ↓ ↑ ↓ ↓ ↓ ↑ ↓ ↑ ↓ ↑ ↓ ↑ ↑ ↓ ↑ ↑ ↓ ↑ ↑ ↓ ↓

T 4/4  
 A 4/4  
 B 3 2 5 5 5 3 8 7 5 3 6 5 3 5 4 2 5 3 2 5 3 2 5 3 3

## Fingering 5

1 1 2 4 1 2 4 1 2 4 1 2 4 1 2 4 1 1 1 3 1  
 ↓ ↑ ↓ ↑ ↓ ↑ ↓ ↓ ↑ ↓ ↓ ↑ ↓ ↓ ↑ ↓ ↓ ↑ ↑ ↑ ↑ ↑ ↓

T 3/4  
 A 3/4  
 B 3/4  
 3 3 5 7 3 5 7 3 5 7 4 5 7 5 6 8 5 7 8 3 5 5 5 7 3

1 1 2 4 1 2 4 1 2 4 1 2 4 1 3 4 4 1 1 1 3 1  
 ↓ ↑ ↓ ↑ ↓ ↑ ↓ ↓ ↑ ↓ ↓ ↑ ↓ ↓ ↑ ↓ ↓ ↑ ↓ ↓ ↑ ↑ ↑ ↑ ↑ ↓

T 4/4  
 A 4/4  
 B 4/4  
 3 3 5 7 3 5 7 3 5 7 4 5 7 5 6 8 5 7 8 8 5 5 5 7 3

1 3 1 1 1 4 4 3 1 4 2 1 4 2 1 4 2 1 4 2 1 1  
 ↓ ↑ ↓ ↓ ↓ ↑ ↓ ↑ ↓ ↑ ↓ ↑ ↑ ↓ ↑ ↑ ↓ ↑ ↑ ↓ ↑ ↓

T 3/4  
 A 3/4  
 B 3/4  
 3 7 5 5 5 8 8 7 5 8 6 5 7 5 4 7 5 3 7 5 3 7 5 3 3

1 3 1 1 1 4 4 3 1 4 2 1 4 2 1 4 2 1 4 2 1 1  
 ↓ ↑ ↓ ↓ ↓ ↑ ↓ ↑ ↓ ↑ ↓ ↑ ↑ ↓ ↑ ↑ ↓ ↑ ↑ ↓ ↑ ↓

T 4/4  
 A 4/4  
 B 4/4  
 3 7 5 5 5 8 8 7 5 8 6 5 7 5 4 7 5 3 7 5 3 7 5 3 3

### Fingering 6

3/4

4 1 1 3 4 1 3 4 1 3 4 1 3 1 2 4 1 3 4 4 1 1 1 3 4  
 ↓ ↑ ↓ ↑ ↓ ↓ ↑ ↓ ↓ ↑ ↓ ↓ ↑ ↓ ↑ ↓ ↑ ↓ ↑ ↑ ↑ ↓

T 3/4  
 A 4/4  
 B 8 3 5 7 8 5 7 8 5 7 9 5 7 5 6 8 5 7 8 8 5 5 5 7 3

4/4

4 1 1 3 4 1 3 4 1 3 4 1 3 1 2 4 1 3 4 4 1 1 1 3 4  
 ↓ ↑ ↓ ↑ ↓ ↓ ↑ ↓ ↓ ↑ ↓ ↓ ↑ ↓ ↑ ↓ ↑ ↓ ↑ ↑ ↑ ↓

T 4/4  
 A 4/4  
 B 8 3 5 7 8 5 7 8 5 7 9 5 7 5 6 8 5 7 8 8 5 5 5 7 3

3/4

4 3 1 1 1 4 4 3 1 4 2 1 3 1 4 3 1 4 3 1 4 3 1 1 4  
 ↑ ↓ ↓ ↓ ↓ ↑ ↓ ↑ ↓ ↑ ↓ ↑ ↑ ↓ ↑ ↑ ↓ ↑ ↑ ↓ ↑ ↓ ↑

T 3/4  
 A 4/4  
 B 8 7 5 5 5 8 8 7 5 8 6 5 7 5 9 7 5 8 7 5 8 7 5 3 8

4/4

4 3 1 1 1 4 4 3 1 4 2 1 3 1 4 3 1 4 3 1 4 3 1 1 4  
 ↑ ↓ ↓ ↓ ↓ ↑ ↓ ↑ ↓ ↑ ↓ ↑ ↑ ↓ ↑ ↑ ↓ ↑ ↑ ↓ ↑ ↓ ↑

T 4/4  
 A 4/4  
 B 8 7 5 5 5 8 8 7 5 8 6 5 7 5 9 7 5 8 7 5 8 7 5 3 8

### Fingering 7

2 4 1 2 4 1 2 3 1 2 3 1 3 4 1 3 4 3 1 1 2 3 3 1 2  
 ↑ ↓ ↓ ↑ ↓ ↓ ↑ ↓ ↓ ↑ ↓ ↓ ↑ ↓ ↑ ↓ ↑ ↑ ↑ ↓ ↑

T 3/4  
 A 4  
 B 8 10 7 8 10 7 9 10 7 9 10 8 10 12 8 10 12 10 8 8 9 10 10 7 8

2 4 1 2 4 1 2 3 1 2 3 1 3 4 1 3 4 3 1 1 2 3 3 1 2  
 ↑ ↓ ↓ ↑ ↓ ↓ ↑ ↓ ↓ ↑ ↓ ↓ ↑ ↓ ↑ ↓ ↑ ↑ ↑ ↓ ↑

T 4/4  
 A 4  
 B 8 10 7 8 10 7 9 10 7 9 10 8 10 12 8 10 12 10 8 8 9 10 10 7 8

2 1 3 3 2 1 1 3 4 3 1 4 3 1 3 2 1 3 2 1 4 2 1 4 2  
 ↓ ↓ ↑ ↓ ↓ ↓ ↓ ↑ ↓ ↑ ↓ ↑ ↓ ↑ ↓ ↑ ↓ ↑ ↓ ↑ ↓ ↑ ↓

T 3/4  
 A 4  
 B 8 7 10 10 9 8 8 10 12 10 8 12 10 8 10 9 7 10 9 7 10 8 7 10 8

2 1 3 3 2 1 1 3 4 3 1 4 3 1 3 2 1 3 2 1 4 2 1 4 2  
 ↓ ↓ ↑ ↓ ↓ ↓ ↓ ↑ ↓ ↑ ↓ ↑ ↓ ↑ ↓ ↑ ↓ ↑ ↓ ↑ ↓ ↑ ↓

T 4/4  
 A 4  
 B 8 7 10 10 9 8 8 10 12 10 8 12 10 8 10 9 7 10 9 7 10 8 7 10 8

# Five Basic Major And Minor Arpeggios Exercise

## Procedures For The Exercise

- Using the Five Basic Major And Minor Arpeggios page (the next page), memorize the five major barré chords and note their adjoining structure on the full fretboard major arpeggio diagram at the top right.
- Notice that each barré chord was made up by fingering an open-position major chord *without* the index finger, then using the index finger to barré. Four of the five fingerings use a six string barré (the D form chord in the column below the first position D chord does not).
- It is very important to memorize the relative location of the circled chord roots, which make up an octave shape in each chord and arpeggio. These five octave shapes make up a system that puts each scale, arpeggio, chord and melodic phrase in one of five categories in regard to the location of the chord root or tone center after which it is named.
- Each arpeggio is diagrammed twice. In the row labeled “major arpeggio”, each arpeggio is shown with formula numbers, comparing the notes in the arpeggio to a major scale on its root. Directly below each major arpeggio fingering (in the row labeled “finger numbers”) the finger numbers for your fretting hand are shown.
- After playing all five barré chords, play the arpeggio for each.
- To see the logic in the numbered chord tones in the arpeggio, play the major scale fingering for each, which is shown directly below in the row labeled “major scale”.
- Each major scale fingering is diagrammed twice. In the “major scale” row, each scale fingering is shown with numbered major scale tones. Directly below each major scale fingering (in the row labeled “finger numbers”) the finger numbers for your fretting hand are shown.

## Using What You Learned To Construct Major and Minor Arpeggios

- Identify the octave shape for the chord roots
- Play the barréd version of the major chord on the chord roots.
- Using a reference page with the seven “in-position” major scale fingerings, find the major scale fingering which has “1” in the same octave shape as your chord roots.
- Play the major scale and think the numbered scale tones.
- Play the complete major arpeggio, which is all the “1, 3, 5’s”. You will be adding one or two notes to the barréd chord fingering you played earlier.
- If you want a minor arpeggio, flat the thirds.

## FIVE BASIC MAJOR AND MINOR ARPEGGIOS

open position major chord

E I	D I	C I	A I	G I

octaves of F ("1" represents "F" the first note of the F major scale)

641, E form "F" notes I	42, D form "F" notes III	52, C form "F" notes VI	53, A form "F" notes VIII	631, G form "F" notes X

major chord	F I	F III	F V	F VIII	F X
major arpeggio					
finger numbers					

major scale					
finger numbers					

minor chord	Fm I	Fm III	Fm IV	Fm VIII	Fm X
minor arpeggio					
finger numbers					

major arpeggio

	E
	D
	C
	A
	G
	E

minor arpeggio

	E
	D
	C
	A
	G
	E

## 30 Most Important Seventh Chords Exercise

Use the procedure described below to test your self on the formulas of the thirty seventh chords shown below.

- Cover up the formula numbers below one row of diagrams on the next page.
- Memorize the root location for one of the major seventh chords at the far left. The root is the circled note.
- Using your knowledge of intervals, identify the formula numbers for the other tones in the chord. Peek at the numbers below the major seventh chord to confirm the formula numbers.
- Cover the formula numbers again.
- Finger the major seventh chord (ma7). Flat the seventh of the major seventh chord to produce the dominant seventh chord (7).
- Flat the third of the dominant seventh chord to produce the minor seventh chord (m7).
- Flat the fifth of the minor seventh chord to produce the minor seventh flat five chord (m7 $\flat$ 5)
- Flat the seventh again (making a double flat) to produce the diminished seventh chord (dim.7).

Repeat this procedure for each row.

### Thirty Most Important Seventh Chords

Fma7 <b>VIII</b>	F7 <b>VIII</b>	Fm7 <b>VIII</b>	Fm7b5 <b>VIII</b>	Fdim7 <b>VII</b>
① 2 3 4	① 1 3 4	① 1 2 3	① 2 3 4	② 1 3 4
1 5 7 3	1 5 b7 3	1 5 b7 b3	1 b5 b7 b3	1 b5 6 b3
Cma7 <b>IX</b>	C7 <b>IX</b>	Cm7 <b>VIII</b>	Cm7b5 <b>VIII</b>	Cdim7 <b>VIII</b>
1 2 ③ 4 5 1 3 7	1 2 ③ 4 5 1 3 b7	1 2 ③ 4 5 1 b3 b7	1 2 ③ 4 b5 1 b3 b7	1 2 ③ 4 b5 1 b3 6
Cma7 <b>VIII</b>	C7 <b>VIII</b>	Cm7 <b>VIII</b>	Cm7b5 <b>VII</b>	Cdim7 <b>VII</b>
① 2 3 4	① 2 3 4	① 3 3 3	② 1 3 4	② 1 1 3
1 7 3 5	1 b7 3 5	1 b7 b3 5	1 b7 b3 b5	1 6 b3 b5
Gma7 <b>VIII</b>	G7 <b>VIII</b>	Gm7 <b>VIII</b>	Gm7b5 <b>VIII</b>	Gdim7 <b>VIII</b>
① 2 3 4 5 3 7 1	1 ① 3 4 5 3 b7 1	1 ① 3 4 5 b3 b7 1	1 ① 2 4 b5 b3 b7 1	1 ① 2 3 b5 b3 6 1
Fma7 <b>III</b>	F7 <b>III</b>	Fm7 <b>III</b>	Fm7b5 <b>III</b>	Fdim7 <b>III</b>
① 3 3 3	① 2 3 4	① 2 3 4	① 3 3 3	① 2 3 4
1 5 7 3	1 5 b7 3	1 5 b7 b3	1 b5 b7 b3	1 b5 6 b3
Cma7 <b>V</b>	C7 <b>V</b>	Cm7 <b>IV</b>	Cm7b5 <b>IV</b>	Cdim7 <b>IV</b>
1 ① 1 3	1 ① 1 2	1 2 ③ 4	1 1 ② 4	1 2 ③ 4
5 1 3 7	5 1 3 b7	5 1 b3 b7	b5 1 b3 b7	b5 1 b3 6



# Summary Chords

- **Major**
- **Minor**
- **Major Seventh**
- **Dominant Seventh**
- **Minor Seventh**
- **Minor Seventh Flat Five**
- **Diminished Seventh**

### MAJOR SUMMARY CHORDS

A <b>V</b>	A <b>VI</b>	A <b>VII</b>	A <b>VII</b>	A <b>VII</b>	A <b>IX</b>	A <b>IX</b>
A <b>IX</b>	A <b>XI</b>	A <b>XII</b>	A <b>II</b>	A <b>II</b>	A <b>II</b>	

### MINOR SUMMARY CHORDS

Am <b>V</b>	Am <b>V</b>	Am <b>VII</b>	Am <b>VII</b>	Am <b>VII</b>	Am <b>VIII</b>	Am <b>VIII</b>
Am <b>IX</b>	Am <b>IX</b>	Am <b>X</b>	Am <b>XII</b>	Am <b>II</b>	Am <b>II</b>	Am <b>II</b>

### MAJOR SEVENTH SUMMARY CHORDS

Ama7 <b>V</b>	Ama7 <b>V</b>	Ama7 <b>VI</b>	Ama7 <b>VII</b>	Ama7 <b>VII</b>	Ama7 <b>IX</b>	Ama7 <b>X</b>	Ama7 <b>X</b>
Ama7 <b>X</b>	Ama7 <b>XI</b>	Ama7 <b>XI</b>	Ama7 <b>XII</b>	Ama7 <b>XII</b>	Ama7 <b>II</b>	Ama7 <b>IV</b>	

## DOMINANT SEVENTH SUMMARY CHORDS

<b>A7 V</b>	<b>A7 VI</b>	<b>A7 VII</b>	<b>A7 VII</b>	<b>A7 IX</b>	<b>A7 X</b>	<b>A7 X</b>	<b>A7 X</b>
<b>A7 XI</b>	<b>A7 XI</b>	<b>A7 XII</b>	<b>A7 XII</b>	<b>A7 II</b>	<b>A7 II</b>	<b>A7 II</b>	<b>A7 IV</b>

## MINOR SEVENTH SUMMARY CHORDS

<b>Am7 V</b>	<b>Am7 V</b>	<b>Am7 VII</b>	<b>Am7 VII</b>	<b>Am7 VIII</b>	<b>Am7 X</b>	<b>Am7 X</b>	<b>Am7 X</b>
<b>Am X</b>	<b>Am7 X</b>	<b>Am7 X</b>	<b>Am7 XII</b>	<b>Am7 I</b>	<b>Am7 I</b>	<b>Am7 II</b>	<b>Am7 III</b>

## MINOR SEVENTH FLAT FIVE SUMMARY CHORDS

<b>Am7b5 V</b>	<b>Am7b5 V</b>	<b>Am7b5 VII</b>	<b>Am7b5 VII</b>	<b>Am7b5 VIII</b>	<b>Am7b5 X</b>	<b>Am7b5 X</b>
<b>Am7 XII</b>	<b>Am7 XII</b>	<b>Am7 I</b>	<b>Am7 I</b>	<b>Am7 II</b>	<b>Am7 III</b>	<b>Am7 IV</b>

## DIMINISHED SEVENTH SUMMARY CHORDS

A dim. 7 **V**

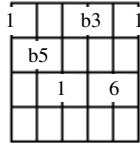

A dim. 7 **VII**

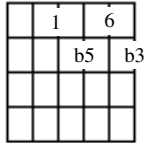

A dim. 7 **VII**

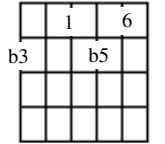

A dim. 7 **VIII**

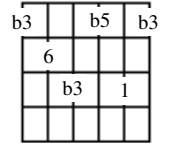

A dim. 7 **X**

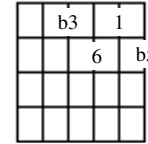

A dim. 7 **X**

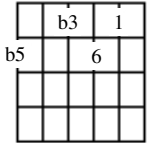

A dim. 7 **XI**

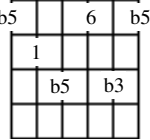

A dim. 7 **I**

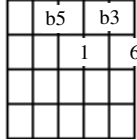

A dim. 7 **I**

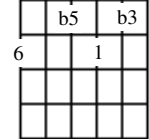

A dim. 7 **II**

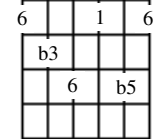

A dim. 7 **IV**

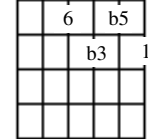

A dim. 7 **IV**

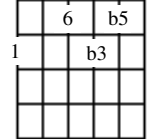

# Two-Note Chords

- **Major Scale Tone Fifths**
- **Major Scale Tone Fourths**
- **Major Scale Tone Thirds**
- **Major Scale Tone Sixths**

# Major Scale-Tone Fifths

Think of the lower-pitched note in each fifth as being the “chord root”. Inverted perfect fifths (P5) become perfect fourths (P4). Inverted augmented fourths (aug. 4) become diminished fifths (dim. 5).

G major scale

scale tones: 1 2 3 4 5 6 7 1 scale tones: 5 6 7 1 2 3 4 5  
scale tones: 1 2 3 4 5 6 7 1

T  
A  
B

3 5 7 8 10 12 14 15 3 5 7 10 12 14 15 17

C major scale

scale tones: 1 2 3 4 5 6 7 1 scale tones: 5 6 7 1 2 3 4 5  
scale tones: 1 2 3 4 5 6 7 1

T  
A  
B

3 5 7 8 10 12 14 15 3 5 7 10 12 14 15 17

E major scale

scale tones: 1 2 3 4 5 6 7 1 scale tones: 5 6 7 1 2 3 4 5  
scale tones: 1 2 3 4 5 6 7 1

T  
A  
B

2 4 6 7 9 11 13 14 4 6 8 9 11 13 14 16

A major scale

scale tones: 1 2 3 4 5 6 7 1 scale tones: 5 6 7 1 2 3 4 5  
scale tones: 1 2 3 4 5 6 7 1

T  
A  
B

2 4 6 7 9 11 13 14 5 7 9 10 12 14 15 17

D major scale

scale tones: 1 2 3 4 5 6 7 1 scale tones: 5 6 7 1 2 3 4 5  
scale tones: 1 2 3 4 5 6 7 1

T  
A  
B

3 5 7 8 10 12 14 15 5 7 9 10 12 14 15 17

# Major Scale-Tone Fourths

Think of the upper-pitched note in each fourth as being the “chord root”. Inverted perfect fourths (P4) become perfect fifths (P5). Inverted augmented fourths (aug. 4) become diminished fifths (dim. 5).

C major scale

1 2 3 4 5 6 7 1

P4 P4 P4 P4 P4 P4 aug. 4 P4

1 2 3 4 5 6 7 1

5 6 7 1 2 3 4 5

T  
A  
B 3 5 7 8 10 12 14 15

3 5 7 8 10 12 13 15

F major scale

1 2 3 4 5 6 7 1

P4 P4 P4 P4 P4 P4 aug. 4 P4

1 2 3 4 5 6 7 1

5 6 7 1 2 3 4 5

T  
A  
B 3 5 7 8 10 12 14 15

3 5 7 8 10 12 13 15

A major scale

1 2 3 4 5 6 7 1

P4 P4 P4 P4 P4 P4 aug. 4 P4

1 2 3 4 5 6 7 1

5 6 7 1 2 3 4 5

T  
A  
B 2 4 6 7 9 11 13 14

2 4 6 7 9 11 12 14

D major scale

1 2 3 4 5 6 7 1

P4 P4 P4 P4 P4 P4 aug. 4 P4

1 2 3 4 5 6 7 1

5 6 7 1 2 3 4 5

T  
A  
B 3 5 7 8 10 12 14 15

3 5 7 8 10 12 14 15

G major scale

1 2 3 4 5 6 7 1

P4 P4 P4 P4 P4 P4 aug. 4 P4

1 2 3 4 5 6 7 1

5 6 7 1 2 3 4 5

T  
A  
B 3 5 7 8 10 12 14 15

3 5 7 8 10 12 13 15

# Major Scale-Tone Thirds

Think of the lower-pitched note in each third as being the “chord root”. Inverted major thirds (M3) become minor sixths (m6). Inverted minor thirds (m3) become major sixths (M6).

G major scale

1 2 3 4 5 6 7 1 3 4 5 6 7 1 2 3

T  
A  
B 3 5 7 8 10 12 14 15 3 5 7 8 10 12 14 15

C major scale

1 2 3 4 5 6 7 1 3 4 5 6 7 1 2 3

T  
A  
B 3 5 7 8 10 12 14 15 3 5 7 8 10 12 14 15

E major scale

1 2 3 4 5 6 7 1 3 4 5 6 7 1 2 3

T  
A  
B 2 4 6 7 9 11 13 14 2 4 6 7 9 11 13 14

A major scale

1 2 3 4 5 6 7 1 3 4 5 6 7 1 2 3

T  
A  
B 2 4 6 7 9 11 13 14 2 4 6 7 9 11 13 14

D major scale

1 2 3 4 5 6 7 1 3 4 5 6 7 1 2 3

T  
A  
B 3 5 7 8 10 12 14 15 3 5 7 8 10 12 14 15



# Major Scale-Tone Sixths

Think of the upper-pitched note in each sixth as being the “chord root”. Inverted major sixths (M6) become minor thirds (m3). Inverted minor sixths (m6) become major thirds (M3).

E major scale

scale tones: 1 2 3 4 5 6 7 1 scale tones: 1 2 3 4 5 6 7 1  
 scale tones: 3 4 5 6 7 1 2 3

T																
A	2	4	6	7	9	11	13	14	2	4	6	7	9	11	13	14
B									4	5	7	9	11	12	14	16

A major scale

scale tones: 1 2 3 4 5 6 7 1 scale tones: 1 2 3 4 5 6 7 1  
 scale tones: 3 4 5 6 7 1 2 3

T																
A	2	4	6	7	9	11	13	14	2	4	6	7	9	11	13	14
B									4	5	7	9	11	12	14	16

D major scale

scale tones: 1 2 3 4 5 6 7 1 scale tones: 1 2 3 4 5 6 7 1  
 scale tones: 3 4 5 6 7 1 2 3

T	3	5	7	8	10	12	14	15	3	5	7	8	10	12	14	15
A									4	5	7	9	11	12	14	16
B																

F major scale

scale tones: 1 2 3 4 5 6 7 1 scale tones: 1 2 3 4 5 6 7 1  
 scale tones: 3 4 5 6 7 1 2 3

T	1	3	5	6	8	10	12	13	1	3	5	6	8	10	12	13
A									2	3	5	7	9	10	12	14
B																



# Scale-Tone Chords

- **Usuable Scale-Tone Chords**
- **Scale Tone Triad Pairs**
- **Scale Tone 9th, 11th and 13th Chords**
- **Scale Tone Altered Dominant Chords**
- **Scale Tone Add Tone Chords**

# Usuable Scale-Tone Chords

Each of the charts below lists all the practically usable chords that can be constructed on each step of a seven tone scale. Scale steps are numbered in Roman numerals across the top of the chart. The specific chord that would occur on any particular scale step using only tones of the scale is listed below the roman numeral and the chord type is indicated at the far left. The chord names in the left column (such as “triad” and “seventh”) indicate a general type of chord. The specific chord type that occurs on each scale step is shown beneath the respective roman numeral.

## Usuable Major Scale-Tone Chords

type	I	II	III	IV	V	VI	VII
triad	major	minor	minor	major	major	minor	diminished
seventh	ma7	m7	m7	ma7	7	m7	m7b5
ninth	ma9	m9	—	ma9	9	m9	—
eleventh	—	m11	—	ma9#11	11	m11	—
thirteenth	—	m13	—	ma13#11	13	—	—
11 no 3	—	11n3	—	—	11n3	11n3	—
13 no 11	13n11	m13n11	—	13n11	13n11	—	—
sixth	6	m6	—	6	6th	—	—
add 9	/9	m/9	—	/9	/9	m/9	—
6/9 (pentatonic)	6/9	m6/9	—	6/9	6/9	—	—
sus.4	sus.4	sus.4	sus.4	—	sus.4	sus.4	—
sus.2	sus.2	sus.2	—	sus.2	sus.2	sus.2	—
7 sus.4	7sus.4	7sus.4	7sus.4	—	7sus.4	7sus.4	—
7/11 (pentatonic)	7/11	m7/11	m7/11	7/#11	7/11	m7/11	m7/11b5
13 sus.	—	13sus.4	—	13#11sus2	13sus.4	—	—
13 sus.	—	13sus.4	—	13#11sus2	13sus.4	—	—

## Usuable Harmonic Minor Scale-Tone Chords

type	I	II	bIII	IV	V	bVI	VII
triad	minor	diminished	augmented	minor	maj. or aug.	major	dim. or aug.
seventh	min.(ma7)	m7b5 or dim.7	ma7#5	m7,°7	7,7#5	ma7 or dim.7	dim. 7
ninth	m9(ma7)	—	ma9#5	m7	7b9,7#5b9	—	—
eleventh	—	—	—	—	11b9(rare)	—	—
thirteenth	—	—	—	—	—	—	—
sixth	—	—	—	m6	—	6	—
add 9	m/9	—	—	m/9	—	—	—
6/9 (pentatonic)	—	—	—	m6/9	—	—	—
sus.4	sus.4	—	—	—	sus.4	—	—
sus.2	sus.2	—	—	sus.2	—	—	—
7sus.4	Δ7sus.4	—	—	—	7sus.4	—	—
7/11 (pentatonic)	m(ma7)/11	m7/11b5	—	m7/#11	7/11	Δ7/#11	—
13sus.	—	13sus.4	—	ma13#11sus.2	13sus.4	—	—

## Usuable Melodic Minor Scale-Tone Chords

type	I	II	$\flat$ III	IV	V	VI	VII
triad	minor	minor	aug. or maj. $\flat 5$	maj., maj $\flat 5$	maj. or aug.	dim.	dim. or aug.
seventh	min.(ma7)	m7	ma7#5, ma7 $\flat 5$	7 or 7 $\flat 5$	7 or 7#5	m7 $\flat 5$	7 $\flat 5$ , 7#5
ninth	m9(ma7)	—	ma9#5, ma9 $\flat 5$	9, 9 $\flat 5$	9, 9#5	m9 $\flat 5$	7+5+9
eleventh	—	—	ma9#11	—	11, 11#5	—	—
thirteenth	—	—	ma13#11n5	—	—	—	—
sixth	m6	m6	—	.6	—	—	—
add 9	m/9	—	/9 n5	/9	/9	—	—
6/9 (pentatonic)	m6/9	—	6/9 n5	6/9	—	—	—
sus. 4	sus.4	sus.4	—	—	sus.4	—	—
sus. 2	sus.2	—	—	sus.2	sus.2	—	—
7sus. 4	ma7sus.4	7sus.4	—	—	7sus.4	7sus.4 n5	—
7/11 (pentatonic)	m(ma7)/11	m7/11	—	7/#11	7/11	m7/11 $\flat 5$	—

## Usuable Harmonic Minor Scale-Tone Chords

type	I	II	$\flat$ III	IV	V	$\flat$ VI	VII
triad	minor	diminished	augmented	minor	maj. or aug.	major	dim. or aug.
seventh	min.(ma7)	m7 $\flat 5$ or dim.7	ma7#5	m7, $^{\circ}$ 7	7, 7#5	ma7 or dim.7	dim. 7
ninth	m9(ma7)	—	ma9#5	m7	7 $\flat 9$ , 7#5 $\flat 9$	—	—
eleventh	—	—	—	—	11 $\flat 9$ (rare)	—	—
thirteenth	—	—	—	—	—	—	—
sixth	—	—	—	m6	—	6	—
add 9	m/9	—	—	m/9	—	—	—
6/9 (pentatonic)	—	—	—	m6/9	—	—	—
sus.4	sus.4	—	—	—	sus.4	—	—
sus.2	sus.2	—	—	sus.2	—	—	—
7sus.4	$\Delta$ 7sus.4	—	—	—	7sus.4	—	—
7/11 (pentatonic)	m(ma7)/11	m7/11 $\flat 5$	—	m7/#11	7/11	$\Delta$ 7/#11	—
13sus.	—	13sus.4	—	ma13#11sus.2	13sus.4	—	—

# Scale-Tone Chord Pairs

## Major Scale-Tone Triad Pairs

<u>root movement</u>	<u>chord types</u>	<u>chord pair</u>	<u>between roots</u>	<u>Key of C</u>	<u>Key of A</u>
stepwise	Major to minor	I IIm V VIm	1 step (2 frets) 1 step	C Dm G Am	A Bm E F#m
	Major to Major	IV V	1 step	F G	D E
	minor to minor	IIIm IIIIm	1/2 step (1fret)	Dm Em	Bm C#m
	minor to Major	IIIIm IV	1/2 step	Em F	C#m D
thirds	dimin. to Major	VIIIdim I	1/2 step	Bdim C	G#dim A
	Major to minor	I IIIIm IV VIm	2 steps (4 frets) 2 steps	C Em F Am	A C#m D F#m
	Major to dimin.	V VIIIdim	2 steps	G Bdim	E G#dim
	minor to Major	IIIm IV IIIIm V VIm I	1 1/2 steps (3 frets) 1 1/2 steps 1 1/2 steps	Dm F Em G Am C	Bm D C#m E F#m A
perfect fourths	dimin. to minor	VIIIdim IIIm	1 1/2 steps	Bdim Dm	G#dim Bm
	Major to Major	I IV V I	2 1/2 steps (5 frets) 2 1/2 steps	C F G C	A D E A
	minor to Major	IIIm V	2 1/2 steps	Dm G	Bm E
	minor to minor	IIIIm VIm VIm IIIm	2 1/2 steps 2 1/2 steps	Em Am Am Dm	C#m F#m F#m Bm
dimin. to minor	VIIIdim IIIIm	2 1/2 steps	Bdim Em	G#dim C#m	

## Harmonic Minor Scale Tone Chord Pairs

<u>root movement</u>	<u>chord types</u>	<u>chord pair</u>	<u>between roots</u>	<u>Key of C</u>	<u>Key of A</u>
stepwise	Major to Major	V bVI	1/2 step	G Ab	E F
	dim.7 to minor	VII°7 Im	1/2 step	B°7 Cm	G#°7 Am
	minor to Major	IVm V	1 step	Fm G	Dm E
thirds	Major to minor	bVI Im	2 steps	Ab Cm	F Am
	minor to Major	IVm bVI	1 1/2 steps	Fm Ab	Dm F
	dim.7 to dim.7	II°7 to IV°7	1 1/2 steps	D°7 F°7	B°7 D°7
		or IV°7 to bVI°7	1 1/2 steps	F°7 Ab°7	D°7 F°7
		or bVI°7 to VII°7	1 1/2 steps	Ab°7 B°7	F°7 G#°7
or VII°7 to II°7	1 1/2 steps	B°7 D°7	G#°7 D°7		
perfect fourths	m7b5 to 7	IIIm7b5 V7	2 1/2 steps	Dm7b5 G7	Bm7b5 E7
	7 to minor	V7 Im	2 1/2 steps	G7 Cm	E7 Am
	minor to minor	Im IVm	2 1/2 steps	Cm Fm	Am Dm
	aug. to Major	bIII+ bVI	2 1/2 steps	Eb+ Ab	C+ F

# Scale-Tone 9th, 11th and 13th Chords

The graph on the left of the chart below shows the scales in which the chords are contained.

same octave shape down each column; same type across each row

major scale	Lydian	Mixolydian	Mixolydian #4	Dorian	Dorian #4	Aeolian	641 root	42 root	52 root	53 root	631 root		
$\Delta 7$ 246	$\Delta 7$ 2 #4 6	7 246	7 246	m7 246	m7 2#46	m7 2 4 b6							
							<b>9</b> (nr = m7b5) 						
							<b>13</b> 						
							<b>7#9</b> m7 superimposed over 7 						
							$\Delta 9$ (nr = m7) 						
							$\Delta 7\#11$ (nr=m/9) 						
							$\Delta 9\#11$ (nr = m9) 						
							<b>m9</b> (nr = maj7) 						
							<b>m13</b> (nr = $\Delta 9\#11$ ) 						
$\Delta 7$ 246	$\Delta 7$ 2 #4 6	7/11 246	7/11 246	m7 246	m7 2#46	m7 2 4 b6							

# Scale-Tone Altered Dominant Chords

The graph on the left of the chart below shows the scales in which the chords are contained.

melodic minor V		Phrygian major harmonic minor V		melodic minor VII		diminished half/whole		whole tone		melodic minor IV	
mmV	PM	mmVII	Dhw	WT	mmIV						
7	7	7±5±9	13	9±5	7						
2 4 b6	b2 4 b6			±9#11	2 #4 6						
						<b>641 root</b>	<b>42 root</b>	<b>52 root</b>	<b>53 root</b>	<b>631 root</b>	
						<b>7b9</b> (nr=°7) b7 3 5 b2	b2 5 b7 3	1 3 b7 b2	b2 5 b7 3	b7 5 b2 3	
						<b>7#5b9</b> (7#5b9nr=bVIIIm7b5 7#5b9 =bV9#11nr =bVIIIm9b5) 1 b7 3 #5 b2	#5 1 3 b7 b2	b7 3 #5 b2	1 3 b7 b2 #5	3 b7 b2 #5	#5 1 3 b7 b2
						<b>7#5</b> 1 b7 3 #5	#5 1 b7 3	b7 #5 1 3	1 b7 3 #5	#5 1 3 b7	b7 3 #5 1
						<b>7b5</b> (=bV7b5) 1 b7 3 b5	1 b5 b7 3	1 3 b5 b7	1 b5 b7 3	3 b7 1 b5	b5 1 3 b7
						<b>9b5</b> (=bV7b5/#5) b5 1 3 b7 2		3 b7 2 b5	b5 2 3 b7		b7 3 b5 2
						<b>9#5</b> (9#5nr =III7b5 =bVIIb5) b7 3 #5 2	3 #5 b7 2	b7 3 #5 2	3 #5 b7 2	3 b7 2 #5	
						<b>7/6b5</b> (7/6b5nr =bV7#9#5) 1 b5 b7 3 6	b7 3 b5 6	b5 b7 3 6 1	b5 1 3 b7 2 6	b5 b7 1 3 6	
						<b>7b5b9</b> (7b5b9 =bV7 / I =bV7#11) b5 b7 3 b2	b5 1 3 b7 b2	1 3 b7 b2 b5	b5 b2 3 b7	1 3 b7 b2 b5	
						<b>13b5b9</b> (13b5b9nm11 =bV7#9) b5 b7 3 6 b2		b5 b7 3 6 b2	b5 1 3 b7 b2 6	b5 b7 b2 3 6	
						<b>7b5#9</b> (7b5#9 =bV7/6b5) b5 1 3 b7 b3		1 3 b5 b7 b3		1 3 b7 #2 b5	
						<b>7#5#9</b> (7#5#9 =bV9/6nm5) 1 b7 3 #5 b3	#5 3 b7 b3	1 3 #5 b7 b3	1 3 b7 #5 b3	3 b7 b3 #5	

mmV 7/11 2 b6 PM 7/11 b2 b6 mmVII 7±5±9 13 ±9#11 Dhw 13 9±5 WT 9±5 mmIV 7#11 2 6

13 b9 #9 #11 = half/whole diminished scale \*\*\* melodic minor IV = 13#11 \*\*\* melodic minor V = 11b13



# Scale-Tone Add-Tone and Suspended Chords

The graph on the left of the chart below shows the scales in which the chords are contained.

	same octave shape down each column; same type across each row						
	641 root	42 root	52 root	53 root	631 root		
major scale							
Lydian							
Mixolydian							
Mixolydian #4							
Phrygian Major							
Dorian							
Dorian #4							
Aeolian							
Phrygian							
	<b>6</b> (major add 6)	<b>m6</b> (minor add 6)	<b>/9</b> (major add 9)	<b>m/9</b> (minor add 9)	<b>sus. 4</b> (suspended 4)	<b>7 sus. 4</b> (dominant 7th suspended 4)	<b>9 sus. 4</b> (dominant 9th suspended 4)



# Chords By Type



- **101 Chord Types**

**(contents begin on the next page)**

## Two Note Chords

major third.....	214
minor third .....	214
perfect fifth.....	214

## Triads

major .....	215
minor .....	219
diminished.....	223
augmented.....	226
major flat five .....	229
suspended fourth .....	233
suspended second.....	234

## Major Type Chords

major seventh.....	235
major seventh no third .....	239
major seventh add six.....	240
major seventh add sharp eleven .....	241
major seventh add six add sharp eleven.....	242
major seventh add six flat five .....	242
major seventh suspended fourth.....	243
major seventh suspended second .....	245
major seventh flat five.....	248
major seventh sharp five .....	251
major ninth.....	252
major ninth no third .....	253
major ninth add six.....	256
major ninth sharp eleven.....	257
major ninth flat five.....	258
major ninth sharp five .....	259
major thirteenth sharp eleven.....	260

sixth.....	261
sixth add nine .....	263
sixth add nine add sharp eleven .....	267
sixth add nine flat five .....	269
add nine (major add nine) .....	270

## Dominant Seventh Type Chords (no altered fifths)

dominant seventh .....	271
dominant seventh no third.....	275
dominant seventh add six.....	276
dominant seventh add six suspended fourth.....	278
dominant seventh add six flat nine.....	280
dominant seventh add six add sharp eleven ...	281
dominant seventh add sharp eleven .....	282
dominant seventh suspended fourth.....	284
dominant seventh suspended second .....	286
dominant seventh flat nine .....	290
dominant seventh flat nine suspended fourth ...	292
dominant seventh flat nine sharp nine.....	293
dominant seventh flat nine sharp eleven .....	295
dominant seventh sharp nine.....	296
dominant seventh sharp nine sharp eleven....	297

## Dominant Type Chords With Flat Five (includes those with $\flat 5$ and $\sharp 5$ )

dominant seventh flat five .....	299
dominant seventh add six flat five.....	301
dominant seventh add six flat five flat nine... 302	
dominant seventh flat five sharp five .....	303
dominant seventh flat five flat nine .....	304
dominant seventh flat five flat nine sharp nine... 306	
dominant seventh flat five sharp nine.....	307
dominant seventh flat five sharp five flat nine.... 308	
dominant seventh flat five sharp five sharp nine .. 308	

**Dominant Type Chords With Sharp Five (no<sup>b</sup>5)**

dominant seventh sharp five..... 309  
 dominant seventh sharp five flat nine..... 310  
 dominant seventh sharp five flat nine sharp nine . 310  
 dominant seventh sharp five sharp nine ..... 311

**Dominant Ninth Type Chords (no altered 5ths)**

dominant ninth ..... 313  
 dominant ninth no third..... 315  
 dominant ninth suspended fourth..... 319  
 dominant ninth add six..... 320  
 dominant ninth add six suspended fourth ..... 321  
 dominant ninth add six add sharp eleven..... 321  
 dominant ninth add sharp eleven ..... 322

**Dominant Ninth Type Chords With Altered Fifths**

dominant ninth flat five ..... 323  
 dominant ninth sharp five..... 324  
 dominant ninth flat five sharp five ..... 324  
 dominant ninth add six flat five..... 325

**Dominant Eleventh & Thirteenth Chords**

dominant eleventh no third ..... 325  
 dominant thirteenth ..... 326  
 dominant thirteenth suspended fourth..... 329  
 dominant thirteenth sharp eleven ..... 331  
 dominant thirteenth flat nine ..... 332  
 dominant thirteenth flat five flat nine ..... 333  
 dominant thirteenth flat five sharp nine ..... 333  
 dominant thirteenth flat nine suspended fourth.. 334

**Minor Add Nine.....335**

**Minor Seventh Type Chords (includes m9, m11, m13 types)**

minor seventh..... 336  
 minor seventh add six ..... 340  
 minor seventh add eleven..... 342  
 minor ninth..... 346  
 minor ninth add six ..... 349  
 minor eleventh ..... 350  
 minor thirteenth..... 356

**Minor Sixth Type Chords**

minor sixth ..... 359  
 minor sixth add nine..... 361

**Minor (major seventh) Type Chords (includes m9(major 7) types)**

minor (major seventh)..... 362  
 minor (major seventh) add six ..... 363  
 minor ninth (major seventh)..... 365  
 minor ninth (major seventh) add six ..... 366

**Minor Seventh Flat Five Type Chords (includes m9b5 and m11b5 types)**

minor seventh flat five..... 367  
 minor add eleven flat five..... 369  
 minor ninth flat five..... 371  
 minor eleventh flat five ..... 373

**Minor (major seventh) Flat Five Type Chords**

minor (major seventh) flat five..... 376  
 minor ninth (major seventh) flat five ..... 377

**Diminished Seventh Type Chords**

diminished seventh..... 378  
 diminished seventh add nine..... 379

# major third

C mi3	I	C mi3	IV	C mi3	VI	C mi3	VIII	C mi3	XI
1 b3		1 b3		1 b3		1 b3		1 b3	

# minor third

C mi3	I	C mi3	IV	C mi3	VI	C mi3	VIII	C mi3	XI
1 b3		1 b3		1 b3		1 b3		1 b3	

# perfect fifth

C 5	I	C 5	III	C 5	III	C 5	V	C 5	V
1 5		1 5		1 5		5 1		1 5 1 5	
C 5	V	C 5	V	C 5	VIII	C 5	VIII	C 5	X
1 5		1 5		1 5		1 5		5 1 5 1	
C 5	X	C 5	XII	C 5	XII				
1 5		1 5 1 5		1 5					

# major

C major I 	C major I 	C major I 	C major I 	C major II 
C major II 	C major II 	C major II 	C major II 	C major II 
C major II 	C major II 	C major III 	C major III 	C major III 
C major III 	C major III 	C major III 	C major III 	C major III 
C major III 	C major III 	C major III 	C major III 	C major III 

C major III

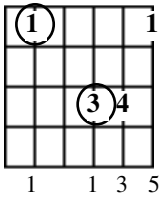

C major V

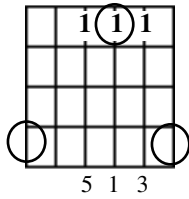

C major V

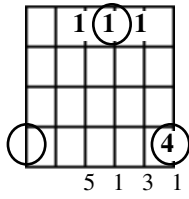

C major V

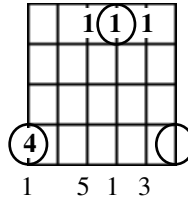

C major V

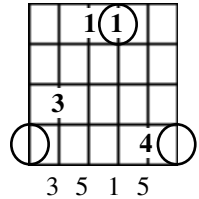

C major V

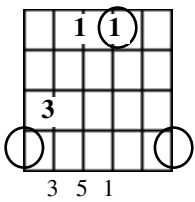

C major V

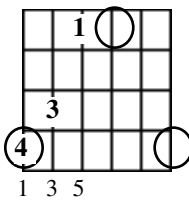

C major V

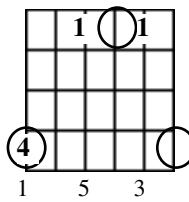

C major V

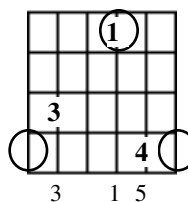

C major V

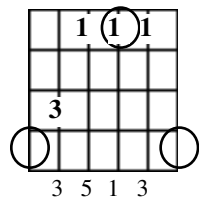

C major V

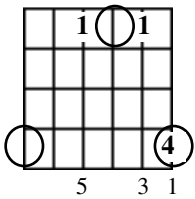

C major V

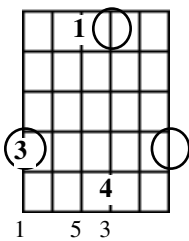

C major V

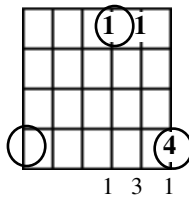

C major V

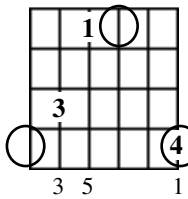

C major V

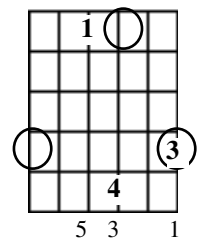

C major V

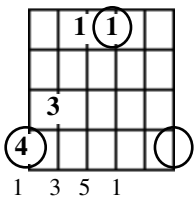

C major V

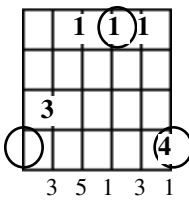

C major VII

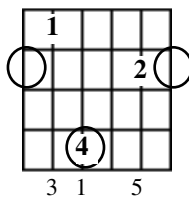

C major VII

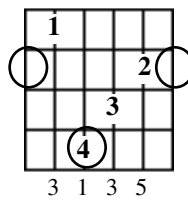

C major VII

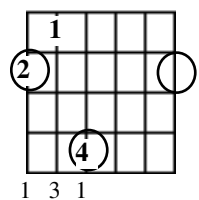

C major VII

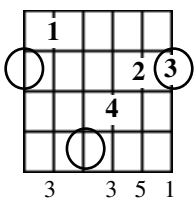

C major VIII

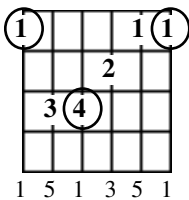

C major VIII

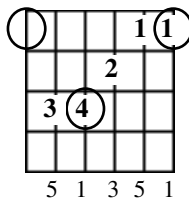

C major VIII

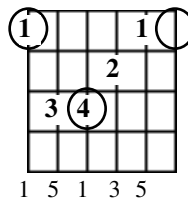

C major VIII

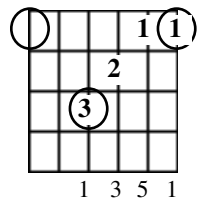



C major VIII

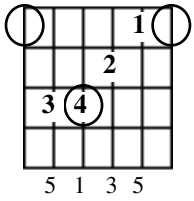

C major VIII

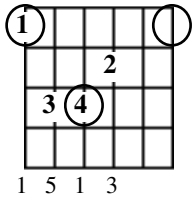

C major VIII

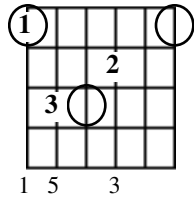

C major VIII

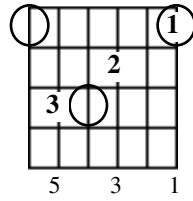

C major VIII

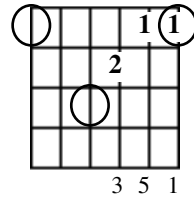

C major VIII

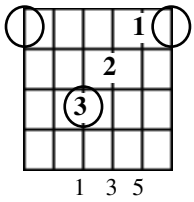

C major VIII

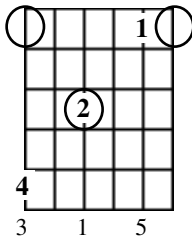

C major VIII

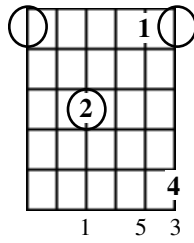

C major VIII

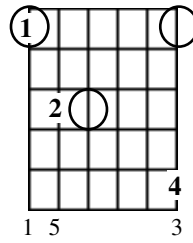

C major VIII

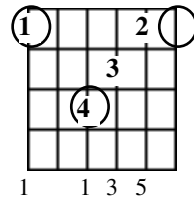

C major VIII

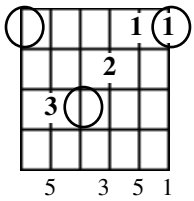

C major VIII

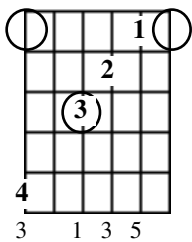

C major VIII

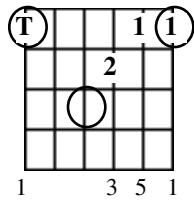

C major IX

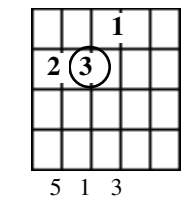

C major IX

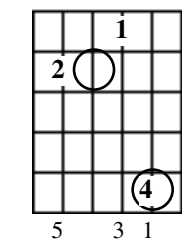

C major IX

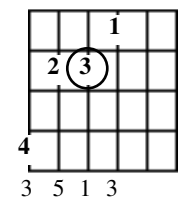

C major X

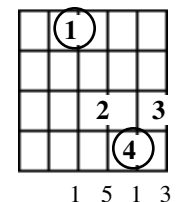

C major X

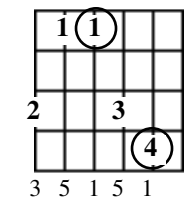

C major X

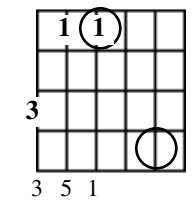

C major X

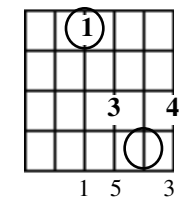

C major X

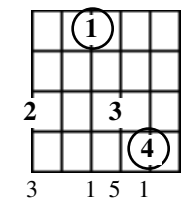

C major X

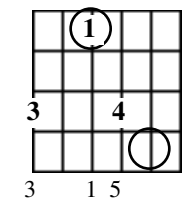

C major X

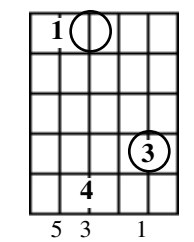

C major X

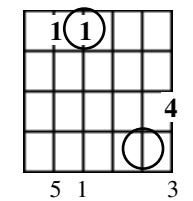

C major X

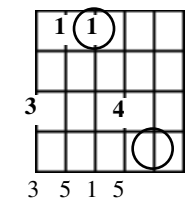

C major X

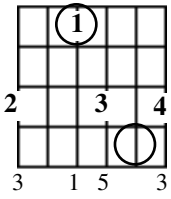

C major X

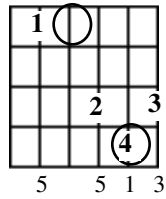

C major X

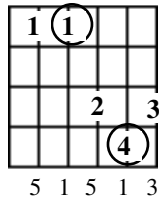

C major XII

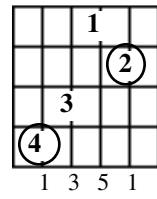

C major XII

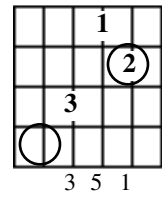

C major XII

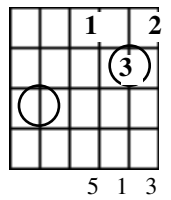

C major XII

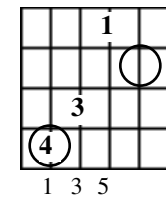

C major XII

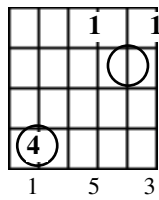

C major XII

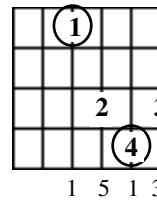

C major XII

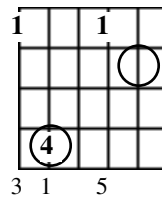

C major XII

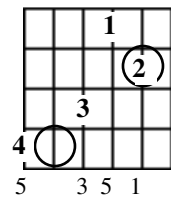

C major XII

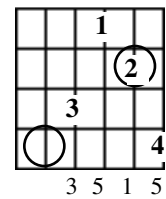

C major XII

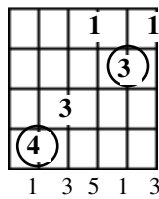

C major XII

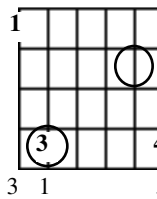

C major XII

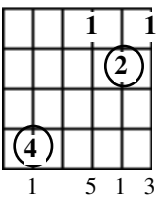

C major XII

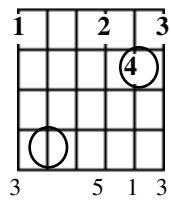

C major XII

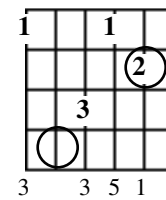

C major XII

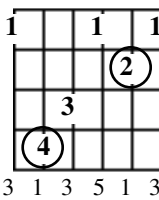

C major XII

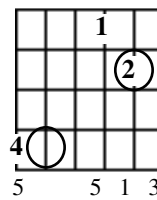

C major XII

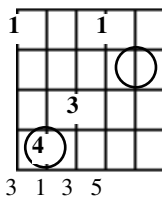

C major XII

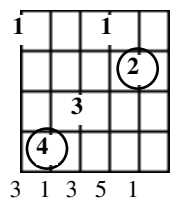

C major XII

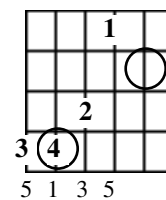

# minor

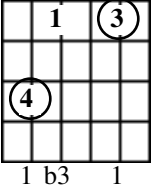
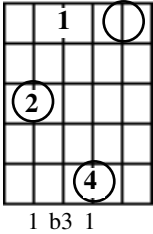
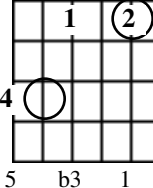
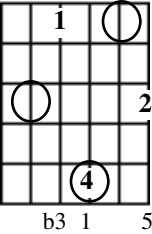
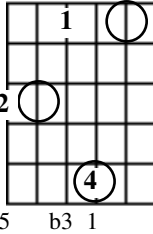
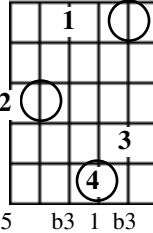
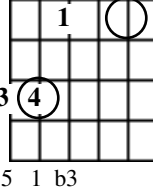
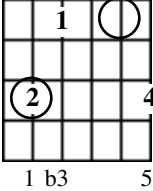
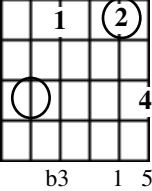
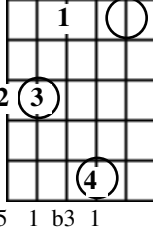
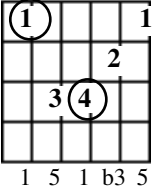
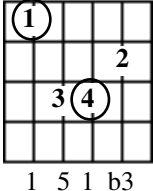
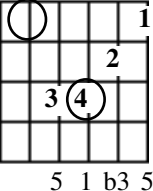
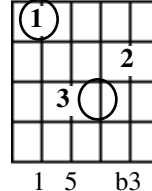
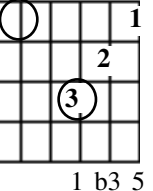
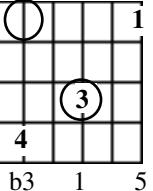
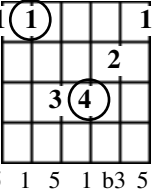
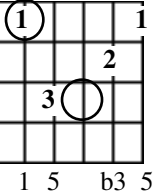
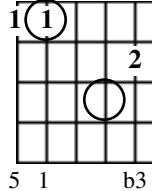
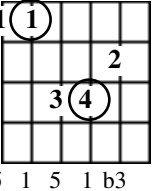
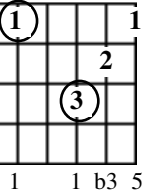
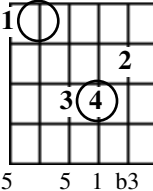
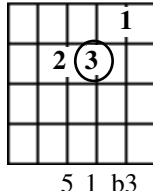
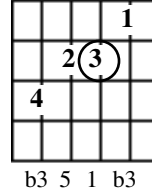
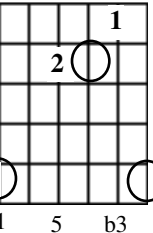
C minor I 	C minor I 	C minor I 	C minor I 	C minor I 
C minor I 	C minor I 	C minor I 	C minor I 	C minor I 
C minor III 	C minor III 	C minor III 	C minor III 	C minor III 
C minor III 	C minor III 	C minor III 	C minor III 	C minor III 
C minor III 	C minor III 	C minor IV 	C minor IV 	C minor IV 

C minor IV

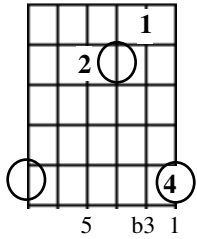

C minor V

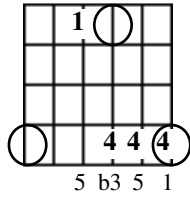

C minor V

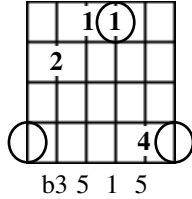

C minor V

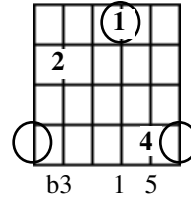

C minor V

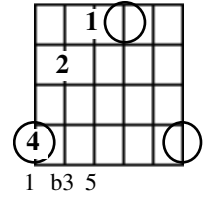

C minor V

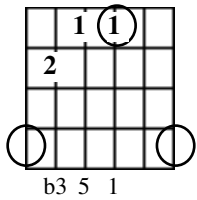

C minor V

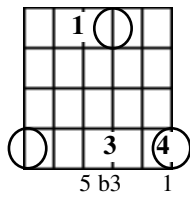

C minor V

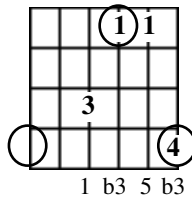

C minor V

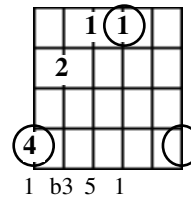

C minor V

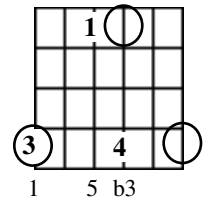

C minor VI

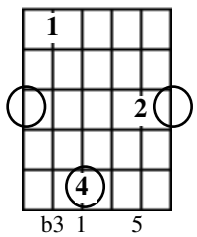

C minor VI

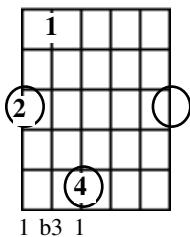

C minor VI

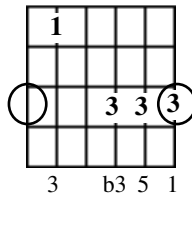

C minor VIII

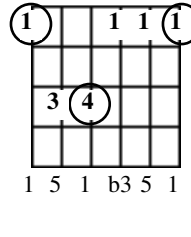

C minor VIII

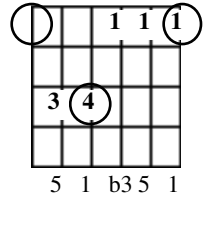

C minor VIII

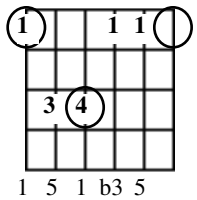

C minor VIII

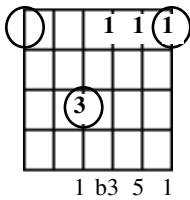

C minor VIII

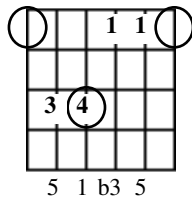

C minor VIII

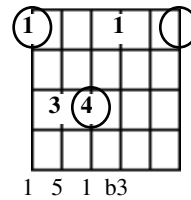

C minor VIII

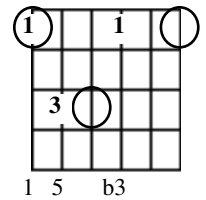

C minor VIII

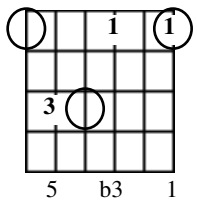

C minor VIII

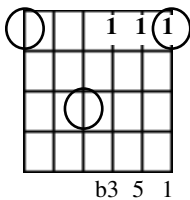

C minor VIII

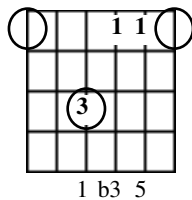

C minor VIII

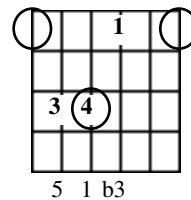

C minor VIII

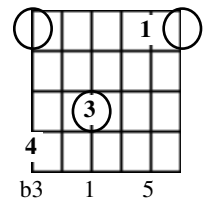



C minor XII

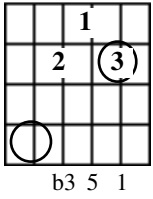

C minor XII

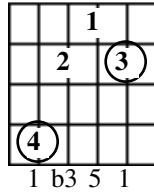

C minor XII

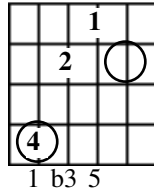

C minor XII

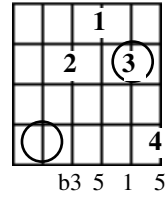

C minor XII

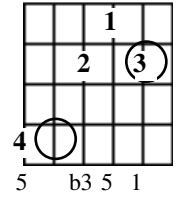

C minor XII

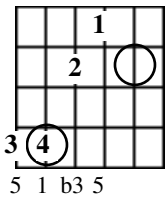

C minor XII

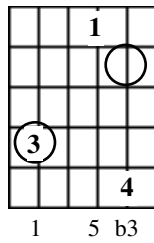

# diminished

C dim I  b5 1 b3	C dim I  b3 1 b5	C dim I  5 b3 1	C dim I  b5 b3 1	C dim I  b3 1 b5
C dim I  b5 1 b3 1	C dim II  1 b3 b5	C dim II  b5 1 b3 b5	C dim II  1 1 b3 b5	C dim II  b5 b5 1 b3
C dim III  1 b5 1 b3	C dim III  1 b5 b3	C dim IV  b5 1 b3	C dim IV  b3b5 1 b5	C dim IV  1 b3 b5
C dim IV  b3 b5 1	C dim IV  1 b3 b5 1	C dim IV  b3 5 1 b3	C dim IV  1 b5 b3	C dim V  b3 1 b5
C dim VI  b3 1 b5	C dim VI  3 b3 b5 1	C dim VII  b3 b5 1	C dim VII  1 b5 b7b3 b5	C dim VII  1 b3 b5

C dim VII

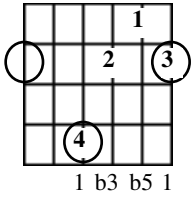

C dim VII

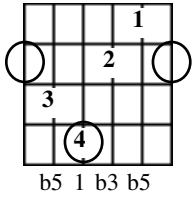

C dim VII

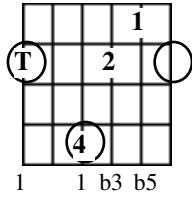

C dim VII

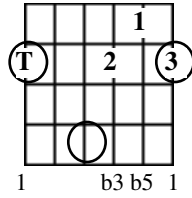

C dim VII

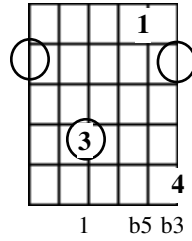

C dim VIII

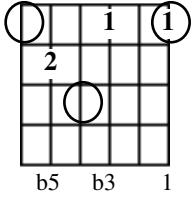

C dim VIII

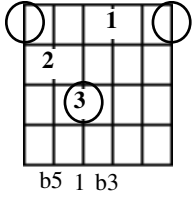

C dim VIII

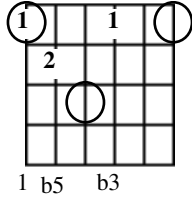

C dim VIII

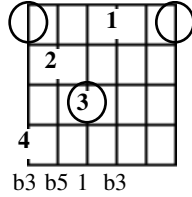

C dim VIII

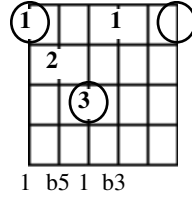

C dim IX

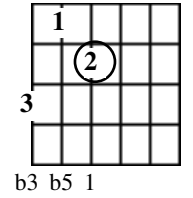

C dim IX

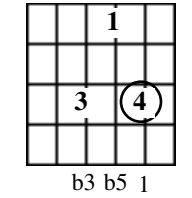

C dim IX

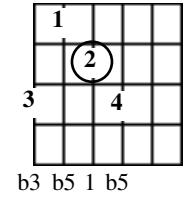

C dim IX

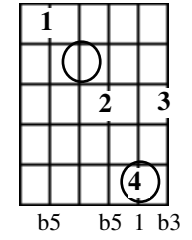

C dim X

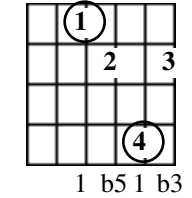

C dim X

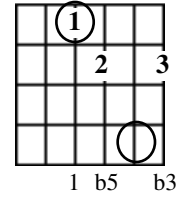

C dim X

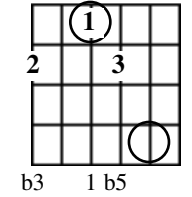

C dim X

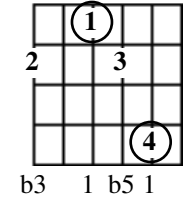

C dim X

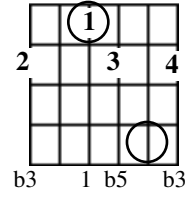

C dim XI

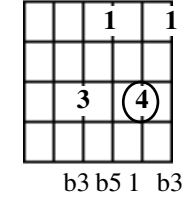

C dim XI

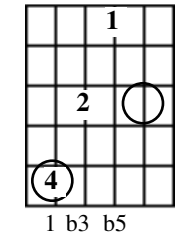

C dim XI

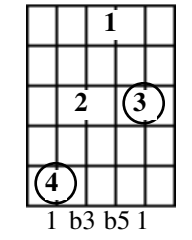

C dim XI

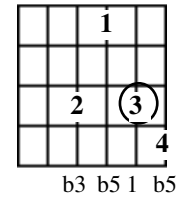

C dim XI

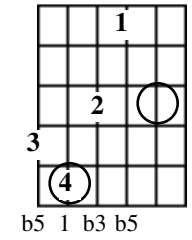

C dim XI

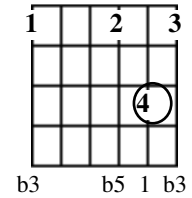



C dim XI

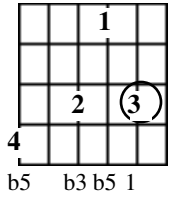

C dim XI

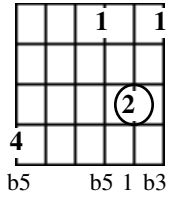

C dim XI

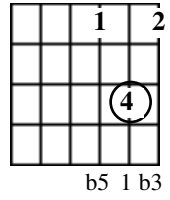

C dim XI

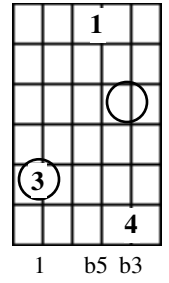

# augmented

C aug I

1 3 #5 1

C aug I

#5 1 3 #5

C aug I

#5 1 3 #5 1

C aug I

1 3 #5 1 #5

C aug I

#5 3 #5 1

C aug I

3 #5 1 #5

C aug I

#5 1 3 1

C aug II

#5 1 3

C aug III

#5 1 1 3

C aug III

1 1 3 #5

C aug III

1 #5 1 3

C aug III

1 #5 3

C aug III

1 3 #5

C aug IV

#5 1 3 #5

C aug IV

#5 #5 1 3

C aug IV

#5 1 3 #5

C aug IV

#5 #5 1 3 #5

C aug IV

#5 3 #5 1

C aug V

3 #5 1 3

C aug V

1 3 #5 1

C aug V

1 3 #5 1 3

C aug V

3 #5 1 3 1

C aug V

1 #5 1 3

C aug V

#5 1 3 1

C aug V

1 3 #5 3

C aug VI

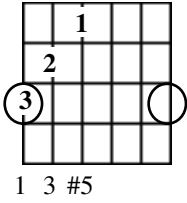

C aug VII

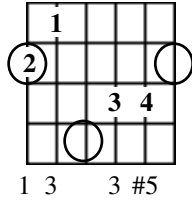

C aug VII

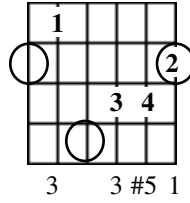

C aug VII

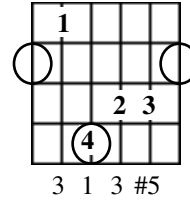

C aug VII

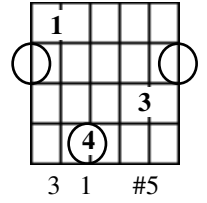

C aug VII

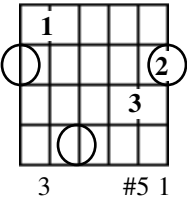

C aug VIII

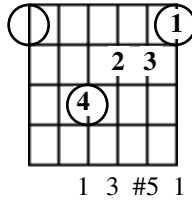

C aug VIII

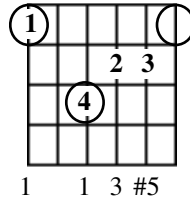

C aug VIII

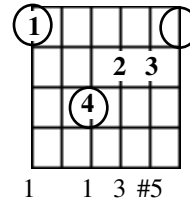

C aug VIII

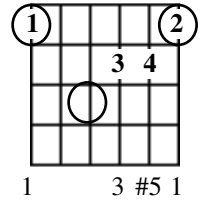

C aug VIII

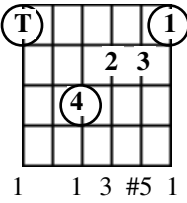

C aug VIII

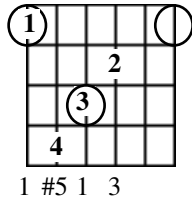

C aug IX

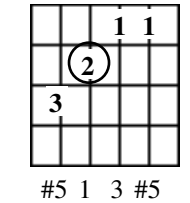

C aug IX

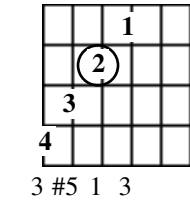

C aug IX

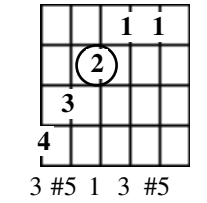

C aug IX

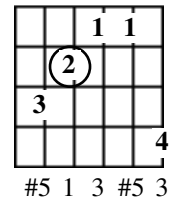

C aug IX

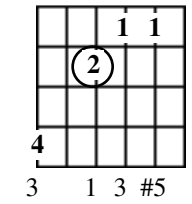

C aug IX

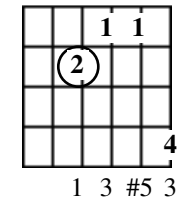

C aug IX

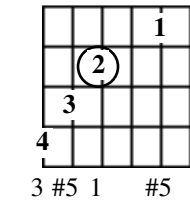

C aug X

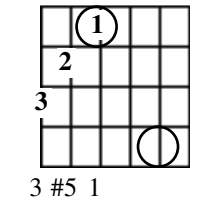

C aug XI

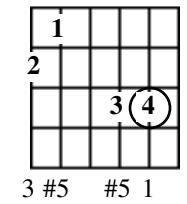

C aug XI

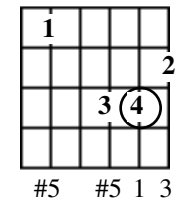

C aug XI

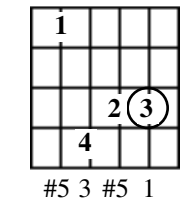

C aug XI

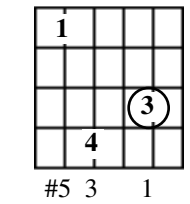

C aug XI

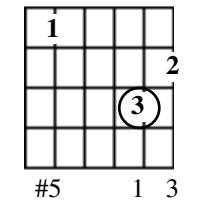

C aug XII

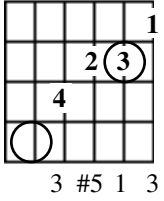

C aug XII

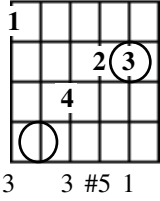

C aug XII

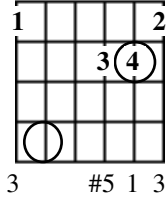

C aug XII

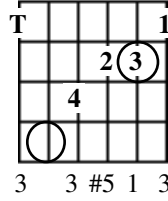

C aug XII

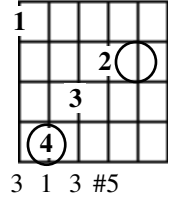

# major flat five

C majb5

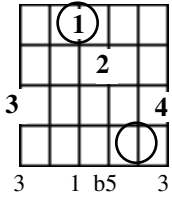

C majb5

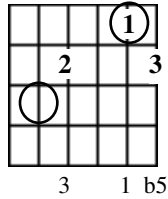

I

C majb5

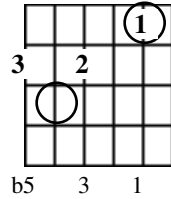

I

C majb5

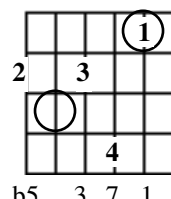

I

C majb5

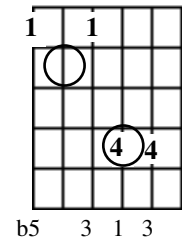

II

C majb5

II

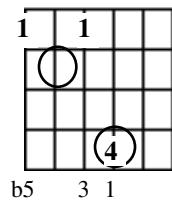

C majb5

II

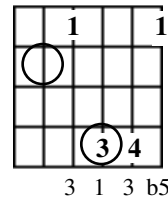

C majb5

II

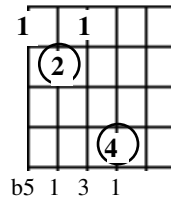

C majb5

II

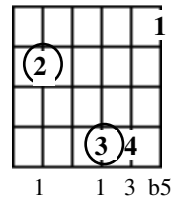

C majb5

II

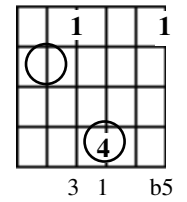

C majb5

II

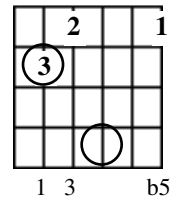

C majb5

II

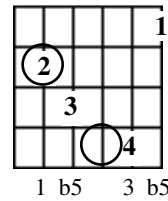

C majb5

II

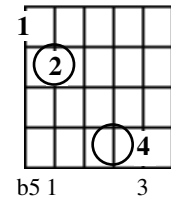

C majb5

II

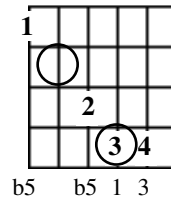

C majb5

II

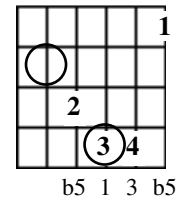

C majb5

II

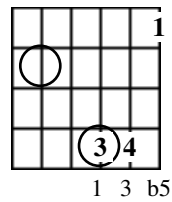

C majb5

II

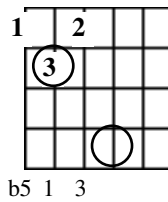

C majb5

II

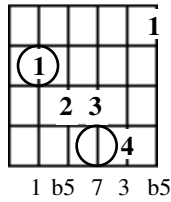

C majb5

II

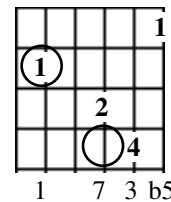

C majb5

II

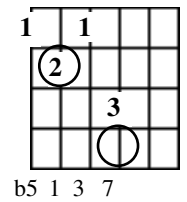

C majb5

III

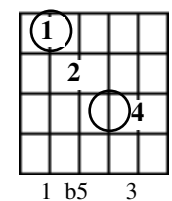

C majb5

III

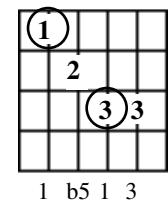

C majb5

III

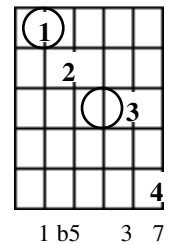

C majb5

III

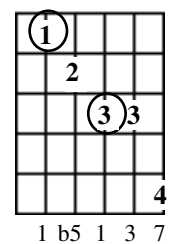

C majb5

IV

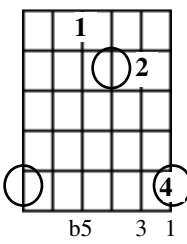

C majb5 IV

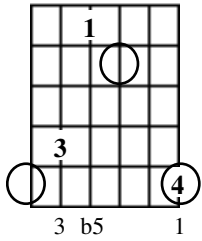

C majb5 IV

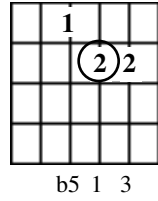

C majb5 IV

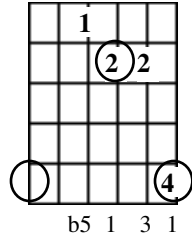

C majb5 IV

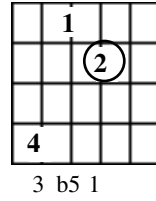

C majb5 IV

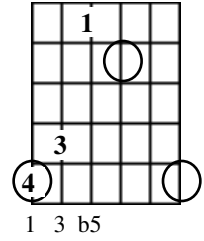

C majb5 IV

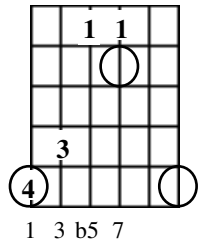

C majb5 V

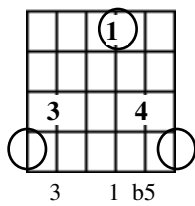

C majb5 V

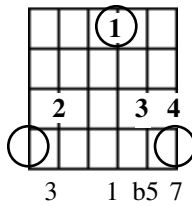

C majb5 V

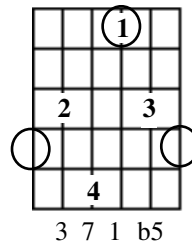

C majb5 VII

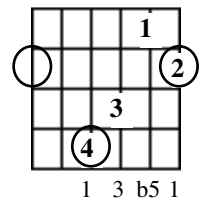

C majb5 VII

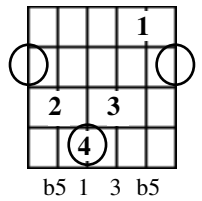

C majb5 VII

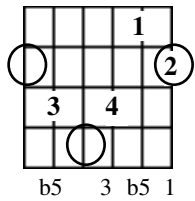

C majb5 VII

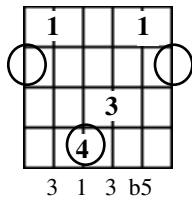

C majb5 VII

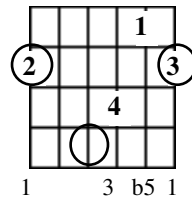

C majb5 VII

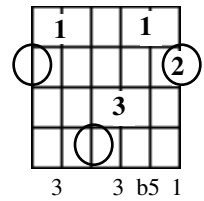

C majb5 VII

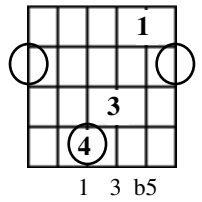

C majb5 VII

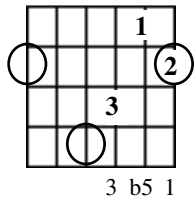

C majb5 VII

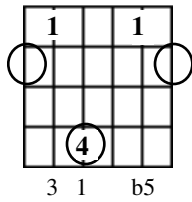

C majb5 VII

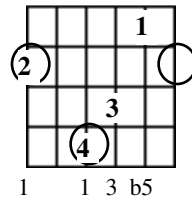

C majb5 VII

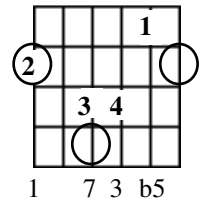

C majb5 VII

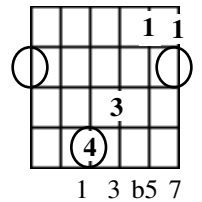

C majb5 VII

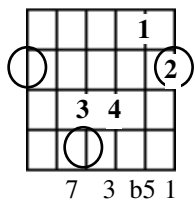

C majb5 VII

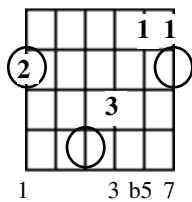

C majb5 VII

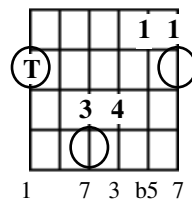

C majb5 VII

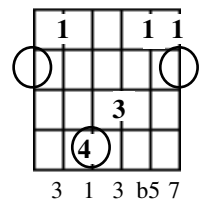



C majb5 XI

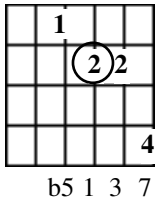

C majb5 XII

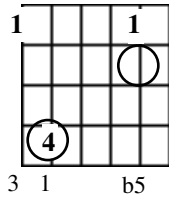

C majb5 XII

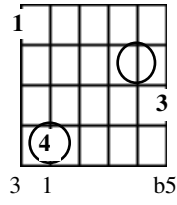

C majb5 XII

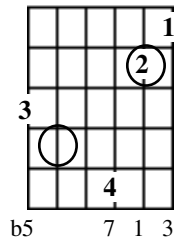



# suspended fourth

C sus4 III

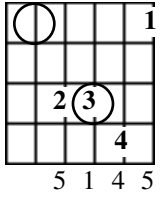

C sus4 III

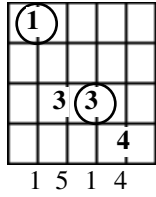

C sus4 III

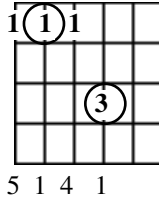

C sus4 III

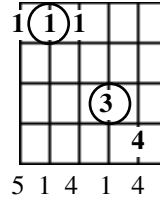

C sus4 III

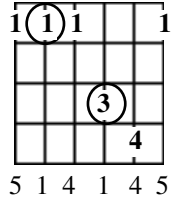

C sus4 III

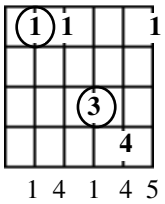

C sus4 III

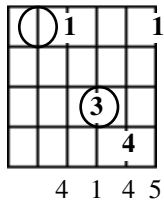

C sus4 III

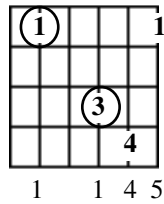

C sus4 V

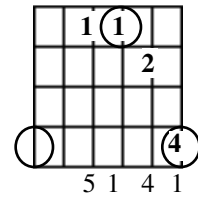

C sus4 V

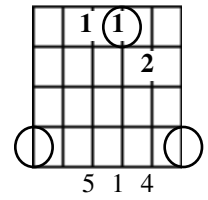

C sus4 V

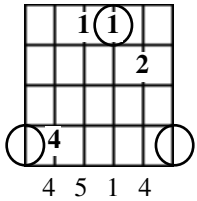

C sus4 VIII

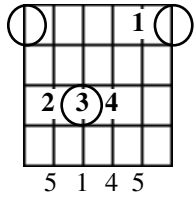

C sus4 VIII

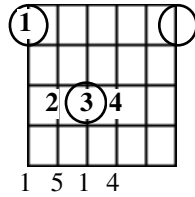

C sus4 VIII

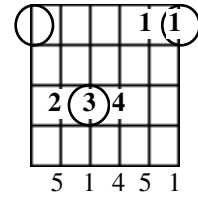

C sus4 VIII

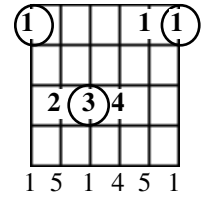

C sus4 IX

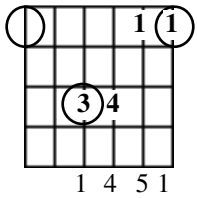

C sus4 X

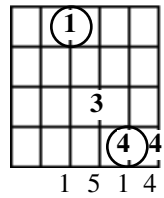

C sus4 X

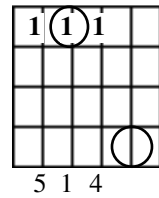

C sus4 X

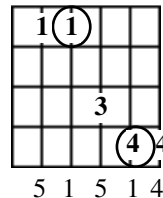

C sus4 XII

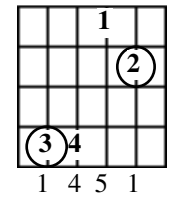

C sus4 XII

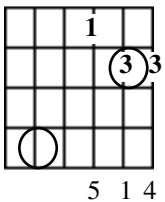

# suspended second

C sus2 III

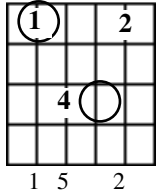

C sus2 III

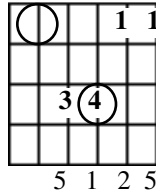

C sus2 III

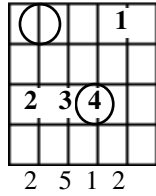

C sus2 III

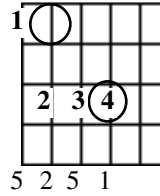

C sus2 III

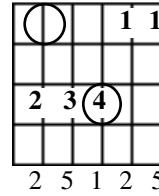

C sus2 V

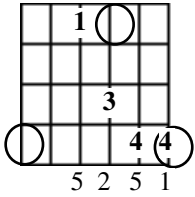

C sus2 V

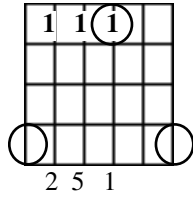

C sus2 VII

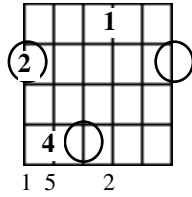

C sus2 VII

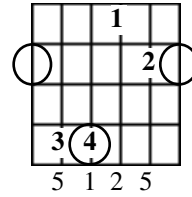

C sus2 VII

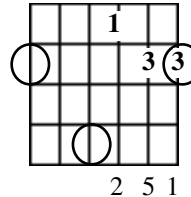

C sus2 VIII

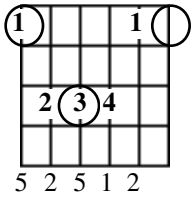

C sus2 VIII

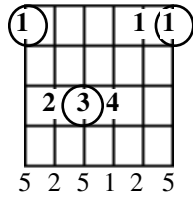

C sus2 X

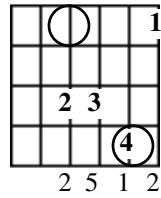

C sus2 X

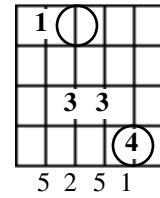

C sus2 X

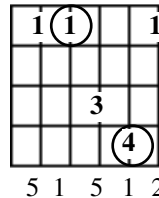

C sus2 X

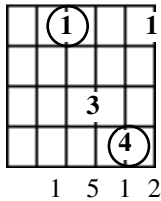

C sus2 X

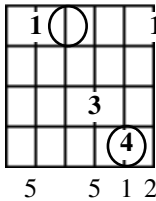

C sus2 XII

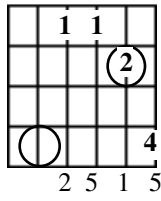

C sus2 XII

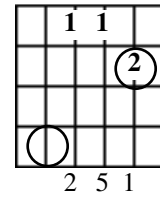

C sus2 XII

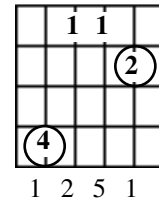

# major seventh

C ma7 I

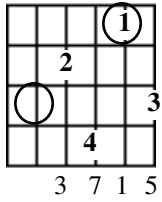

C ma7 I

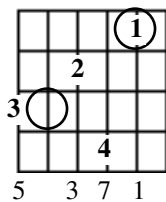

C ma7 I

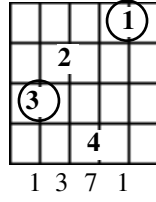

C ma7 II

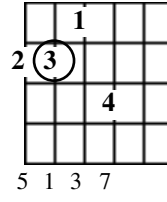

C ma7 nr II

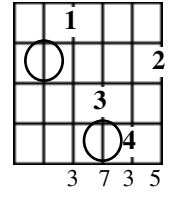

C ma7 nr II

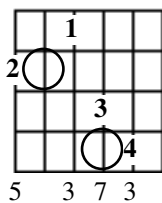

C ma7 nr II

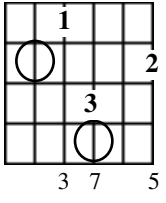

C ma7 nr II

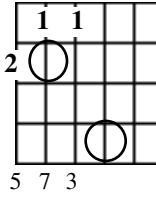

C ma7 nr II

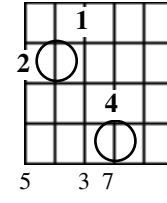

C ma7 nr II

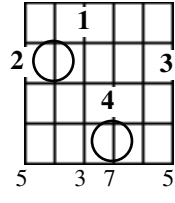

C ma7 III

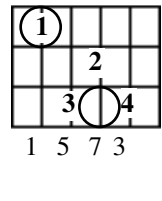

C ma7 III

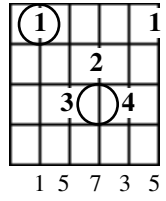

C ma7 III

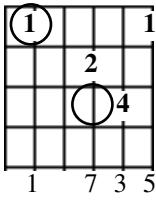

C ma7 III

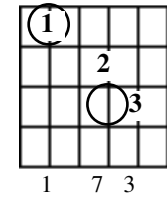

C ma7 III

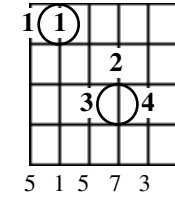

C ma7 III

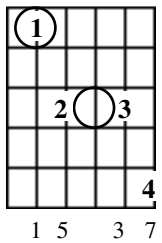

C ma7 III

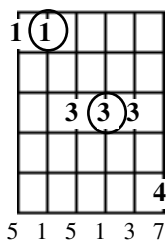

C ma7 III

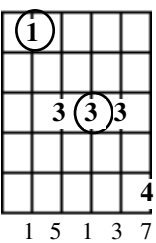

C ma7 nr III

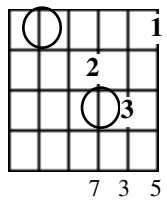

C ma7 nr III

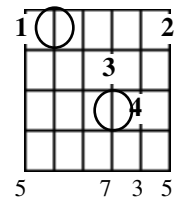

C ma7 IV

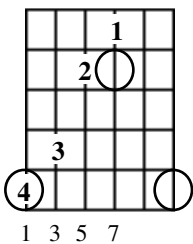

C ma7 nr IV

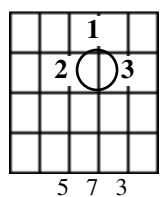

C ma7 nr IV

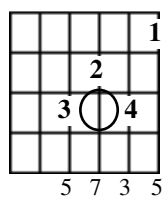

C ma7 nr IV

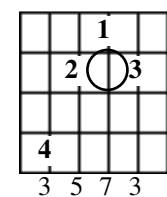

C ma7 nr IV

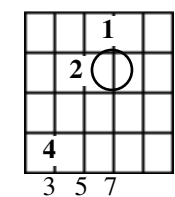

C ma7 V

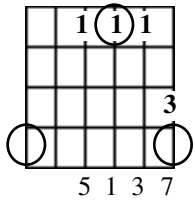

C ma7 V

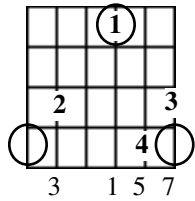

C ma7 V

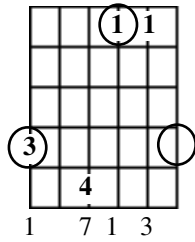

C ma7 V

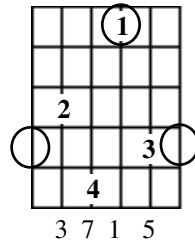

C ma7 V

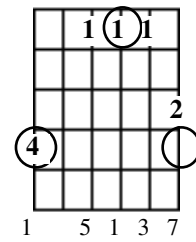

C ma7 nr V

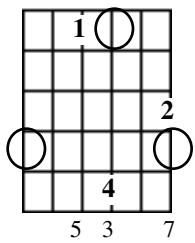

C ma7 nr V

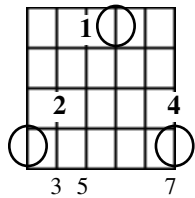

C ma7 nr V

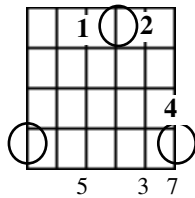

C ma7 VII

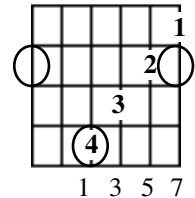

C ma7 VII

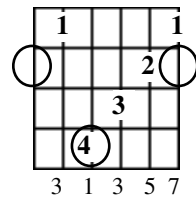

C ma7 VII

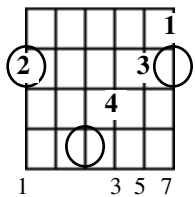

C ma7 VII

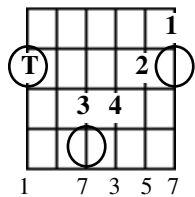

C ma7 VII

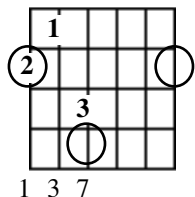

C ma7 nr VII

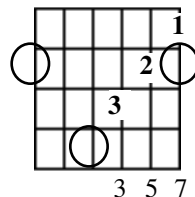

C ma7 nr VII

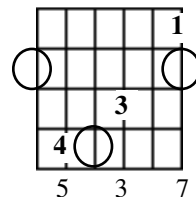

C ma7 nr VII

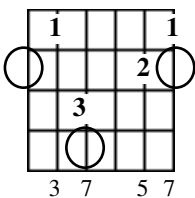

C ma7 nr VII

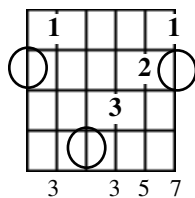

C ma7 VIII

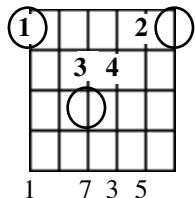

C ma7 VIII

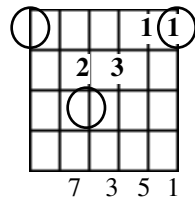

C ma7 VIII

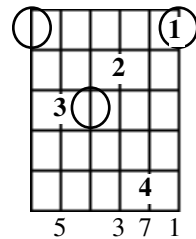

C ma7 VIII

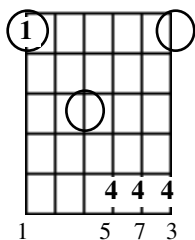

C ma7 VIII

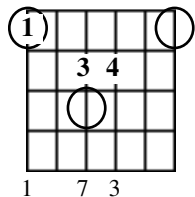

C ma7 VIII

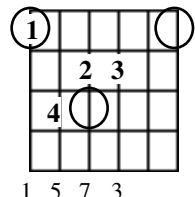

C ma7 VIII

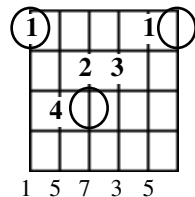

C ma7 VIII

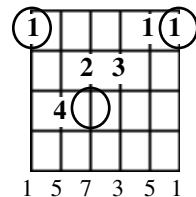

C ma7 VIII

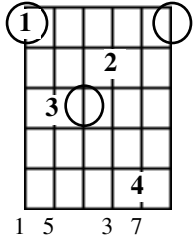

C ma7 VIII

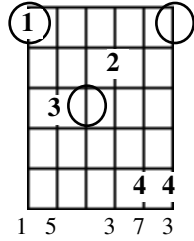

C ma7 VIII

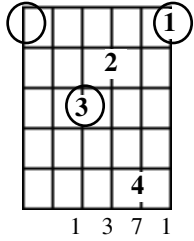

C ma7 IX

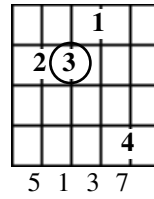

C ma7 IX

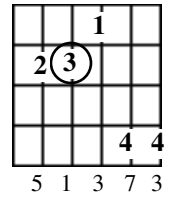

C ma7 nr IX

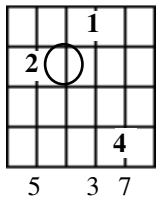

C ma7 nr IX

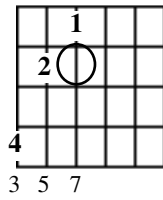

C ma7 nr IX

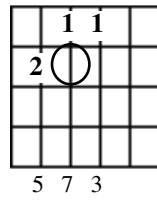

C ma7 nr IX

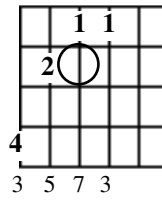

C ma7 X

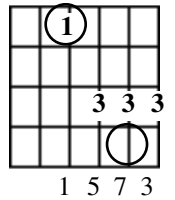

C ma7 X

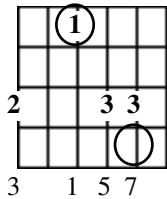

C ma7 X

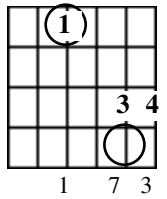

C ma7 X

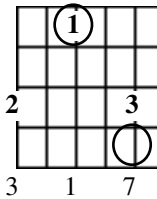

C ma7 X

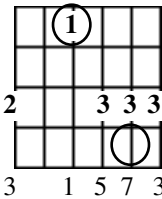

C ma7 X

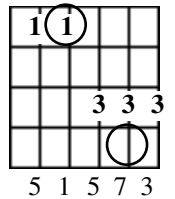

C ma7 X

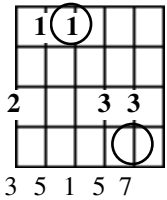

C ma7 nr X

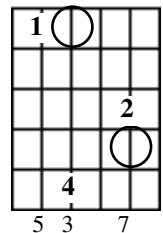

C ma7 nr X

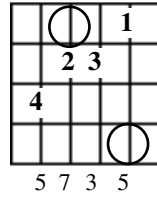

C ma7 nr X

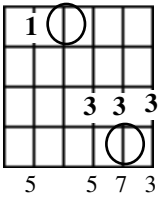

C ma7 XII

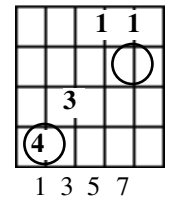

C ma7 XII

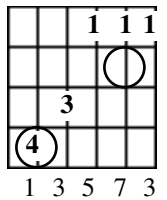

C ma7 XII

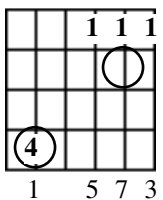

C ma7 XII

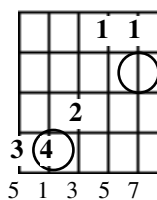

C ma7 XII

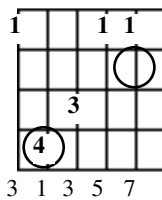

C ma7 XII

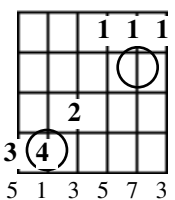

C ma7 XII

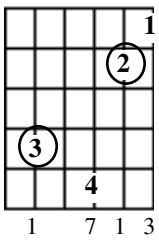

C ma7 XII

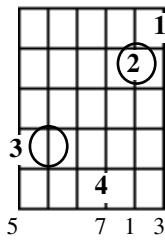

C ma7 nr XII

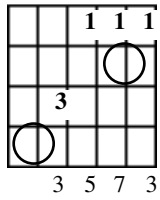

C ma7 nr XII

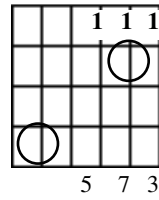

C ma7 nr XII

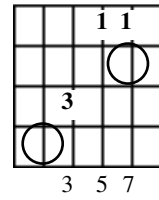

C ma7 nr XII

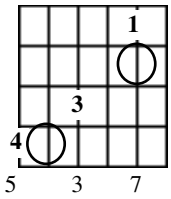

C ma7 nr XII

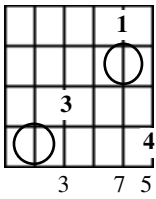

C ma7 nr XII

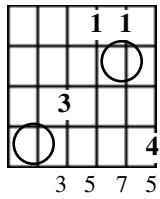

C ma7 nr XII

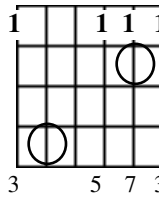

C ma7 nr XII

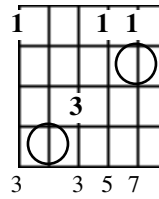

C ma7 nr XII

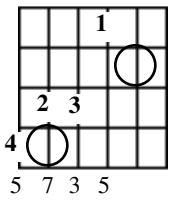

# major seventh no third

C ma7n3 I

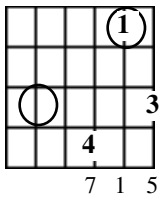

C ma7n3 III

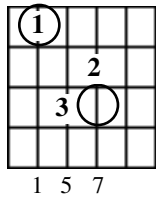

C ma7n3 III

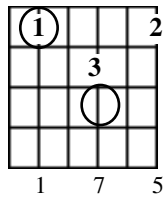

C ma7n3 III

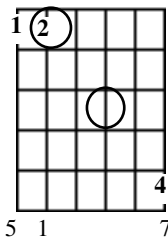

C ma7n3 III

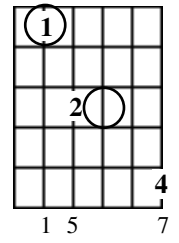

C ma7n3 V

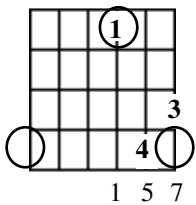

C ma7n3 V

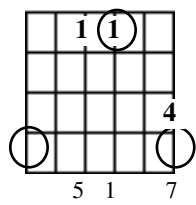

C ma7n3 V

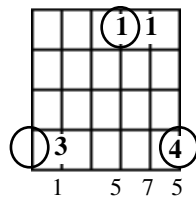

C ma7n3 VIII

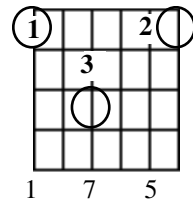

C ma7n3 X

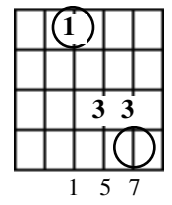

C ma7n3 X

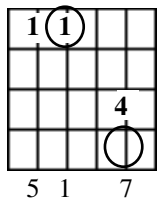

C ma7n3 nr XII

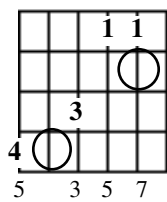

## major seventh add six

C ma7/6 VIII

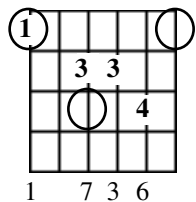



# major seventh add sharp eleven

C ma7#11 II

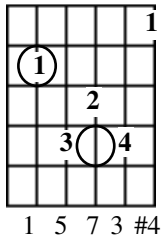

C ma7#11 nr II

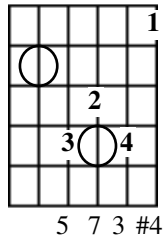

C ma7/6#11 IV

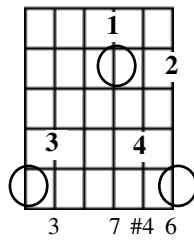

C ma7#11 V

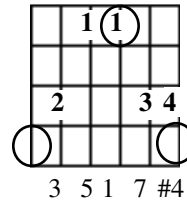

C ma7#11 VII

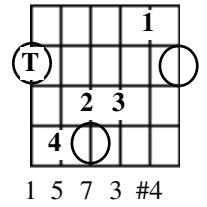

C ma7/6#11 VII

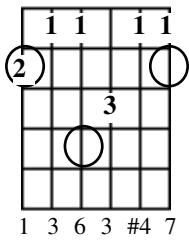

C ma7/6#11 VII

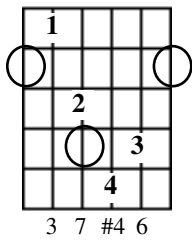

C ma7/6#11 VII

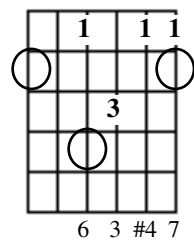

C ma7/6#11 VII

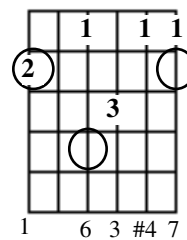

C ma7/6#11 IX

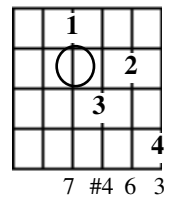

C ma7/6#11 IX

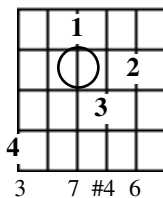

C ma7#11 X

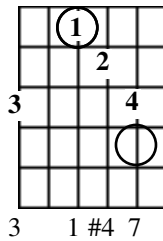

C ma7#11 X

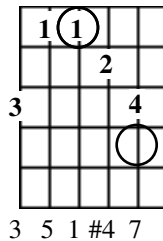

C ma7#11 nr XII

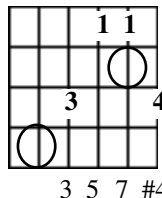

C ma7/6#11 XII

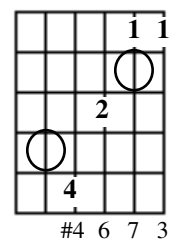

C ma7/6#11 XII

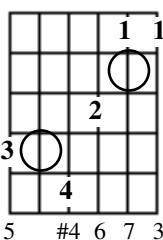

C ma7/6#11 XII

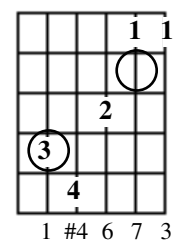

C ma7/6#11 XII

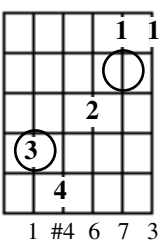

C ma7/6#11 XII

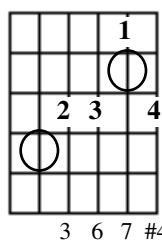

# major seventh add six add sharp eleven

C ma7/6#11 IV

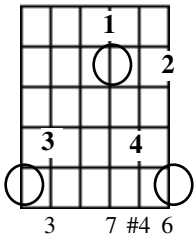

C ma7/6#11 VII

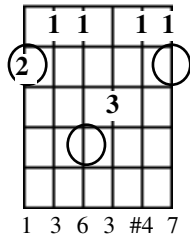

C ma7/6#11 VII

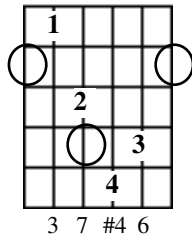

C ma7/6#11 VII

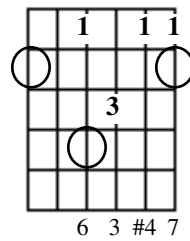

C ma7/6#11 VII

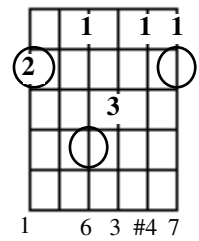

C ma7/6#11 IX

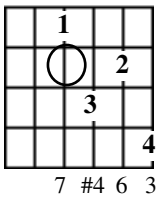

C ma7/6#11 IX

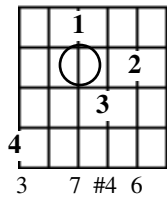

C ma7/6#11 XII

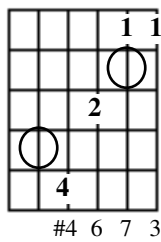

C ma7/6#11 XII

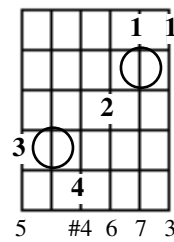

C ma7/6#11 XII

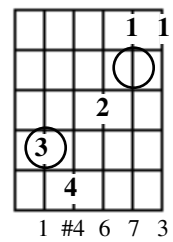

C ma7/6#11 XII

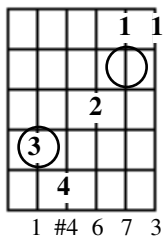

C ma7/6#11 XII

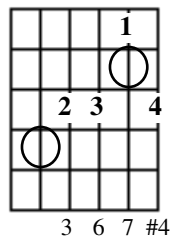

# major seventh add six flat five

C ma7/6b5 IV

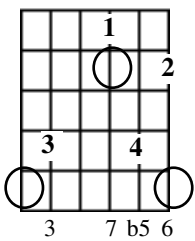

C ma7/6b5 VII

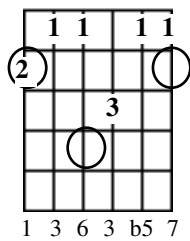

C ma7/6b5 VII

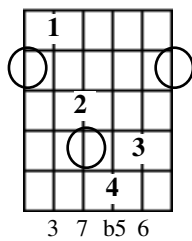

C ma7/6b5 VII

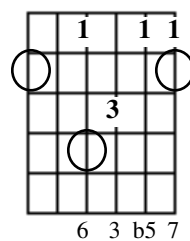

C ma7/6b5 VII

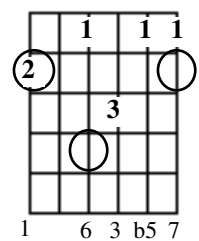

C ma7/6b5 IX

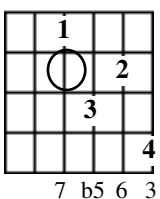

C ma7/6b5 IX

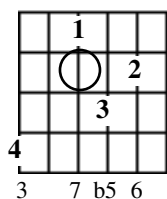

C ma7/6b5 XII

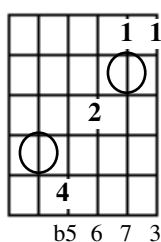

C ma7/6b5 XII

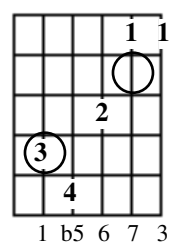

C ma7/6b5 XII

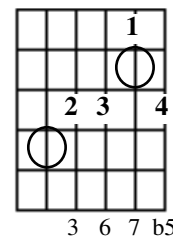

# major seventh suspended fourth

C ma7sus4 I

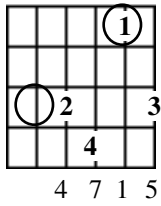

C ma7sus4 I

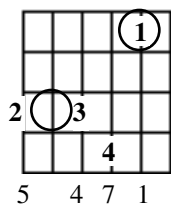

C ma7sus4 I

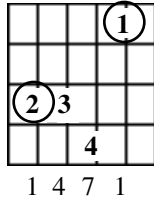

C ma7sus4 III

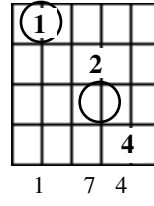

C ma7sus4 III

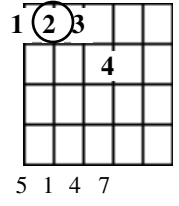

C ma7sus4 III

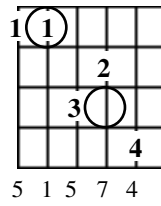

C ma7sus4 III

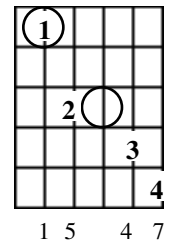

C ma7sus4 V

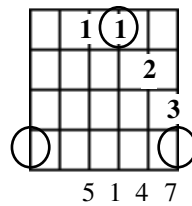

C ma7sus4 V

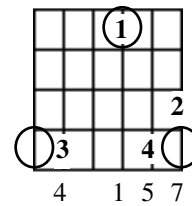

C ma7sus4 V

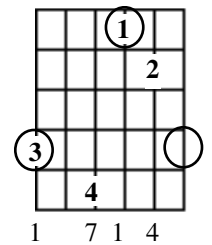

C ma7sus4 V

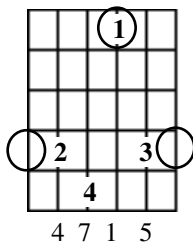

C ma7sus4 VII

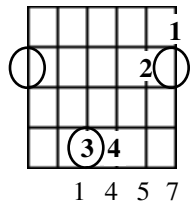

C ma7sus4 VII

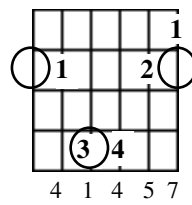

C ma7sus4 VII

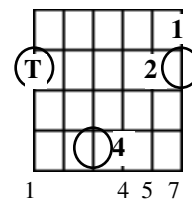

C ma7sus4 VII

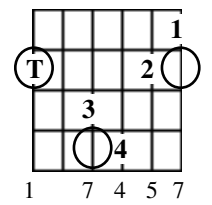

C ma7sus4 VII

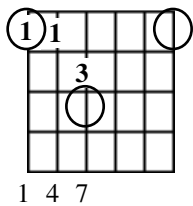

C ma7sus4 VIII

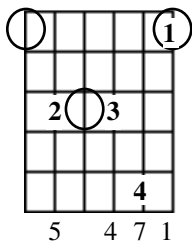

C ma7sus4 VIII

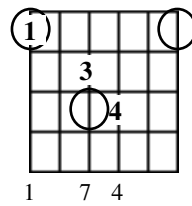

C ma7sus4 VIII

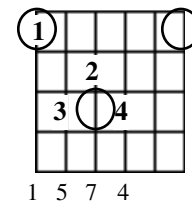

C ma7sus4 VIII

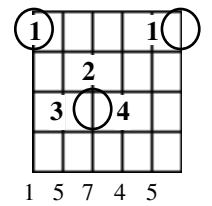

C ma7sus4 VIII

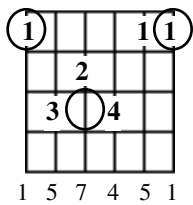

C ma7sus4 VIII

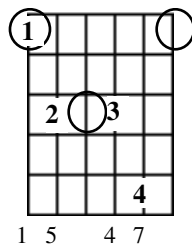

C ma7sus4 VIII

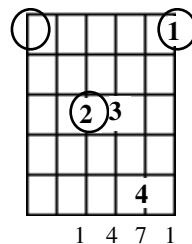

C ma7sus4 IX

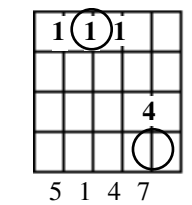

C ma7sus4 X

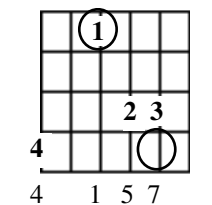

C ma7sus4 X

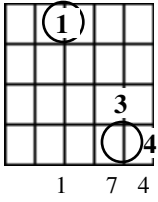

C ma7sus4 X

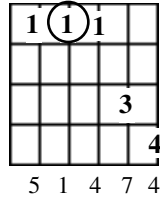

C ma7sus4 X

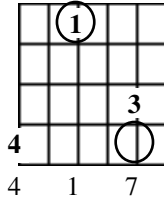

C ma7sus4 XII

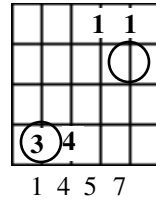

C ma7sus4 XII

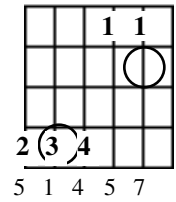

C ma7sus4 XII

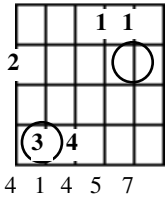

# major seventh suspended second

C ma7sus2 III  7 2	C ma7sus2 III  7 2 5	C ma7sus2 III  5 7 2	C ma7sus2 III  5 7 2 5	C ma7sus2 III  1 7 2
C ma7sus2 III  1 7 2 5	C ma7sus2 III  1 5 7 2	C ma7sus2 III  1 5 7 2 5	C ma7sus2 III  5 7 2	C ma7sus2 III  5 7 2 5
C ma7sus2 III  5 5 7 2	C ma7sus2 III  5 5 7 2 5	C ma7sus2 III  5 1 7 2	C ma7sus2 III  5 1 7 2 5	C ma7sus2 III  5 1 5 7 2
C ma7sus2 III  5 1 5 7 2 5	C ma7sus2 V  5 2 7	C ma7sus2 V  5 2 5 7	C ma7sus2 V  1 5 2 7	C ma7sus2 VII  2 7
C ma7sus2 VII  1 2 7	C ma7sus2 VII  2 5 7	C ma7sus2 VII  1 2 5 7	C ma7sus2 VII  5 1 2 7	C ma7sus2 VII  5 2 5 7

C ma7sus2 VII

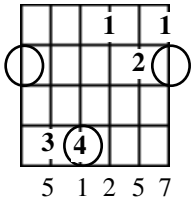

C ma7sus2 VII

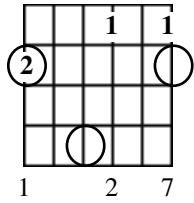

C ma7sus2 VII

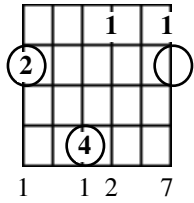

C ma7sus2 VII

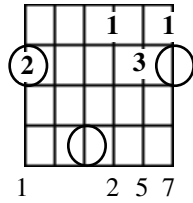

C ma7sus2 VII

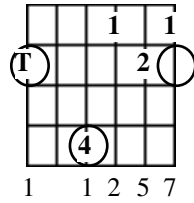

C ma7sus2 VII

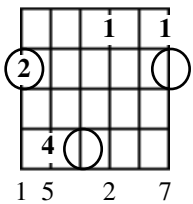

C ma7sus2 VII

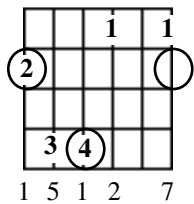

C ma7sus2 VII

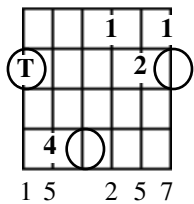

C ma7sus2 VII

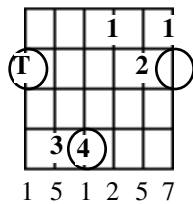

C ma7sus2 VII

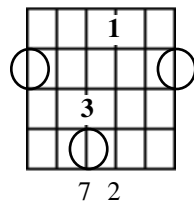

C ma7sus2 VII

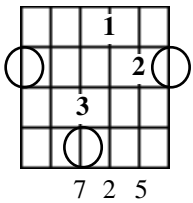

C ma7sus2 VII

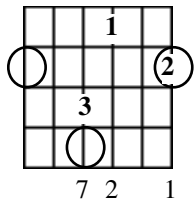

C ma7sus2 VII

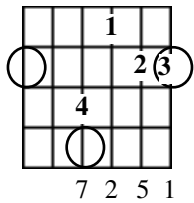

C ma7sus2 VII

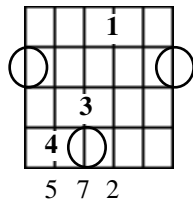

C ma7sus2 VII

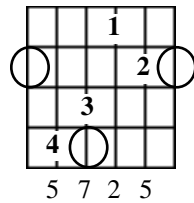

C ma7sus2 VII

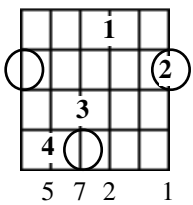

C ma7sus2 VII

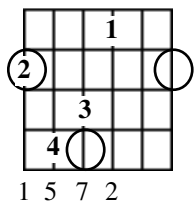

C ma7sus2 VII

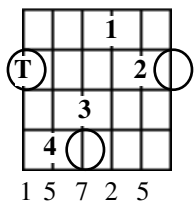

C ma7sus2 VII

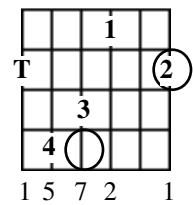

C ma7sus2 VII

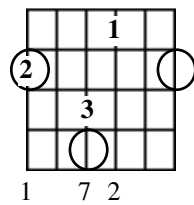

C ma7sus2 VII

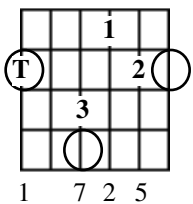

C ma7sus2 VII

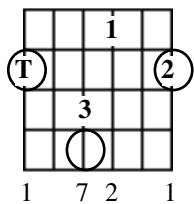

C ma7sus2 VIII

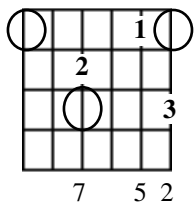

C ma7sus2 VIII

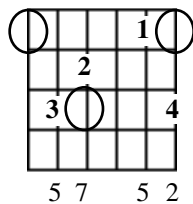

C ma7sus2 VIII

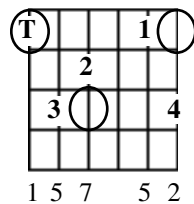

C ma7sus2 IX

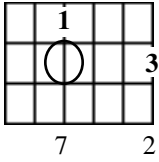

C ma7sus2 IX

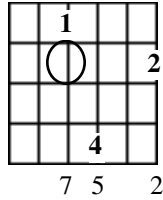

C ma7sus2 IX

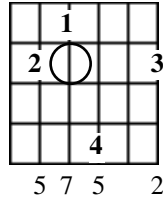

C ma7sus2 X

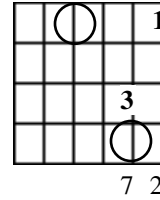

C ma7sus2 X

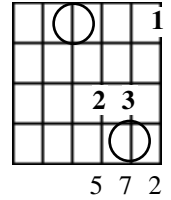

C ma7sus2 X

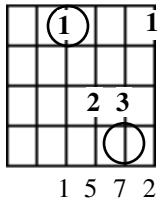

C ma7sus2 X

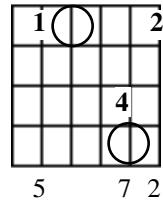

C ma7sus2 X

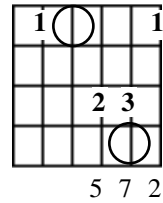

C ma7sus2 X

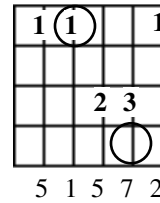

C ma7sus2 XII

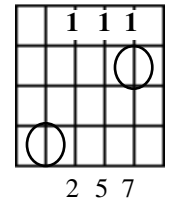

C ma7sus2 XII

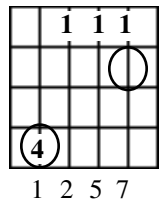

C ma7sus2 XII

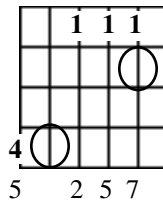

C ma7sus2 XII

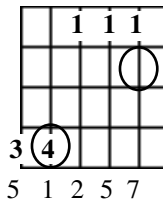

## major seventh flat five

C ma7b5 III

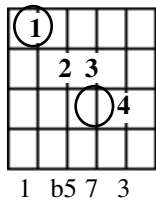

C ma7b5 X

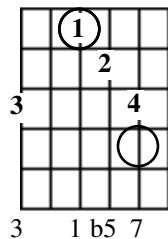



# major seventh sharp five

C ma7#5 I	C ma7#5 II	C ma7#5 III	C ma7#5 III	C ma7#5 III
C ma7#5 IV	C ma7#5 V	C ma7#5 V	C ma7#5 V	C ma7#5 V
C ma7#5 VII	C ma7#5 VII	C ma7#5 VII	C ma7#5 VII	C ma7#5 VIII
C ma7#5 VIII	C ma7#5 VIII	C ma7#5 VIII	C ma7#5 VIII	C ma7#5 VIII
C ma7#5 IX	C ma7#5 X	C ma7#5 X	C ma7#5 XII	C ma7#5 XII

C ma7#5 XII

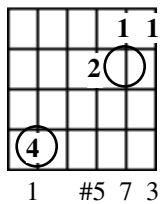

C ma7#5 XII

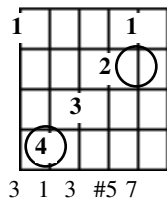

# major seventh add six flat 5

C ma7/6b5 IV

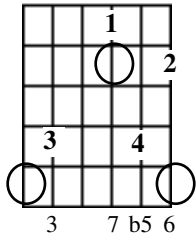

C ma7/6b5 VII

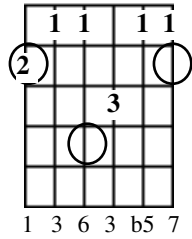

C ma7/6b5 VII

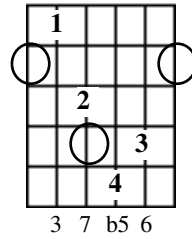

C ma7/6b5 VII

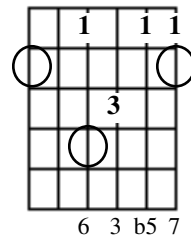

C ma7/6b5 VII

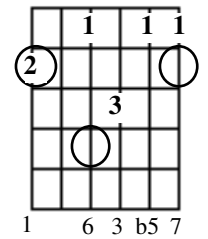

C ma7/6b5 IX

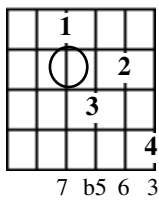

C ma7/6b5 IX

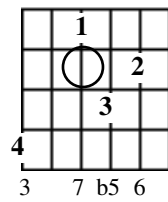

C ma7/6b5 XII

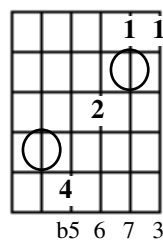

C ma7/6b5 XII

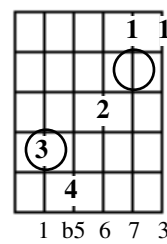

C ma7/6b5 XII

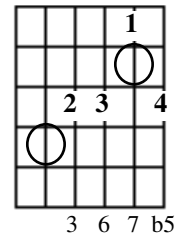

# major ninth

C ma9 nr I

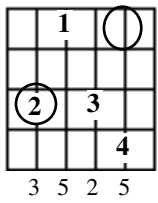

C ma9 II

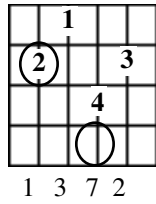

C ma9 nr II

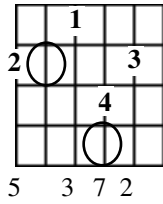

C ma9 nr II

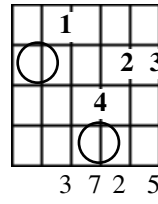

C ma9 II

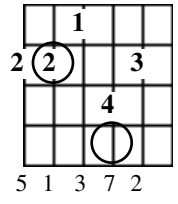

C ma9 nr III

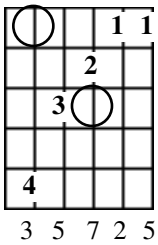

C ma9 nr III

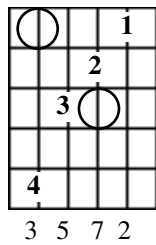

C ma9 nr V

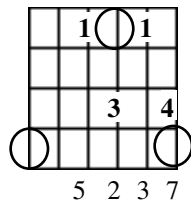

C ma9 nr V

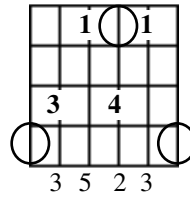

C ma9 nr V

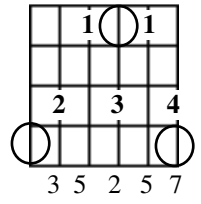

C ma9 V

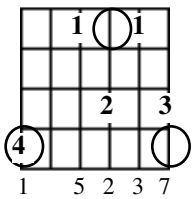

C ma9 V

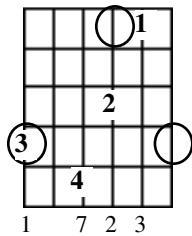

C ma9 VII

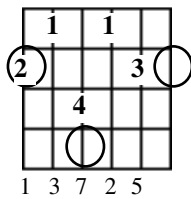

C ma9 VII

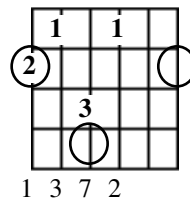

C ma9 nr VII

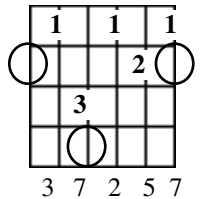

C ma9 nr VII

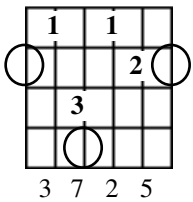

C ma9 nr VII

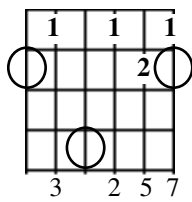

C ma9 VIII

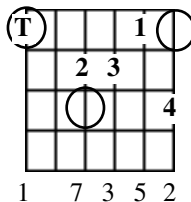

C ma9 nr VIII

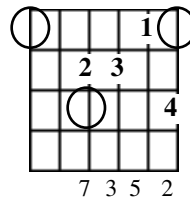

C ma9 IX

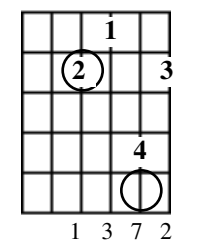

C ma9 nr IX

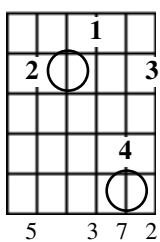

C ma9 nr IX

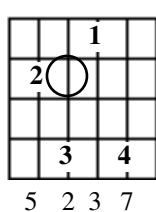

C ma9 X

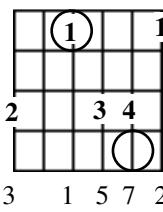

C ma9 XII

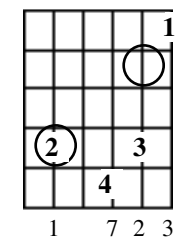



C ma9n3 VII

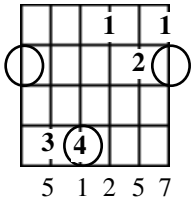

C ma9n3 VII

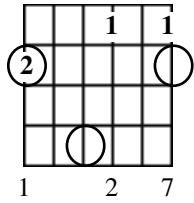

C ma9n3 VII

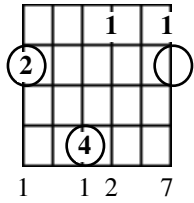

C ma9n3 VII

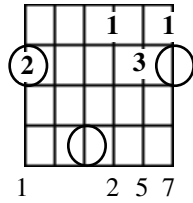

C ma9n3 VII

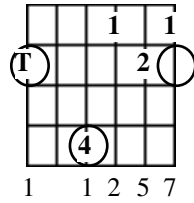

C ma9n3 VII

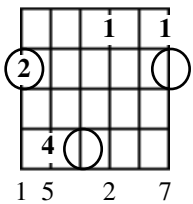

C ma9n3 VII

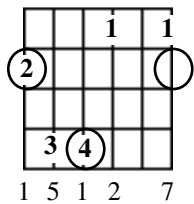

C ma9n3 VII

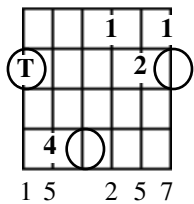

C ma9n3 VII

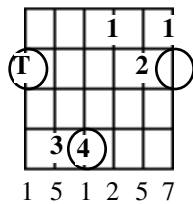

C ma9n3 nr VII

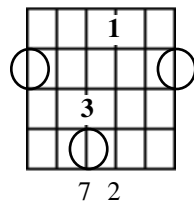

C ma9n3 nr VII

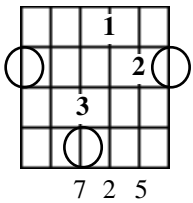

C ma9n3 VII

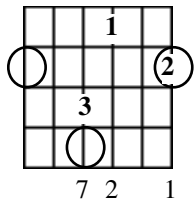

C ma9n3 VII

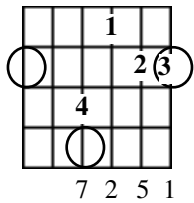

C ma9n3 nr VII

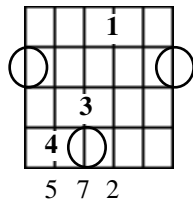

C ma9n3 nr VII

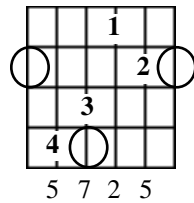

C ma9n3 VII

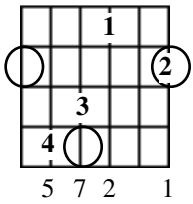

C ma9n3 VII

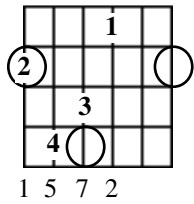

C ma9n3 VII

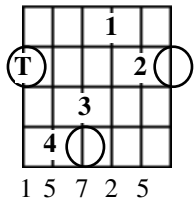

C ma9n3 VII

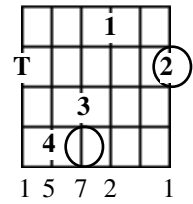

C ma9n3 VII

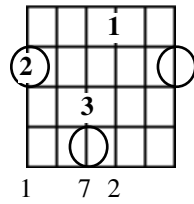

C ma9n3 VII

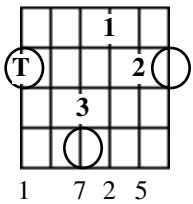

C ma9n3 VII

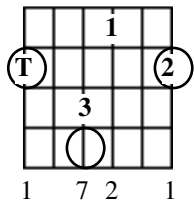

C ma9n3 nr VIII

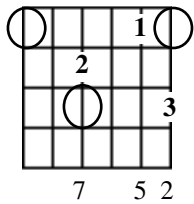

C ma9n3 nr VIII

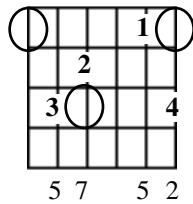

C ma9n3 VIII

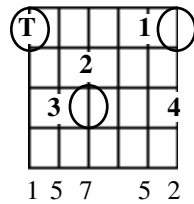

C ma9n3 nr IX

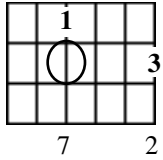

C ma9n3 nr IX

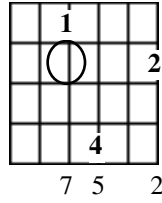

C ma9n3 nr IX

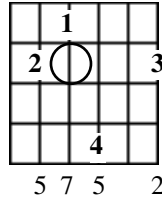

C ma9n3 nr X

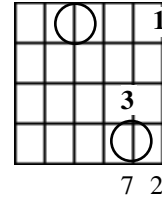

C ma9n3 nr X

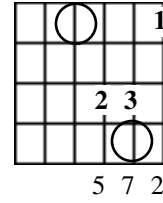

C ma9n3 X

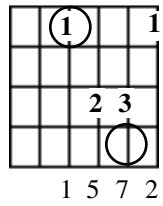

C ma9n3 nr X

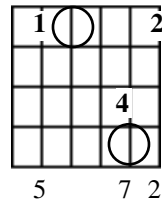

C ma9n3 nr X

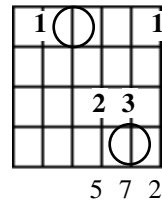

C ma9n3 X

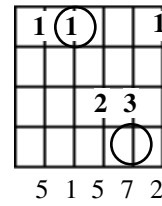

C ma9n3 nr XII

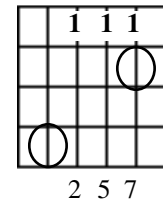

C ma9n3 XII

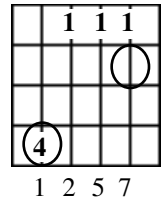

C ma9n3 nr XII

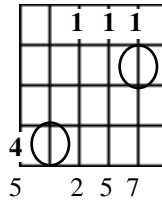

C ma9n3 XII

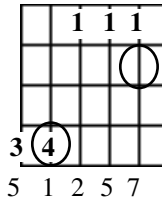

# major ninth add six

C ma9/6 nr II

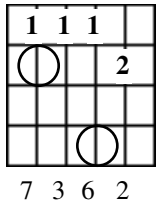

C ma9/6 nr II

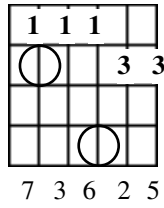

C ma9/6 VII

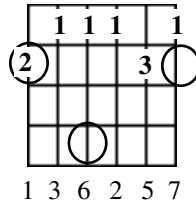

C ma9/6 nr VII

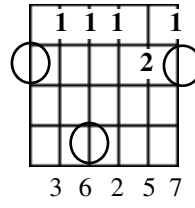

C ma9/6 nr VII

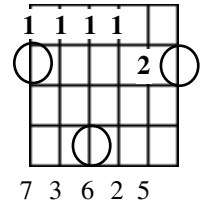

C ma9/6 VIII

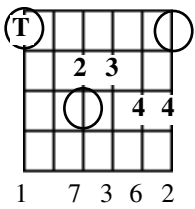

C ma9/6 VIII

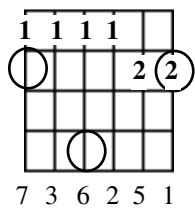

C ma9/6 nr XII

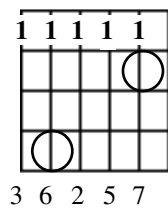





# major ninth flat five

C ma9b5 II

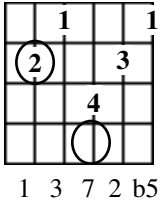

C ma9b5 VII

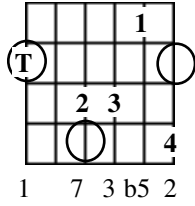

C ma9b5 VII

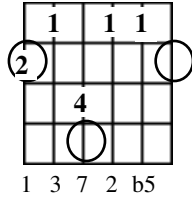

C ma9b5 IX

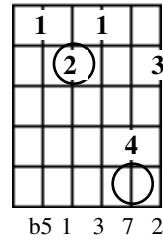

C ma9b5 X

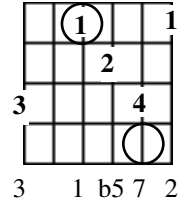

# major ninth sharp five

C ma9#5 nr III

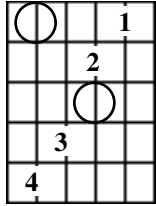

3 #5 7 2

C ma9#5 nr III

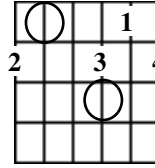

#5 7 2 #5

C ma9#5 nr V

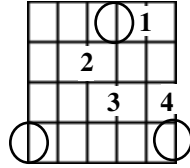

#5 2 3 7

C ma9#5 VII

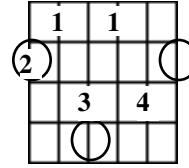

1 3 7 2 #5

C ma9#5 nr VII

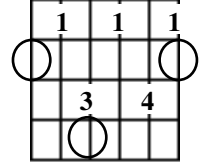

3 7 2 #5 7

C ma9#5 nr VII

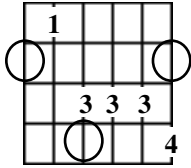

3 7 3 #5 2

C ma9#5 nr VII

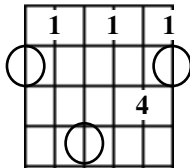

3 2 #5 7

C ma9#5 VIII

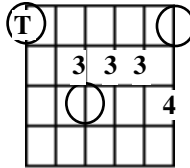

1 7 3 #5 2

C ma9#5 nr IX

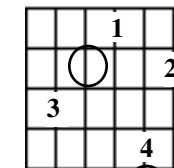

#5 3 7 2

C ma9#5 nr IX

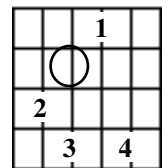

#5 2 3 7

C ma9#5 nr X

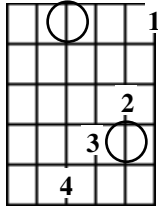

3 #5 7 2

C ma9#5 nr X

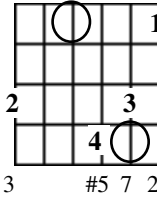

3 #5 7 2

C ma9#5 nr XII

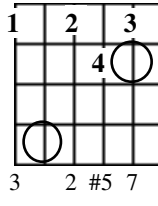

3 2 #5 7

C ma9#5 nr XII

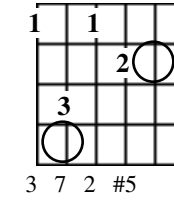

3 7 2 #5

C ma9#5 nr XII

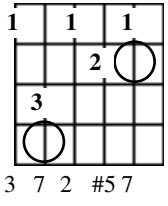

3 7 2 #5 7

# major thirteenth sharp eleven

C ma13#11 IV

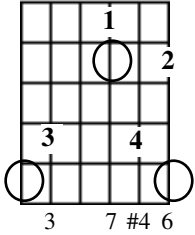

C ma13#11 VII

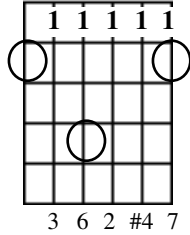

C ma13#11 VII

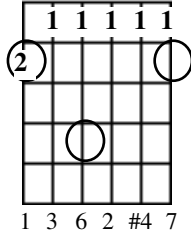

C ma13#11 VII

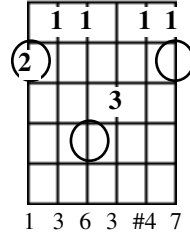

C ma13#11 VII

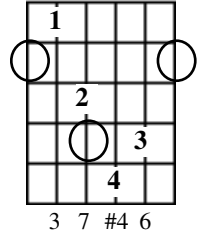

C ma13#11 VII

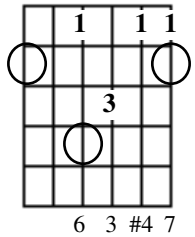

C ma13#11 VII

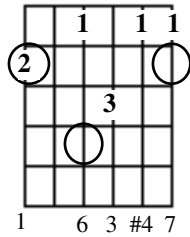

C ma13#11 IX

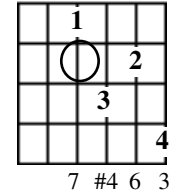

C ma13#11 IX

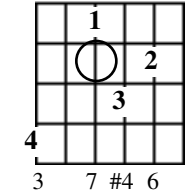

C ma13#11 XII

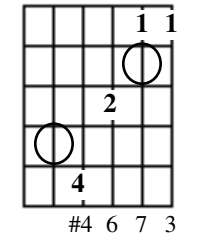

C ma13#11 XII

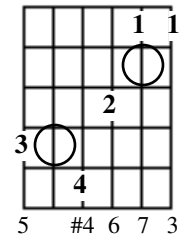

C ma13#11 XII

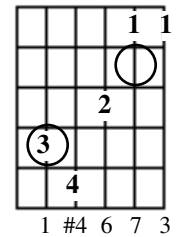

C ma13#11 XII

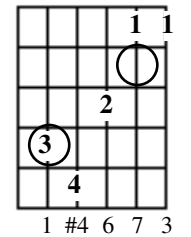

C ma13#11 XII

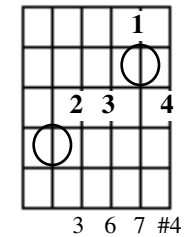

# sixth

C6 I 	C6 I 	C6 I 	C6 I 	C6 I 
C6 II 	C6 II 	C6 nr II 	C6 II 	C6 II 
C6 III 	C6 V 	C6 V 	C6 V 	C6 V 
C6 V 	C6 V 	C6 nr V 	C6 nr V 	C6 V 
C6 V 	C6 V 	C6 VII 	C6 VII 	C6 VII 

C 6 VII

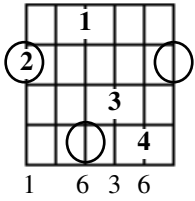

C 6 VIII

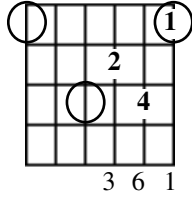

C 6 VIII

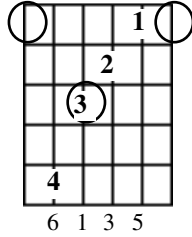

C 6 VIII

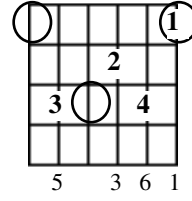

C 6 IX

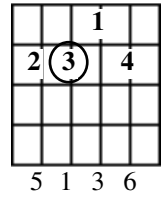

C 6 IX

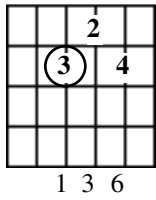

C 6 nr IX

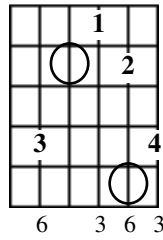

C 6 IX

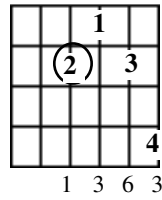

C 6 X

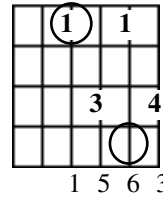

C 6 nr X

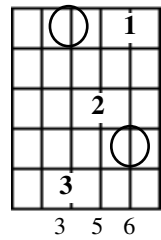

C 6 X

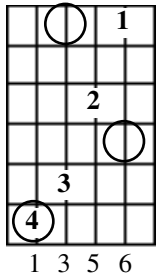

C 6 X

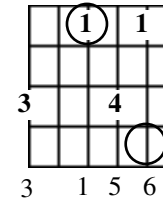

C 6 XII

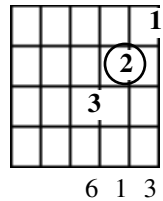

C 6 XII

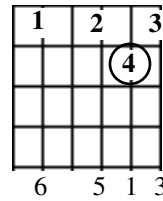

C 6 XII

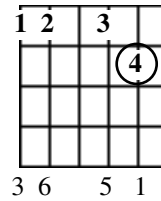

C 6 XII

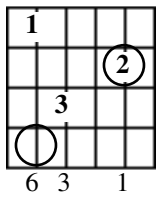

C 6 nr XII

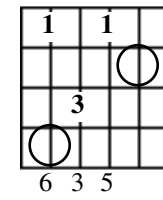

C 6 XII

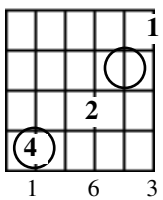

# sixth add nine

C 6/9 II	C 6/9 nr II	C 6/9 II	C 6/9 nr II	C 6/9 II
3 6 2	3 6 2 5	1 3 6 2 5	5 3 6 2	5 1 3 6 2
C 6/9 II	C 6/9 nr II	C 6/9 II	C 6/9 II	C 6/9 nr III
5 1 3 6 2 5	3 2 6	3 1 2 6	1 3 2 6	3 6 2
C 6/9 nr III	C 6/9 III	C 6/9 III	C 6/9 III	C 6/9 III
3 6 2 5	3 6 1 2 5	3 6 1 2	5 3 6 1 2	5 3 6 1 2 5
C 6/9 nr III	C 6/9 III	C 6/9 III	C 6/9 nr V	C 6/9 nr V
3 2 6	3 1 2 6	5 3 1 2 6	2 3 6	5 2 3 6
C 6/9 nr V	C 6/9 V	C 6/9 V	C 6/9 V	C 6/9 nr V
3 5 2 3 6	1 3 5 2 3 6	1 2 3 6	1 5 2 3 6	6 2 3

C 6/9 nr V

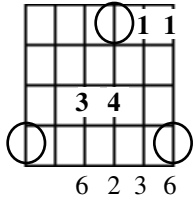

C 6/9 V

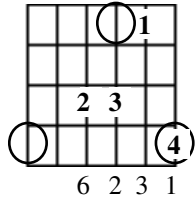

C 6/9 nr V

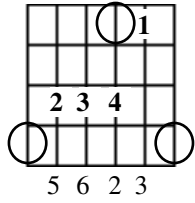

C 6/9 V

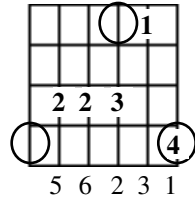

C 6/9 V

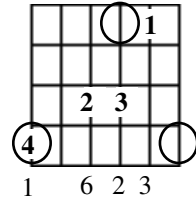

C 6/9 V

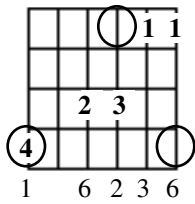

C 6/9 VII

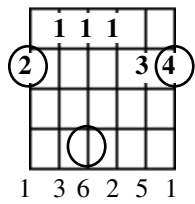

C 6/9 VII

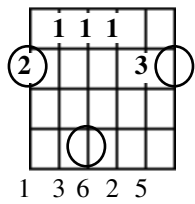

C 6/9 VII

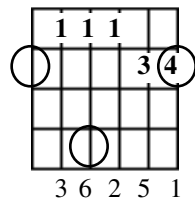

C 6/9 nr VII

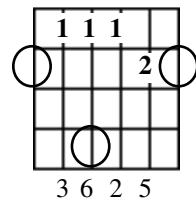

C 6/9 nr VII

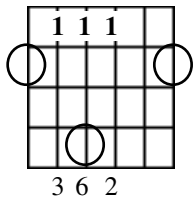

C 6/9 VII

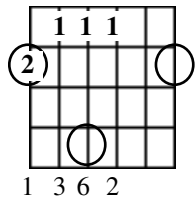

C 6/9 VII

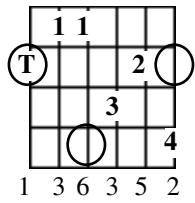

C 6/9 nr VII

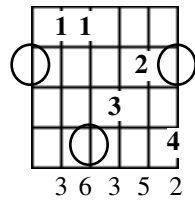

C 6/9 nr VII

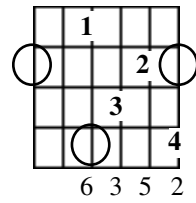

C 6/9 VII

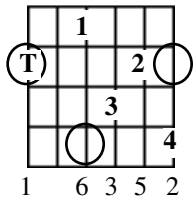

C 6/9 VII

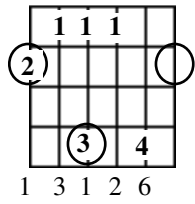

C 6/9 VII

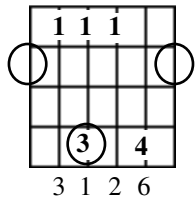

C 6/9 VII

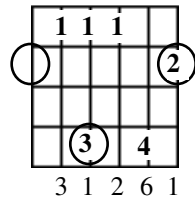

C 6/9 nr VII

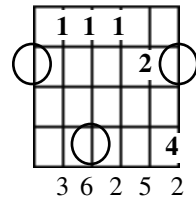

C 6/9 VII

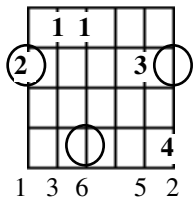

C 6/9 nr VII

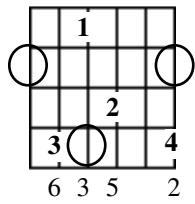

C 6/9 nr VII

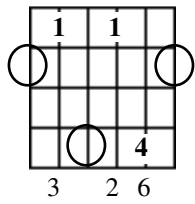

C 6/9 VII

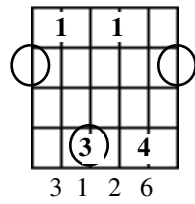

C 6/9 VII

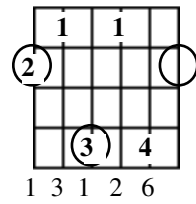



C 6/9 VII

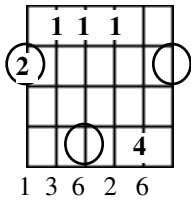

C 6/9 nr VII

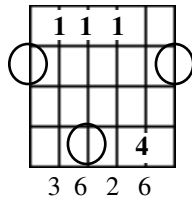

C 6/9 VII

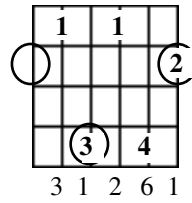

C 6/9 VIII

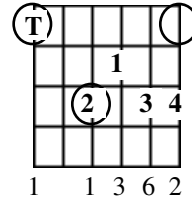

C 6/9 VIII

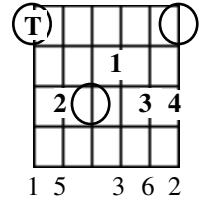

C 6/9 nr VIII

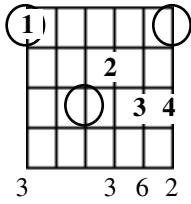

C 6/9 VIII

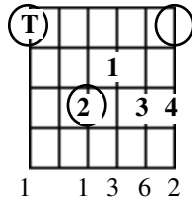

C 6/9 VIII

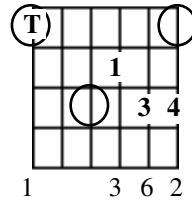

C 6/9 VIII

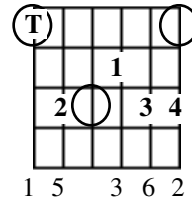

C 6/9 VIII

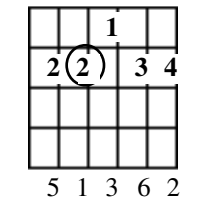

C 6/9 VIII

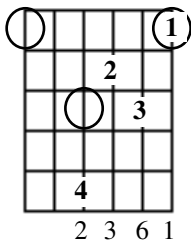

C 6/9 VIII

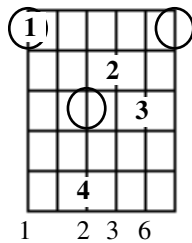

C 6/9 IX

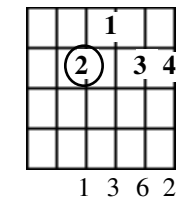

C 6/9 nr IX

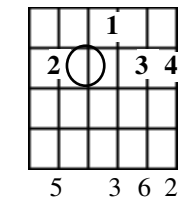

C 6/9 nr IX

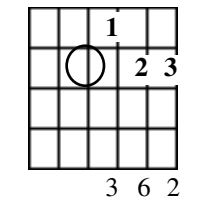

C 6/9 IX

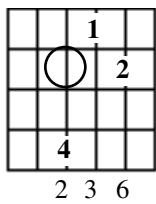

C 6/9 nr IX

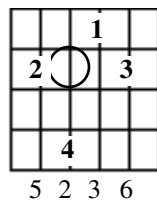

C 6/9 nr X

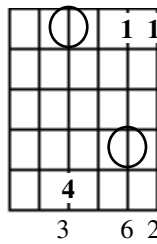

C 6/9 nr X

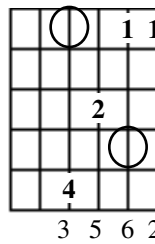

C 6/9 X

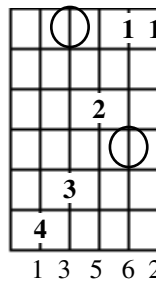

C 6/9 X

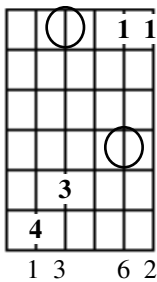

C 6/9 nr X

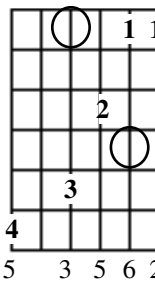

C 6/9 nr X

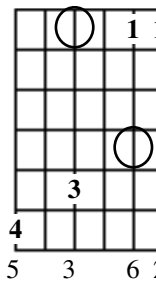

C 6/9 nr X

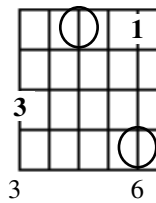

C 6/9 nr X

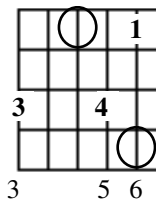

C 6/9 X

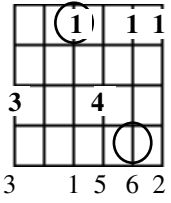

C 6/9 X

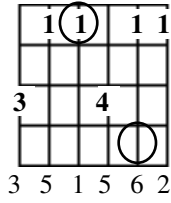

C 6/9 nr X

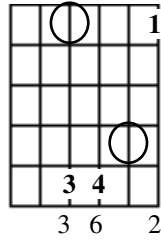

C 6/9 X

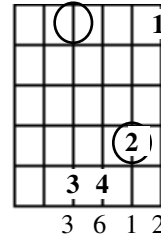

C 6/9 X

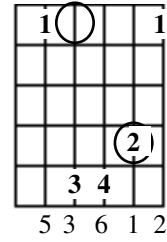

C 6/9 nr XII

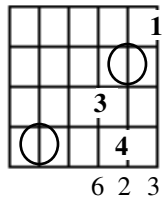

C 6/9 nr XII

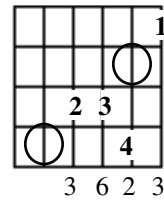

C 6/9 XII

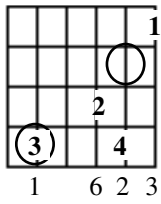

C 6/9 nr XII

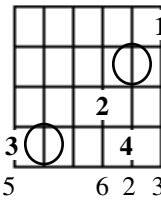

# sixth add nine sharp eleven

C 6/9#11 II

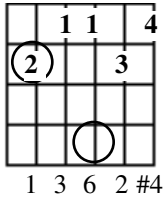

C 6/9#11 nr II

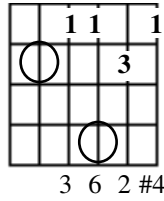

C 6/9#11 II

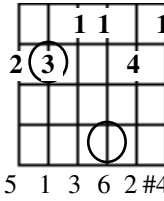

C 6/9#11 II

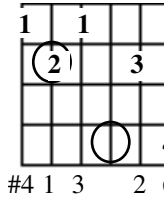

C 6/9#11 nr IV

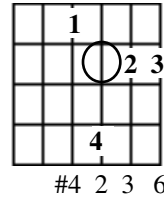

C 6/9#11 nr V

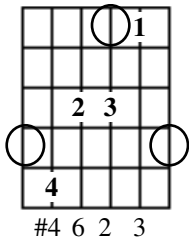

C 6/9#11 nr V

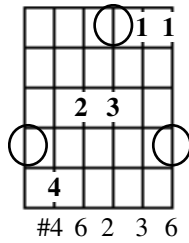

C 6/9#11 nr VII

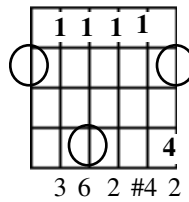

C 6/9#11 VII

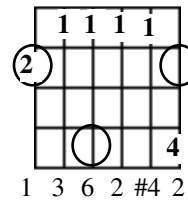

C 6/9#11 VII

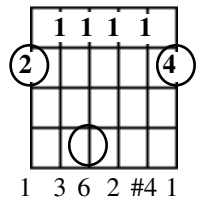

C 6/9#11 VII

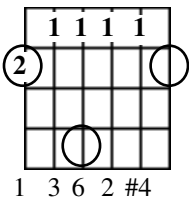

C 6/9#11 VII

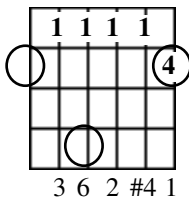

C 6/9#11 nr VII

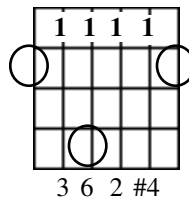

C 6/9#11 VII

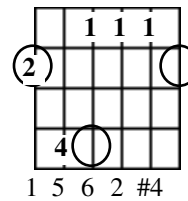

C 6/9#11 nr VII

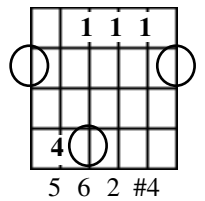

C 6/9#11 VII

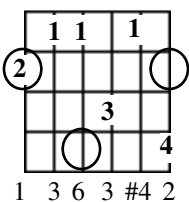

C 6/9#11 nr VII

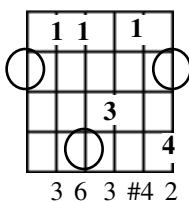

C 6/9#11 VII

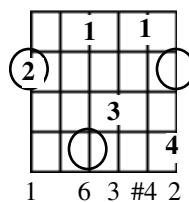

C 6/9#11 nr VII

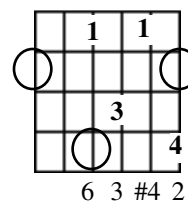

C 6/9#11 nr VII

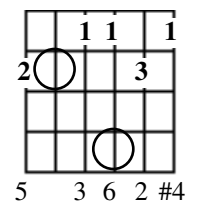

C 6/9#11 nr VIII

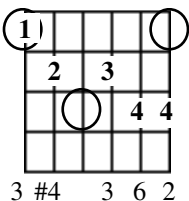

C 6/9#11 VIII

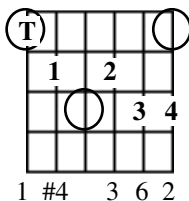

C 6/9#11 IX

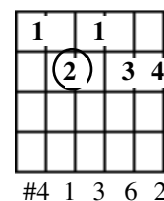

C 6/9#11 nr IX

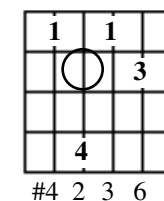

C 6/9#11 nr X

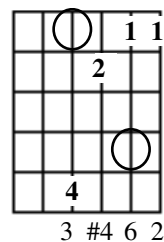

C 6/9#11 nr X

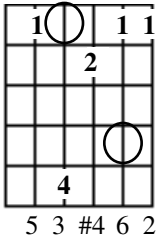

C 6/9#11 X

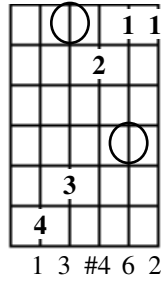

C 6/9#11 nr X

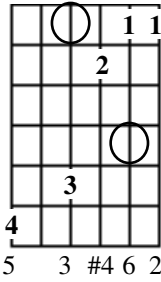

C 6/9#11 nr X

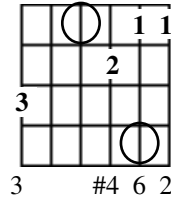

C 6/9#11 X

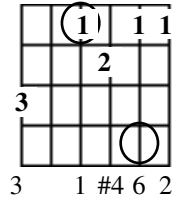

C 6/9#11 X

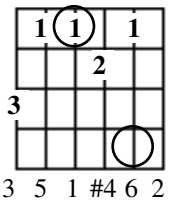

C 6/9#11 nr X

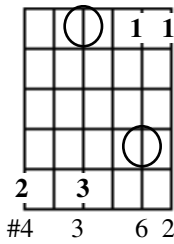

C 6/9#11 nr XII

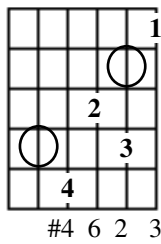

# sixth add nine flat five

C 6/9b5 II

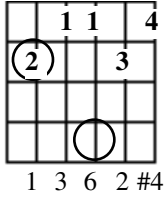

C 6/9b5 nr II

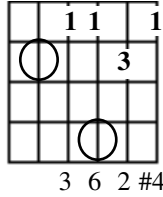

C 6/9b5 II

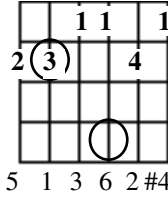

C 6/9b5 II

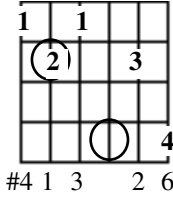

C 6/9b5 nr IV

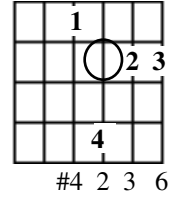

C 6/9b5 nr VII

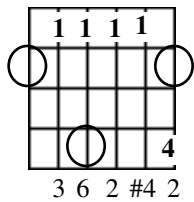

C 6/9b5 VII

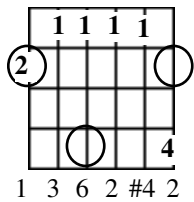

C 6/9b5 VII

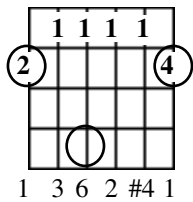

C 6/9b5 VII

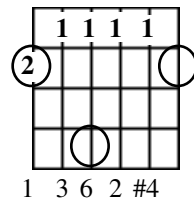

C 6/9b5 VII

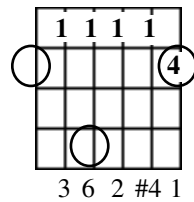

C 6/9b5 nr VII

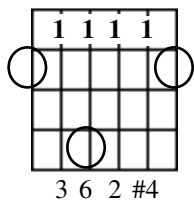

C 6/9b5 VII

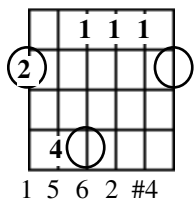

C 6/9b5 nr VII

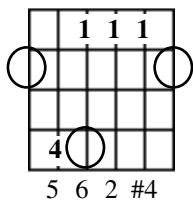

C 6/9b5 VII

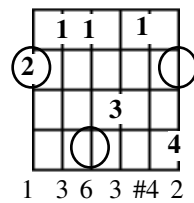

C 6/9b5 nr VII

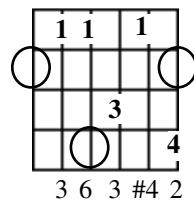

C 6/9b5 VII

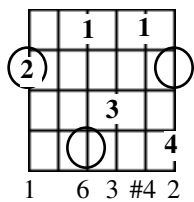

C 6/9b5 nr VII

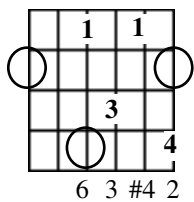

C 6/9b5 nr VII

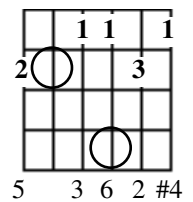

C 6/9b5 nr VIII

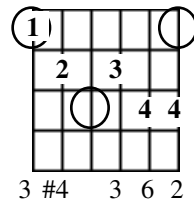

C 6/9b5 IX

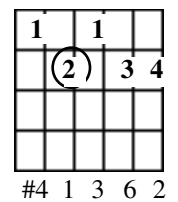

C 6/9b5 nr IX

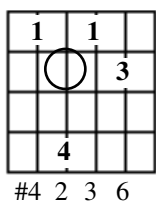

C 6/9b5 nr X

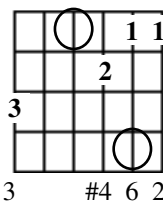

C 6/9b5 X

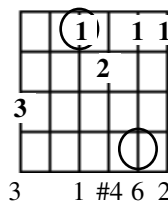

C 6/9b5 X

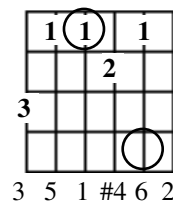

# add nine

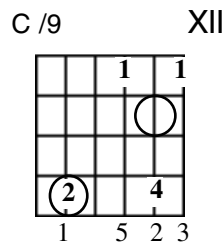
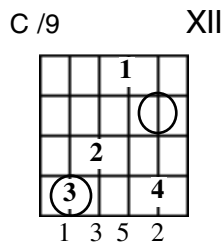
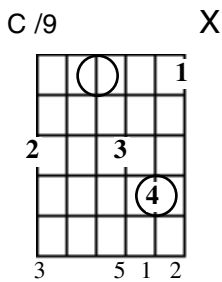
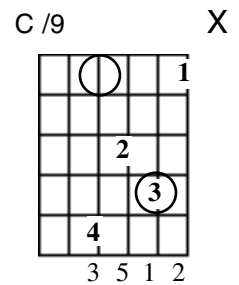
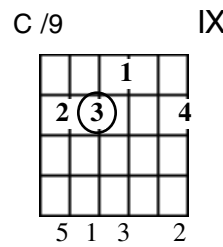
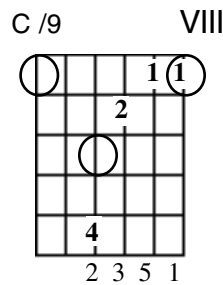
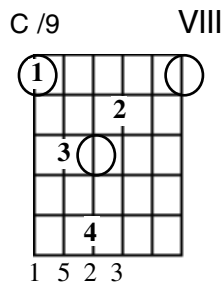
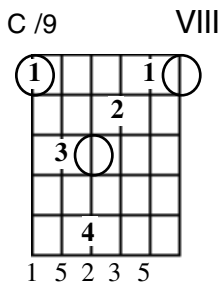
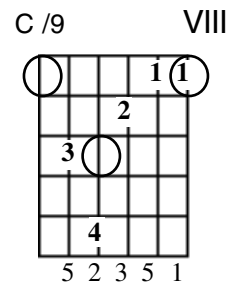
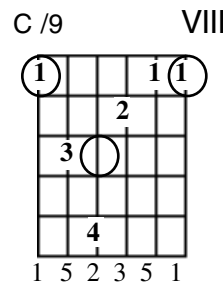
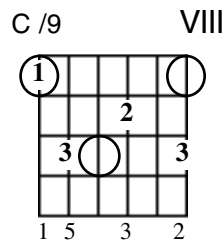
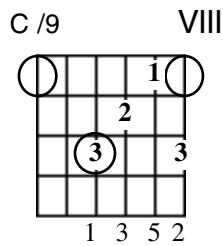
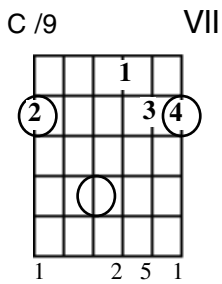
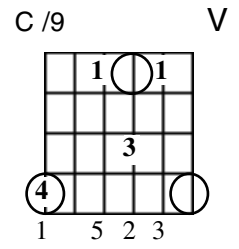
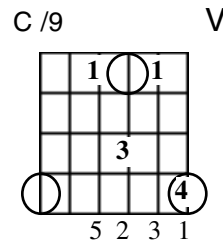
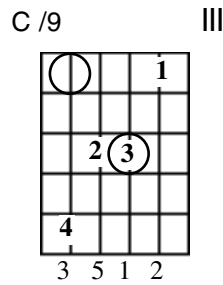
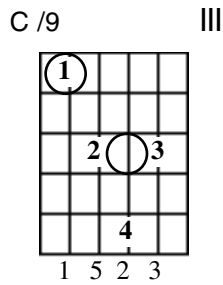
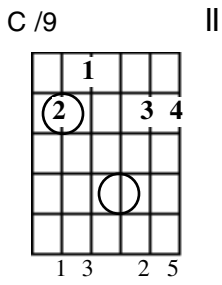

# dominant seventh

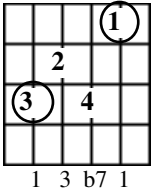
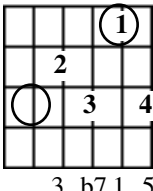
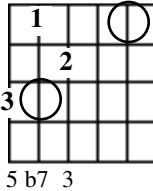
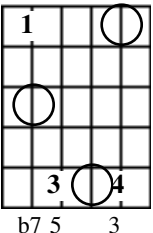
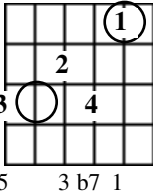
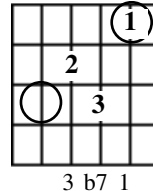
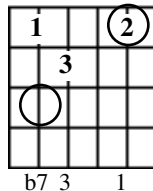
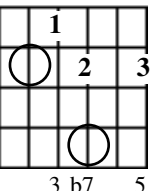
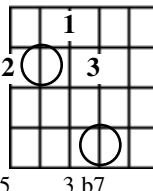
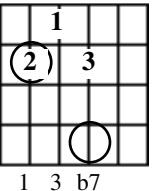
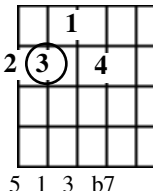
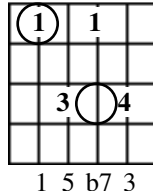
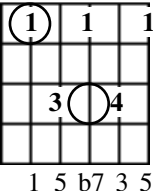
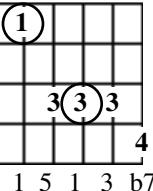
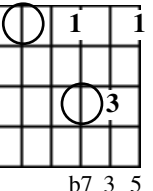
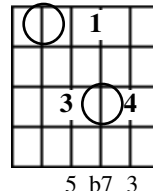
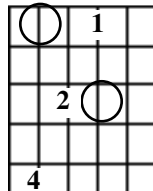
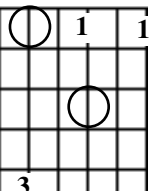
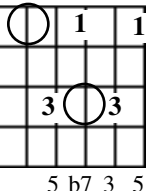
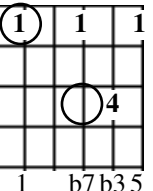
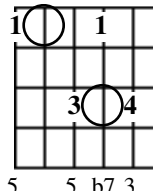
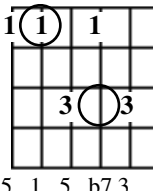
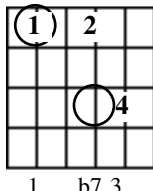
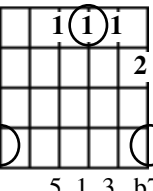
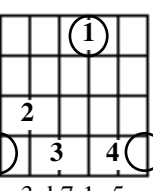
C7 I 	C7 I 	C7 nr I 	C7 nr I 	C7 I 
C7 I 	C7 I 	C7 nr II 	C7 nr II 	C7 II 
C7 II 	C7 III 	C7 III 	C7 III 	C7 nr III 
C7 nr III 	C7 nr III 	C7 nr III 	C7 nr III 	C7 III 
C7 nr III 	C7 III 	C7 III 	C7 V 	C7 V 

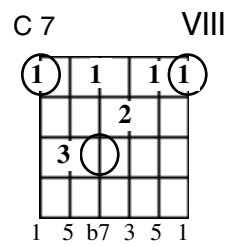
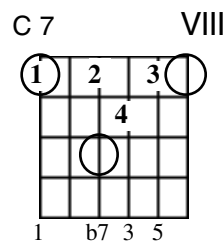
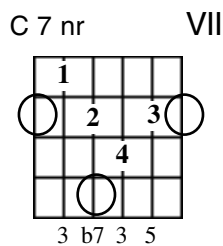
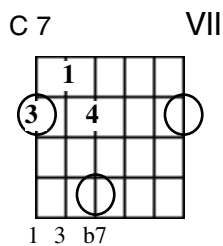
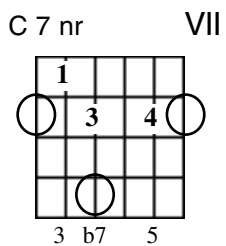
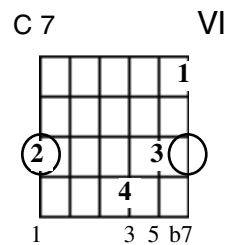
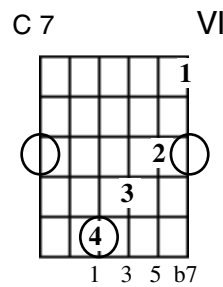
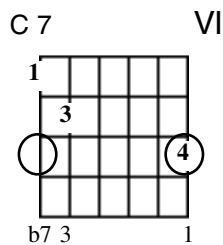
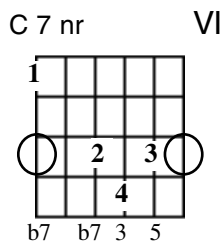
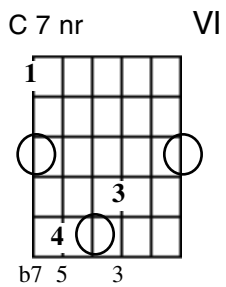
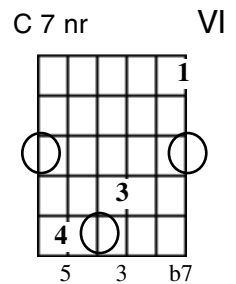
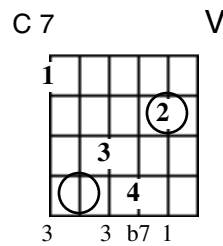
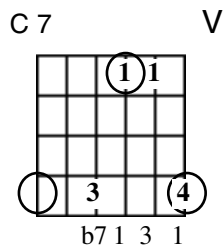
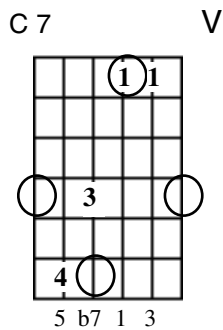
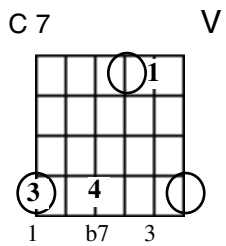
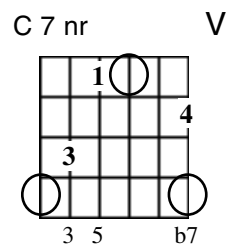
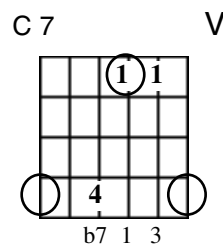
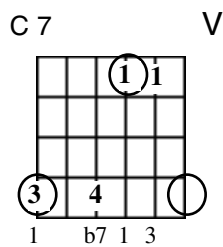
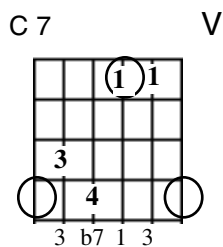
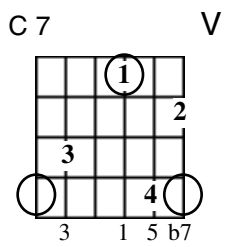
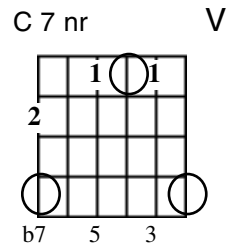
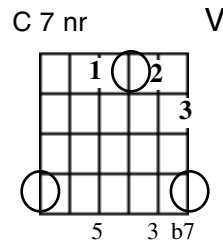
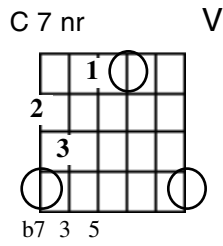
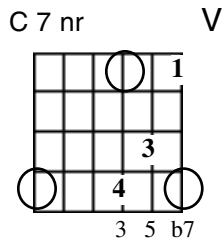
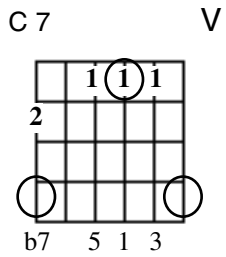



C 7 VIII

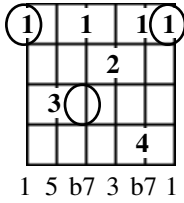

C 7 VIII

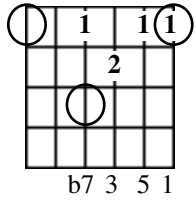

C 7 nr VIII

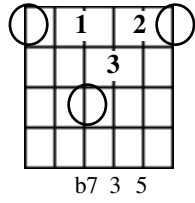

C 7 nr VIII

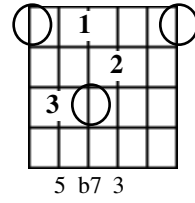

C 7 nr VIII

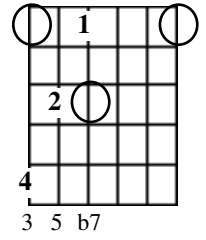

C 7 nr VIII

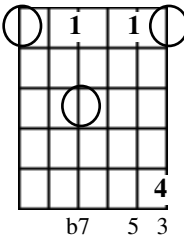

C 7 nr VIII

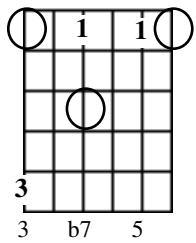

C 7 nr VIII

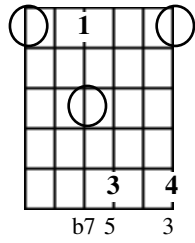

C 7 nr VIII

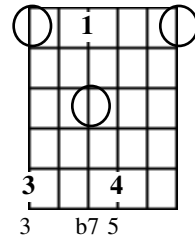

C 7 nr VIII

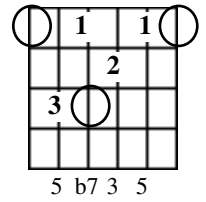

C 7 VIII

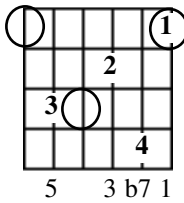

C 7 VIII

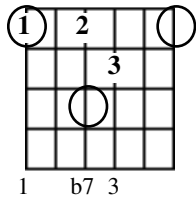

C 7 VIII

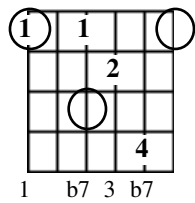

C 7 VIII

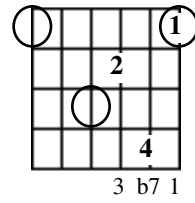

C 7 VIII

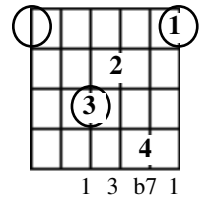

C 7 VIII

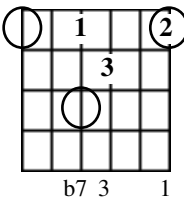

C 7 VIII

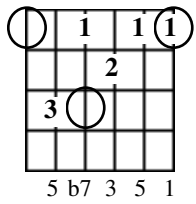

C 7 VIII

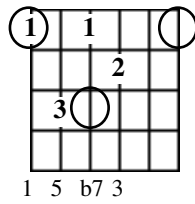

C 7 VIII

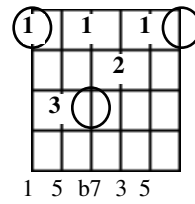

C 7 IX

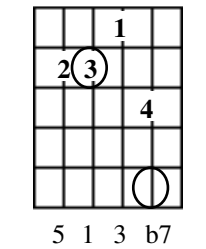

C 7 nr IX

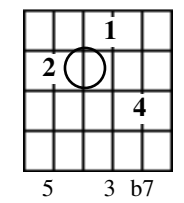

C 7 IX

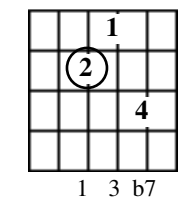

C 7 X

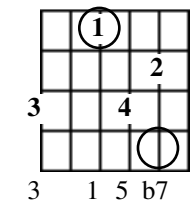

C 7 nr X

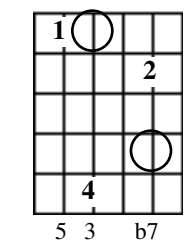

C 7 X

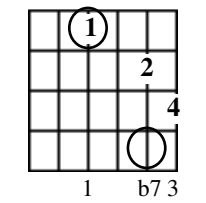

C 7 X

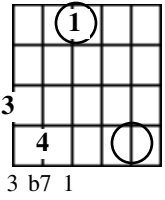

C 7 nr XI

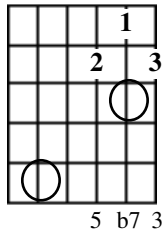

C 7 nr XI

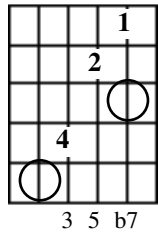

C 7 nr XI

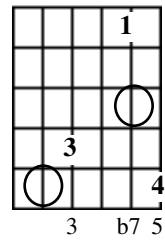

C 7 nr XI

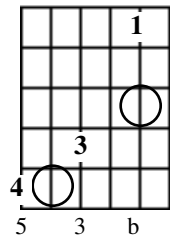

C 7 XI

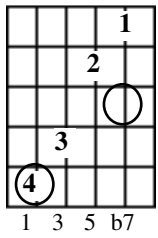

C 7 nr XI

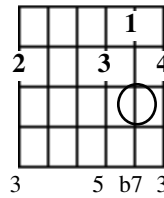

C 7 XII

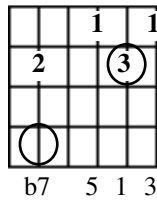

C 7 nr XII

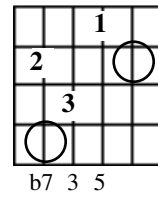

C 7 nr XII

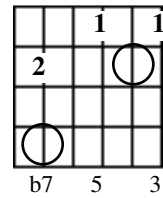

C 7 nr XII

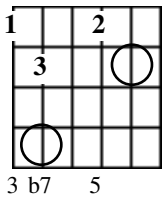

C 7 XII

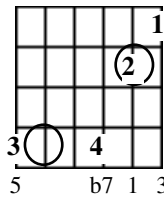

C 7 XII

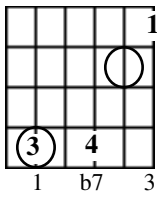

C 7 XII

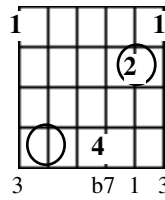

# dominant seventh no third

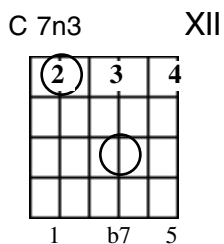
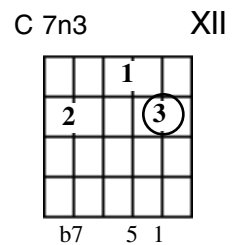
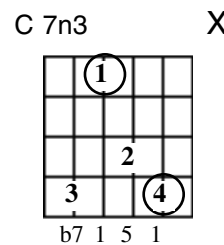
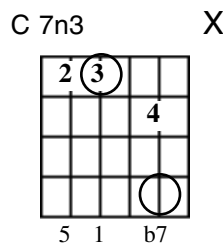
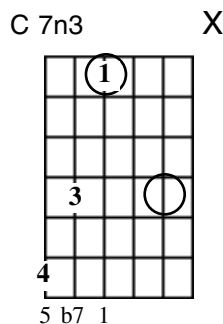
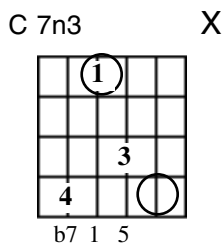
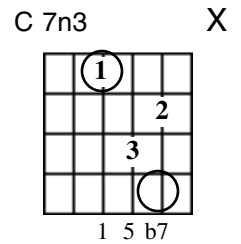
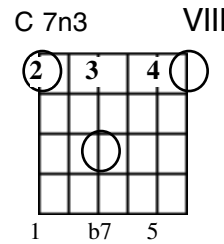
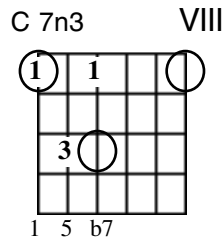
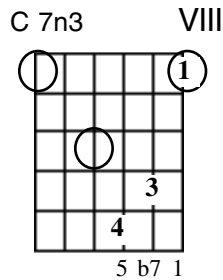
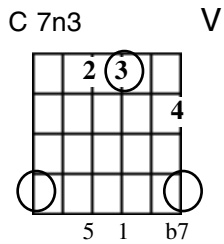
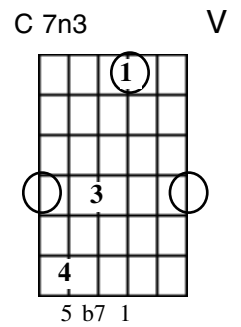
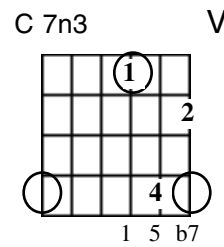
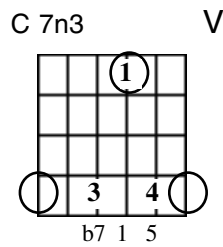
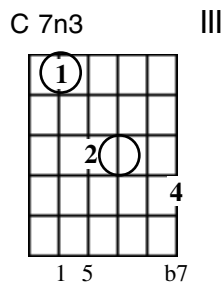
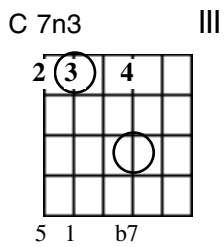
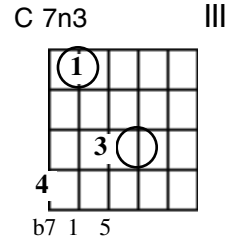
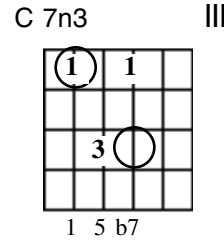
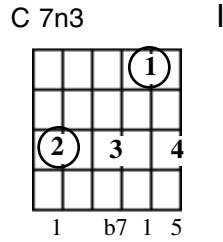
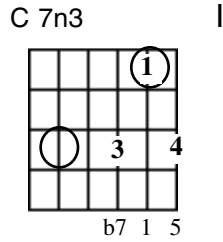
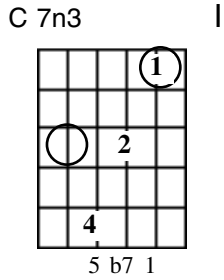

# dominant seventh add six

C 7/6 I

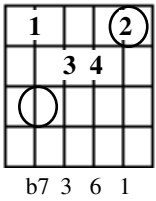

C 7/6 nr I

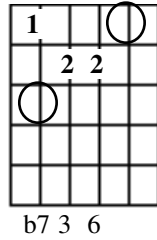

C 7/6 nr I

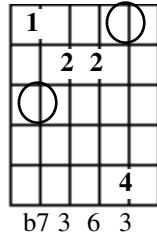

C 7/6 I

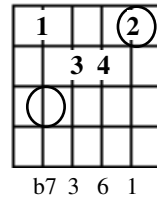

C 7/6 nr I

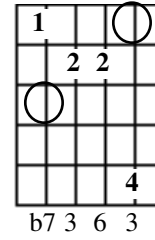

C 7/6 nr I

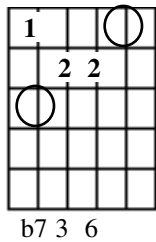

C 7/6 nr I

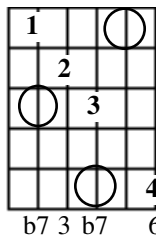

C 7/6 I

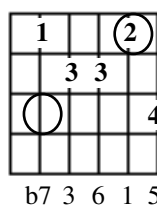

C 7/6 I

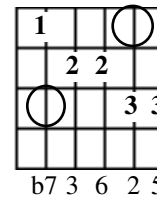

C 7/6 nr II

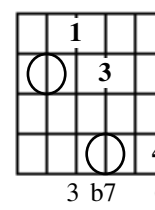

C 7/6 II

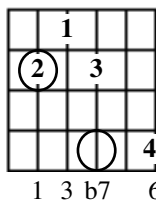

C 7/6 nr II

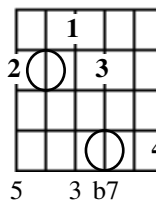

C 7/6 II

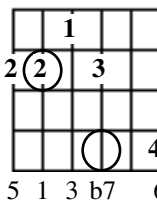

C 7/6 II

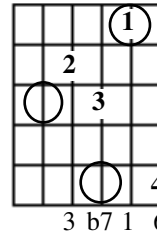

C 7/6 nr II

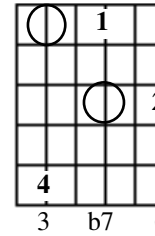

C 7/6 II

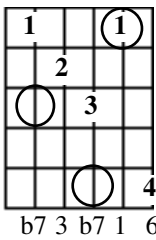

C 7/6 nr II

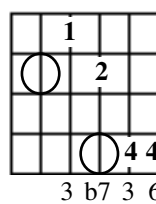

C 7/6 II

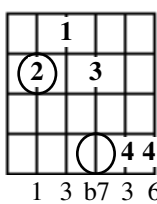

C 7/6 V

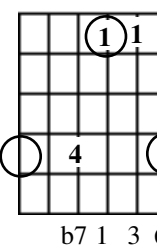

C 7/6 V

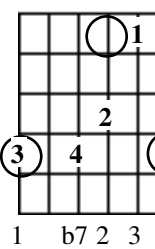

C 7/6 V

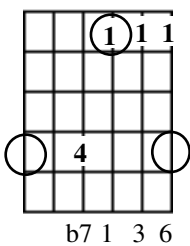

C 7/6 V

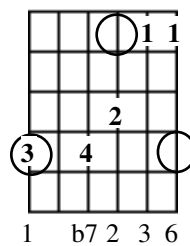

C 7/6 nr V

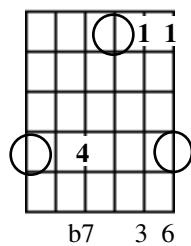

C 7/6 V

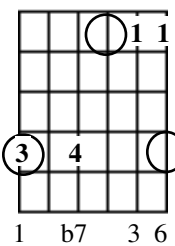

C 7/6 nr V

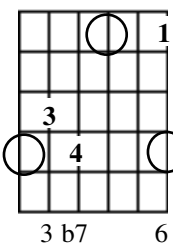

C 7/6 nr V

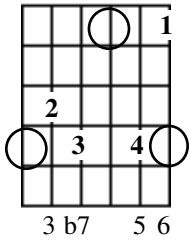

C 7/6 V

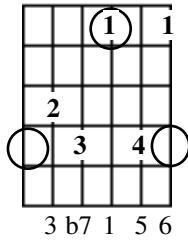

C 7/6 nr V

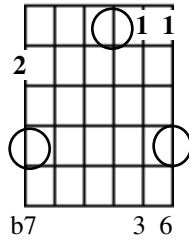

C 7/6 V

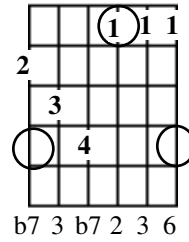

C 7/6 V

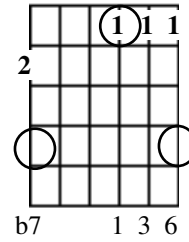

C 7/6 V

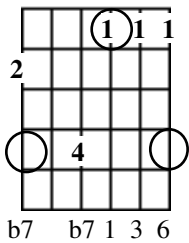

C 7/6 V

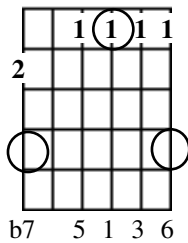

C 7/6 V

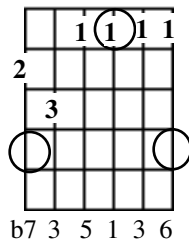

C 7/6 nr VII

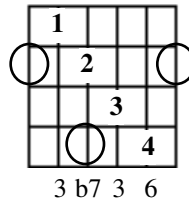

C 7/6 nr VII

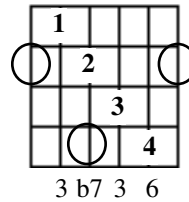

C 7/6 VII

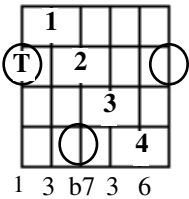

C 7/6 VIII

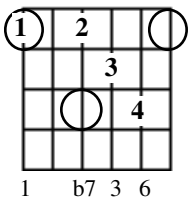

C 7/6 nr VIII

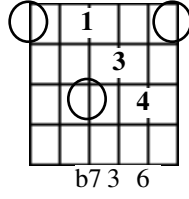

C 7/6 VIII

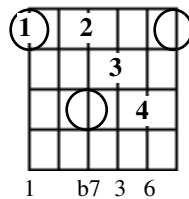

C 7/6 nr VIII

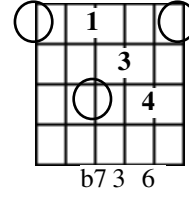

C 7/6 nr VIII

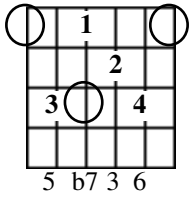

C 7/6 VIII

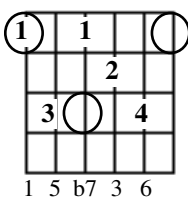

C 7/6 VIII

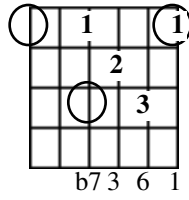

C 7/6 VIII

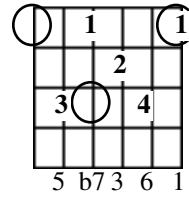

C 7/6 VIII

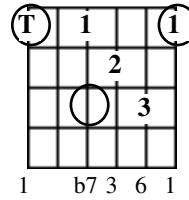

C 7/6 VIII

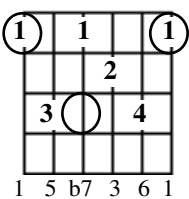

C 7/6 nr X

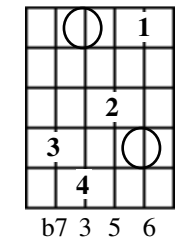

C 7/6 nr X

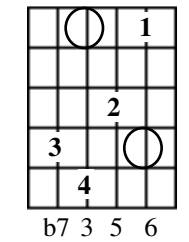

C 7/6 nr X

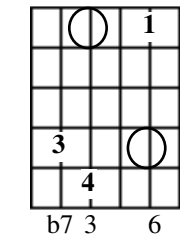

C 7/6 XII

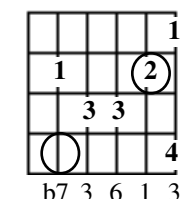

# dominant seventh add six suspended fourth

C 7/6sus4 nr III

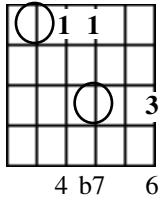

C 7/6sus4 nr III

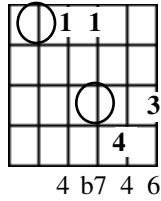

C 7/6sus4 III

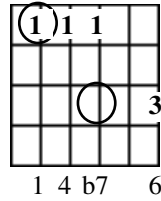

C 7/6sus4 III

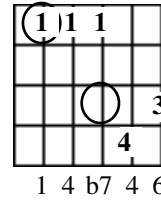

C 7/6sus4 III

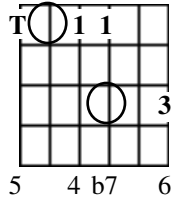

C 7/6sus4 III

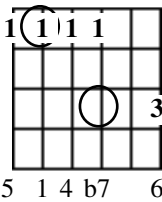

C 7/6sus4 III

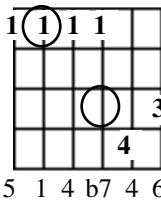

C 7/6sus4 nr III

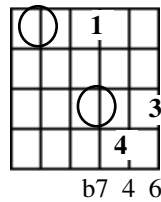

C 7/6sus4 III

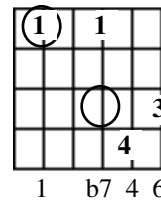

C 7/6sus4 nr III

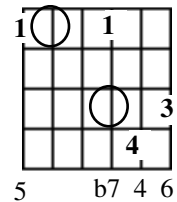

C 7/6sus4 nr V

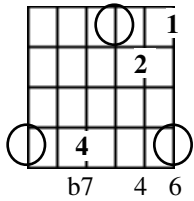

C 7/6sus4 V

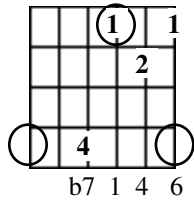

C 7/6sus4 V

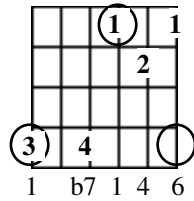

C 7/6sus4 V

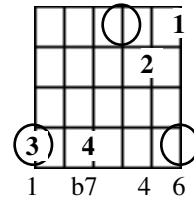

C 7/6sus4 nr VIII

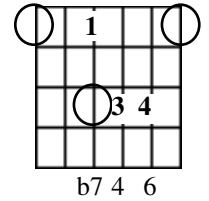

C 7/6sus4 VIII

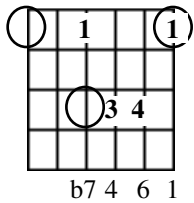

C 7/6sus4 nr VIII

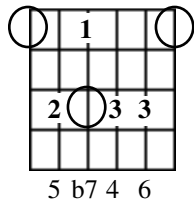

C 7/6sus4 VIII

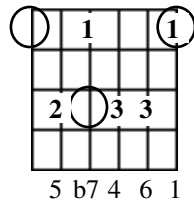

C 7/6sus4 VIII

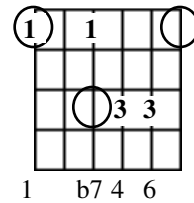

C 7/6sus4 VIII

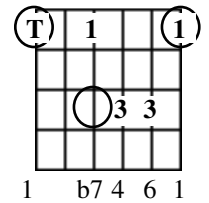

C 7/6sus4 VIII

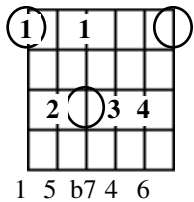

C 7/6sus4 VIII

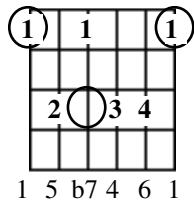

C 7/6sus4 nr X

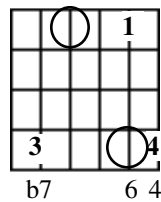

C 7/6sus4 nr X

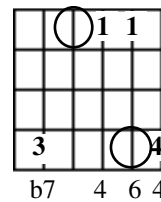

C 7/6sus4 nr X

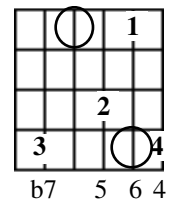

C 7/6sus4 X

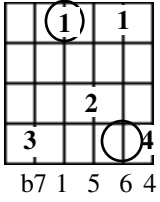

C 7/6sus4 nr X

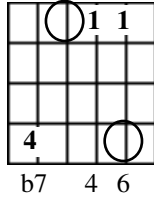

C 7/6sus4 X

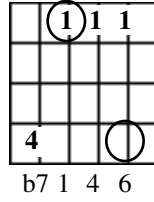

C 7/6sus4 X

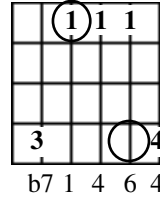

# dominant seventh add six flat nine

C 7/6b9 nr I

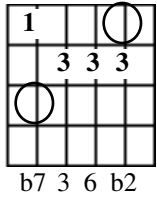

C 7/6b9 nr II

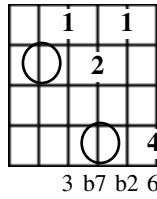

C 7/6b9 nr II

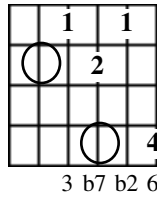

C 7/6b9 II

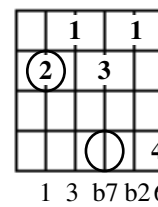

C 7/6b9 nr II

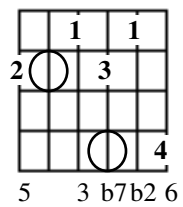

C 7/6b9 nr V

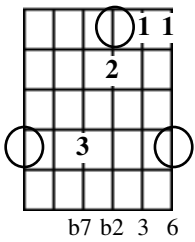

C 7/6b9 nr V

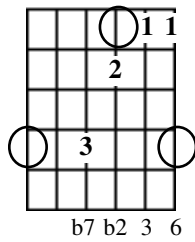

C 7/6b9 V

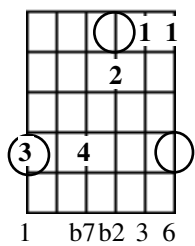

C 7/6b9 nr V

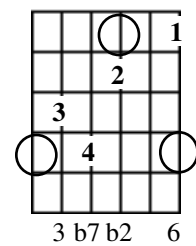

C 7/6b9 nr V

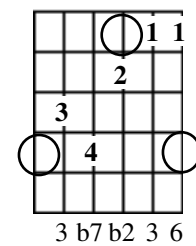

C 7/6b9 nr V

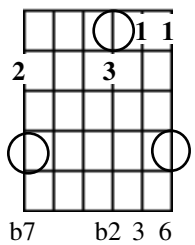

C 7/6b9 nr V

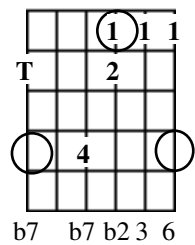

C 7/6b9 nr V

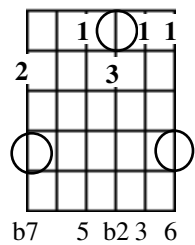

C 7/6b9 nr V

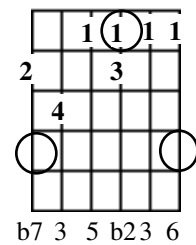

C 7/6b9 nr VI

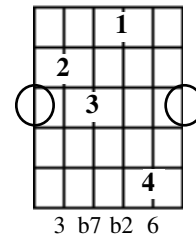

C 7/6b9 nr VI

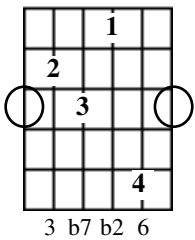

C 7/6b9 nr VII

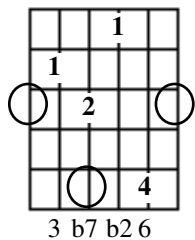

C 7/6b9 nr VIII

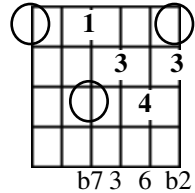

C 7/6b9 nr VIII

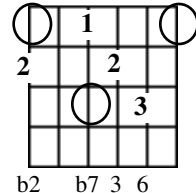

C 7/6b9 nr VIII

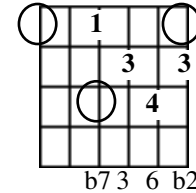

C 7/6b9 nr VIII

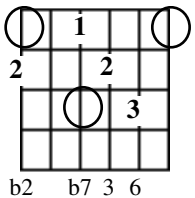

C 7/6b9 VIII

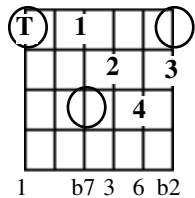



# dominant seventh add six add sharp eleven

C 7/6#11 nr I

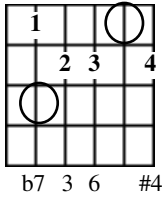

b7 3 6 #4

C 7/6#11 nr III

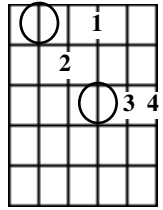

#4 b7 3 6

C 7/6#11 III

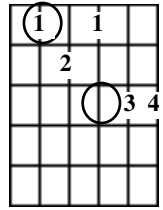

1 #4 b7 3 6

C 7/6#11 III

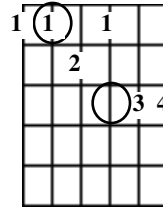

5 1 #4 b7 3 6

C 7/6#11 nr III

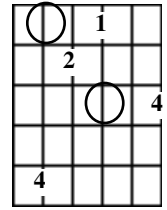

3 #4 b7 6

C 7/6#11 nr V

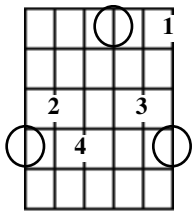

3 b7 #4 6

C 7/6#11 V

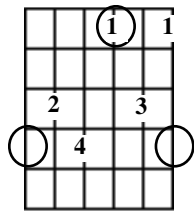

3 b7 1 #4 6

C 7/6#11 V

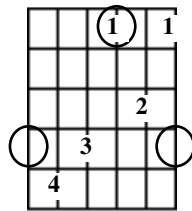

3 b7 1 #4 6

C 7/6#11 nr V

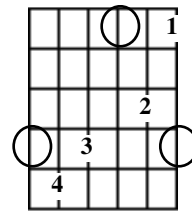

3 b7 #4 6

C 7/6#11 V

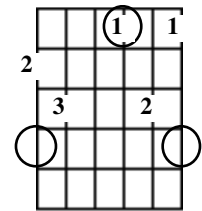

b7 3 1 #4 6

C 7/6#11 V

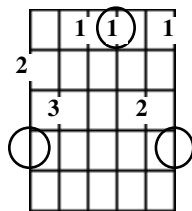

b7 3 5 1 #4 6

C 7/6#11 nr VIII

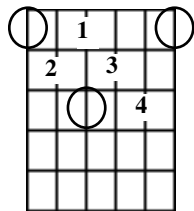

#4 b7 3 6

C 7/6#11 VIII

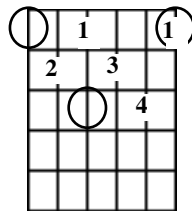

#4 b7 3 6 1

C 7/6#11 VIII

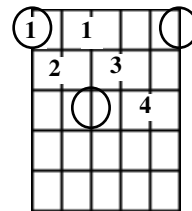

1 #4 b7 3 6

C 7/6#11 VIII

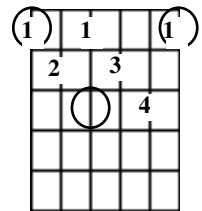

1 #4 b7 3 6

C 7/6#11 nr VIII

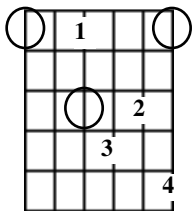

b7 #4 6 3

C 7/6#11 nr VIII

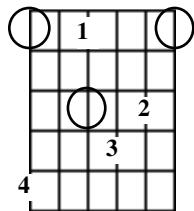

3 b7 #4 6

C 7/6#11 nr X

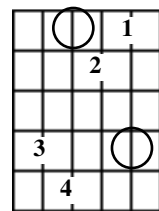

b7 3 #4 6

C 7/6#11 nr XII

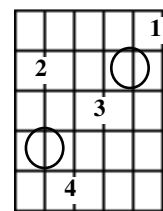

b7 #4 6 3

# dominant seventh add sharp eleven

C 7/#11 I

5 3 b7 1 #4

C 7/#11 I

3 b7 1 b5

C 7/#11 I

b5 3 b7 1

C 7/#11 I

b5 b7 1 3

C 7/#11 I

b5 b7 3 1

C 7/#11 I

b7 3 1 b5

C 7/#11 II

1 5 b7 3 #4

C 7/#11 II

1 b7 3 b5

C 7/#11 II

b5 1 3 b7

C 7/#11 II

1 3 b7 b5

C 7/#11 III

1 b5 b7 3

C 7/#11 III

1 b5 3 b7

C 7/#11 III

1 b5 1 3 b7

C 7/#11 IV

b7 b5 1 3

C 7/#11 V

3 5 1 #4 b7

C 7/#11 V

3 b7 1 b5

C 7/#11 V

3 1 b5 b7

C 7/#11 V

b7 3 1 b5

C 7/#11 V

b5 b7 1 3

C 7/#11 nr VI

1 b7 3 b5 b7

C 7/#11 VI

1 3 b5 b7

C 7/#11 VII

1 5 b7 3 #4

C 7/#11 VII

1 b7 3 b5

C 7/#11 VII

b7 3 b5 1

C 7/#11 VII

1 3 b7 b5

C 7/#11 VII

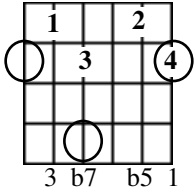

C 7/#11 VIII

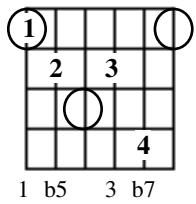

C 7/#11 VIII

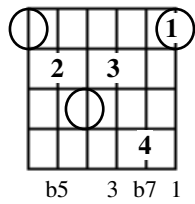

C 7/#11 VIII

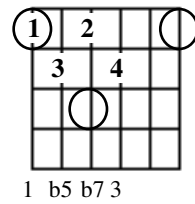

C 7/#11 VIII

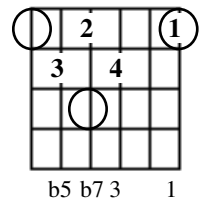

C 7/#11 IX

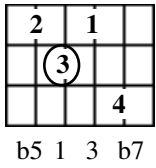

C 7/#11 IX

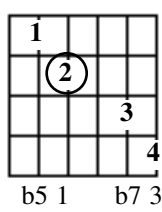

C 7/#11 IX

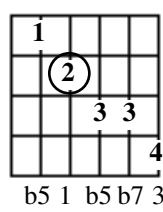

C 7/#11 X

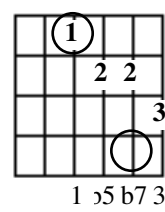

C 7/#11 X

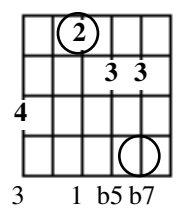

C 7/#11 XI

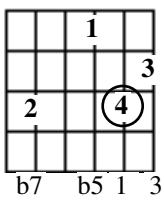

C 7/#11 XI

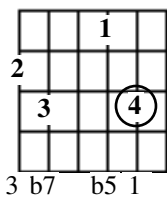

C 7/#11 XI

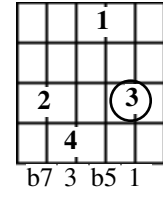

C 7/#11 XI

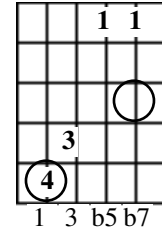

C 7/#11 XII

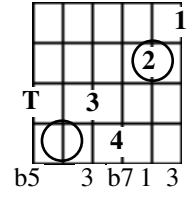

# dominant seventh suspended fourth

C 7sus4 I

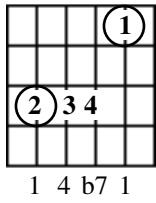

C 7sus4 I

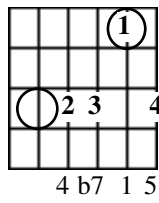

C 7sus4 I

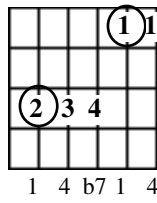

C 7sus4 I

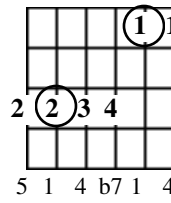

C 7sus4 I

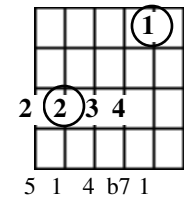

C 7sus4 III

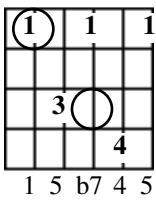

C 7sus4 III

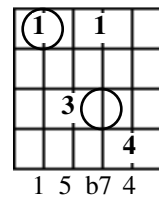

C 7sus4 III

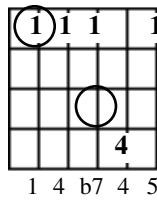

C 7sus4 III

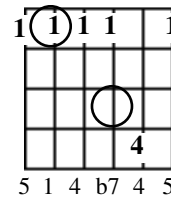

C 7sus4 V

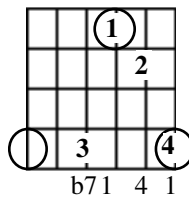

C 7sus4 V

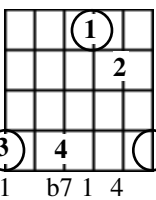

C 7sus4 V

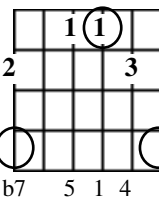

C 7sus4 V

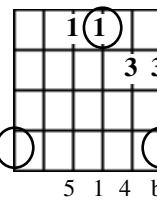

C 7sus4 V

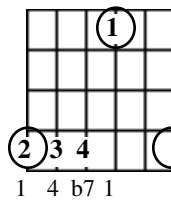

C 7sus4 VIII

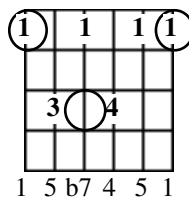

C 7sus4 VIII

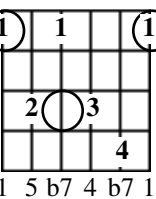

C 7sus4 VIII

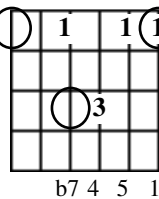

C 7sus4 VIII

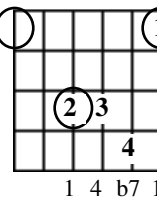

C 7sus4 VIII

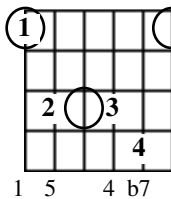

C 7sus4 VIII

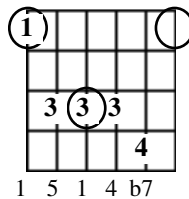

C 7sus4 VIII

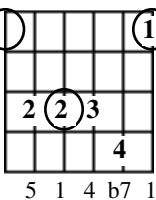

C 7sus4 VIII

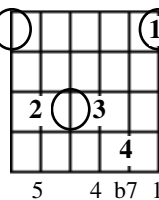

C 7sus4 X

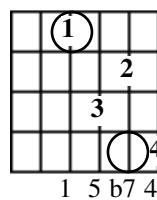

C 7sus4 X

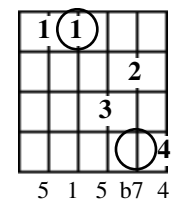

C 7sus4 X

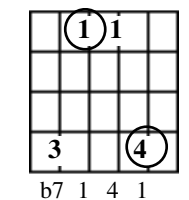

C 7sus4 XII

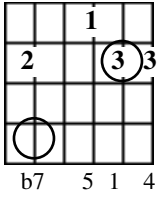

# dominant seventh suspended second

C 7sus2 nr III

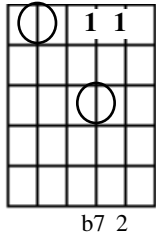

C 7sus2 nr III

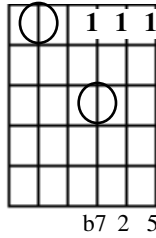

C 7sus2 nr III

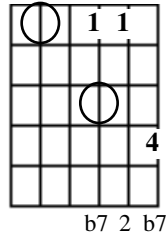

C 7sus2 nr III

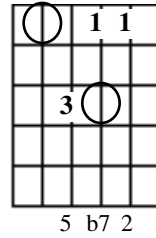

C 7sus2 nr III

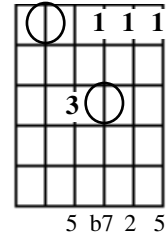

C 7sus2 nr III

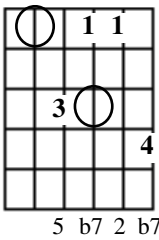

C 7sus2 III

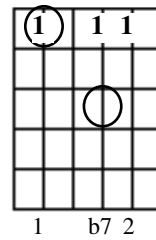

C 7sus2 III

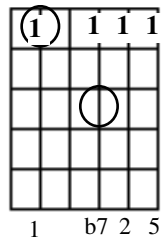

C 7sus2 III

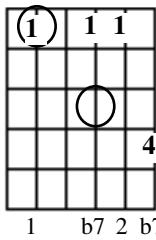

C 7sus2 III

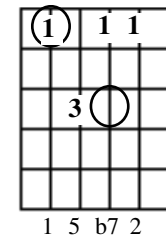

C 7sus2 III

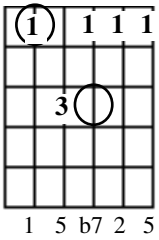

C 7sus2 III

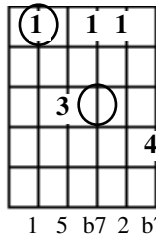

C 7sus2 nr III

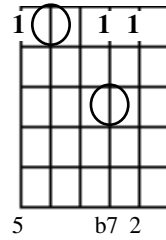

C 7sus2 nr III

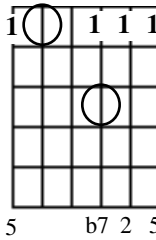

C 7sus2 nr III

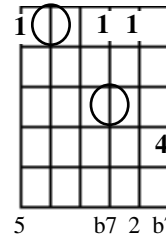

C 7sus2 nr III

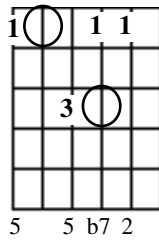

C 7sus2 nr III

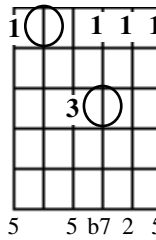

C 7sus2 nr III

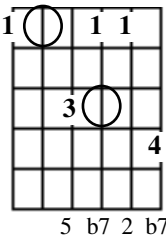

C 7sus2 III

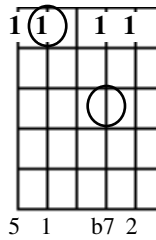

C 7sus2 III

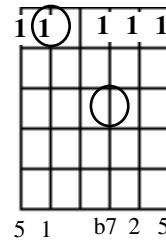

C 7sus2 III

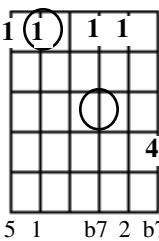

C 7sus2 III

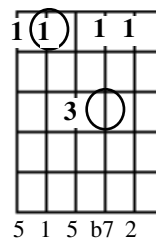

C 7sus2 III

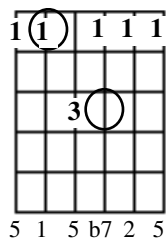

C 7sus2 III

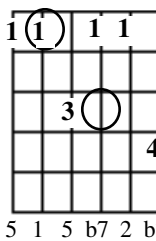

C 7sus2 nr III

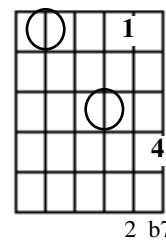

C 7sus2 III

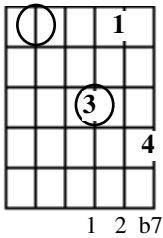

C 7sus2 nr III

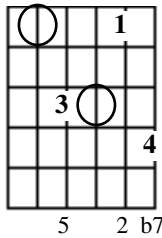

C 7sus2 III

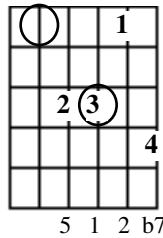

C 7sus2 III

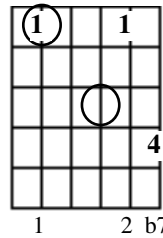

C 7sus2 III

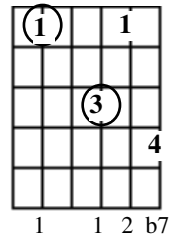

C 7sus2 III

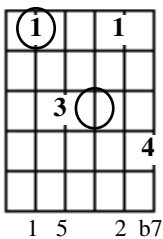

C 7sus2 III

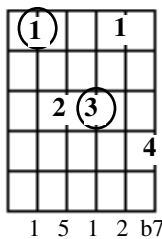

C 7sus2 nr III

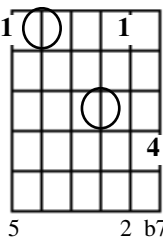

C 7sus2 III

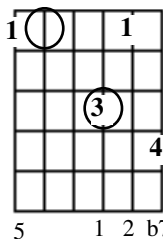

C 7sus2 nr III

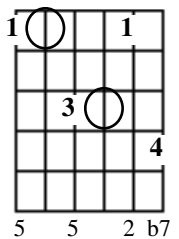

C 7sus2 III

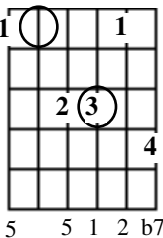

C 7sus2 III

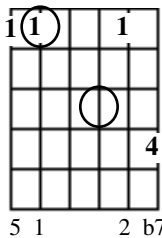

C 7sus2 III

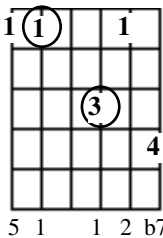

C 7sus2 III

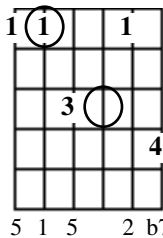

C 7sus2 III

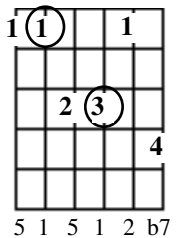

C 7sus2 nr V

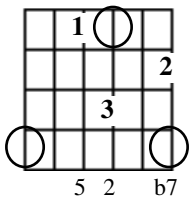

C 7sus2 nr V

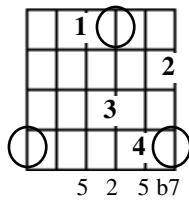

C 7sus2 V

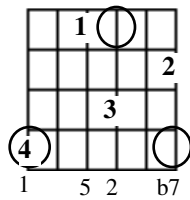

C 7sus2 nr VI

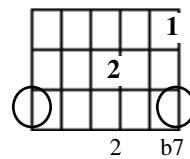

C 7sus2 VI

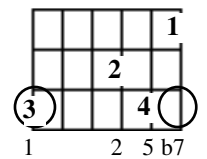

C 7sus2 VI

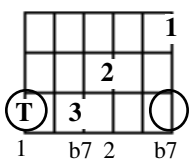

C 7sus2 VI

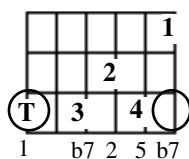

C 7sus2 nr VII

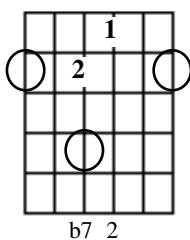

C 7sus2 nr VII

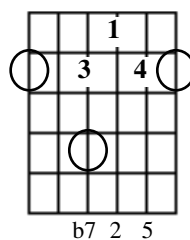

C 7sus2 VII

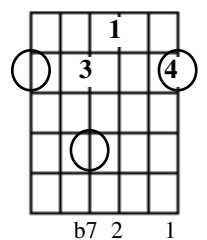

C 7sus2 VII

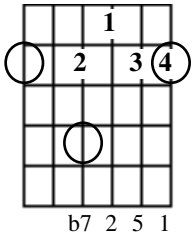

C 7sus2 nr VII

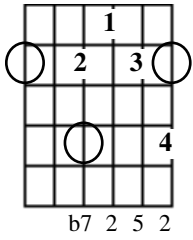

C 7sus2 nr VII

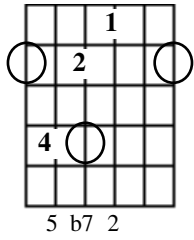

C 7sus2 nr VII

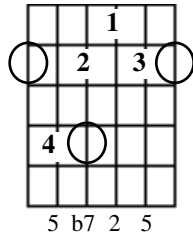

C 7sus2 VII

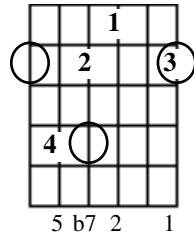

C 7sus2 nr VII

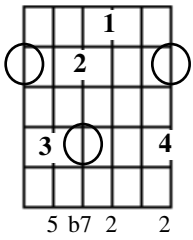

C 7sus2 VII

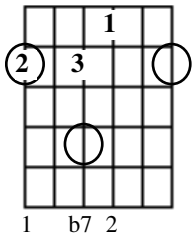

C 7sus2 VII

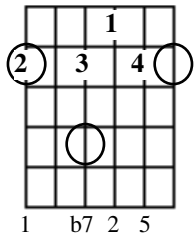

C 7sus2 VII

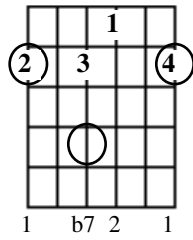

C 7sus2 VII

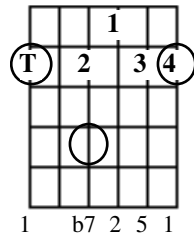

C 7sus2 VII

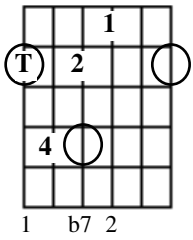

C 7sus2 VIII

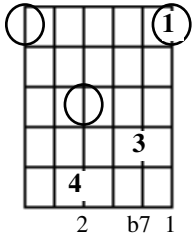

C 7sus2 VIII

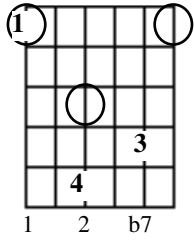

C 7sus2 VIII

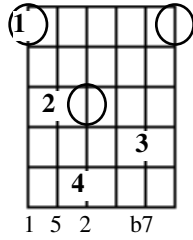

C 7sus2 VIII

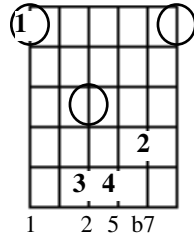

C 7sus2 VIII

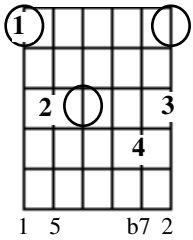

C 7sus2 VIII

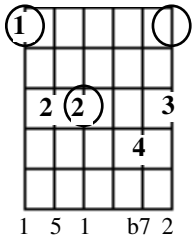

C 7sus2 VIII

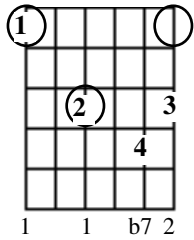

C 7sus2 nr X

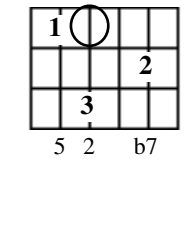

C 7sus2 nr X

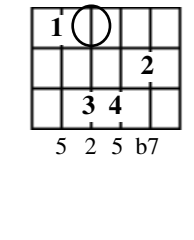

C 7sus2 nr X

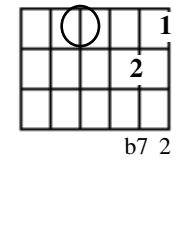

C 7sus2 nr X

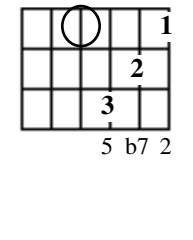

C 7sus2 X

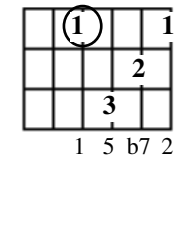

C 7sus2 X

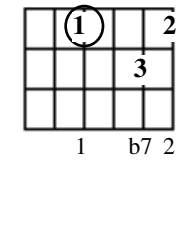

C 7sus2 nr X

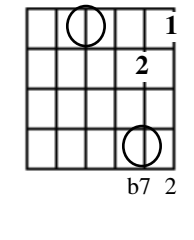



C 7sus2 nr X

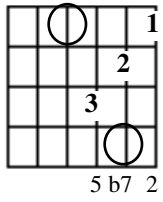

C 7sus2 X

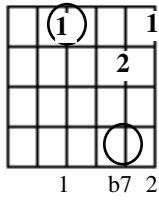

C 7sus2 X

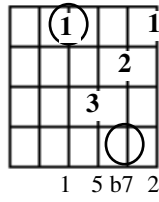

C 7sus2 X

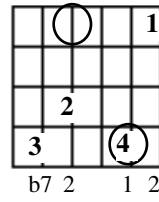

C 7sus2 nr X

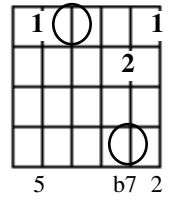

C 7sus2 nr X

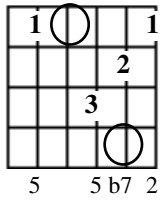

C 7sus2 X

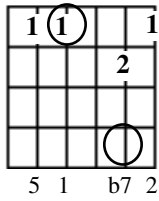

C 7sus2 X

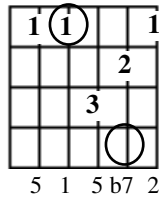

C 7sus2 X

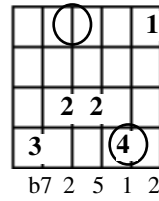

C 7sus2 nr XI

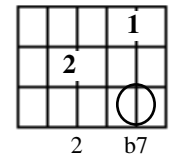

C 7sus2 nr XII

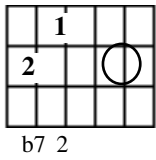

C 7sus2 nr XII

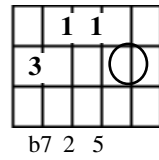

C 7sus2 XII

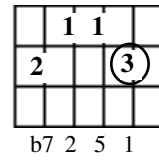

# dominant seventh flat nine

C 7b9 nr I

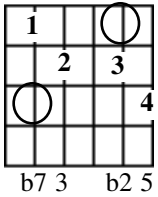

C 7b9 II

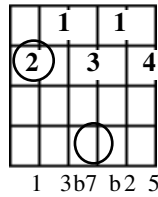

C 7b9 III

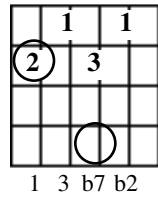

C 7b9 nr III

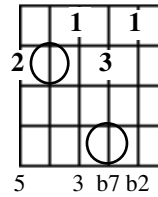

C 7b9 nr IV

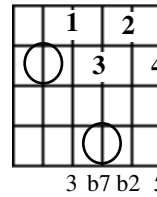

C 7b9 nr V

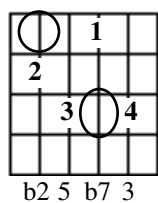

C 7b9 VI

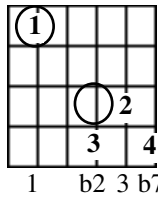

C 7b9 nr VI

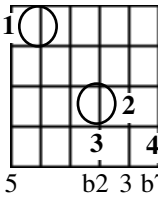

C 7b9 nr VII

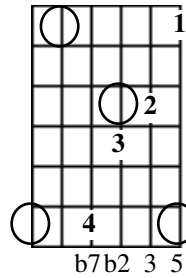

C 7b9 nr VIII

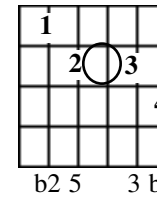

C 7b9 nr IX

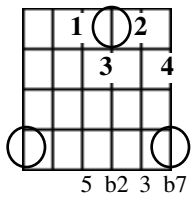

C 7b9 nr X

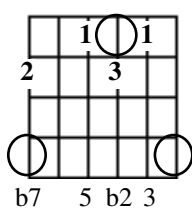

C 7b9 XI

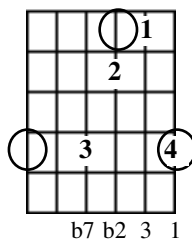

C 7b9 nr XII

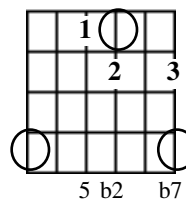

C 7b9 nr XIII

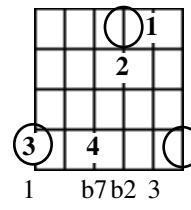

C 7b9 nr XIV

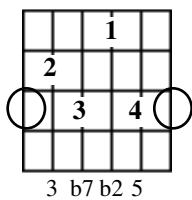

C 7b9 nr XV

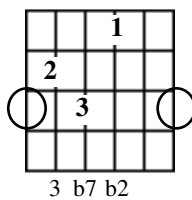

C 7b9 nr XVI

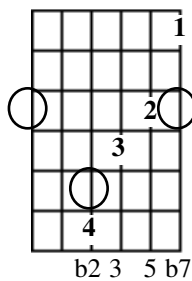

C 7b9 nr XVII

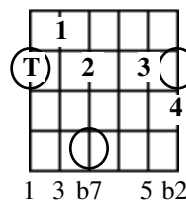

C 7b9 nr XVIII

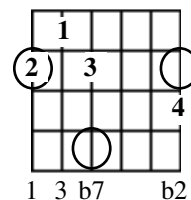

C 7b9 nr XIX

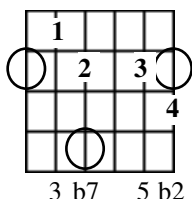

C 7b9 nr XX

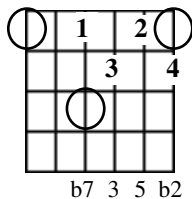

C 7b9 nr XXI

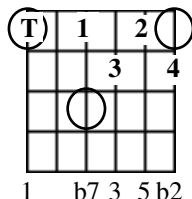

C 7b9 nr XXII

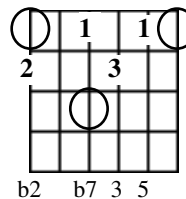

C 7b9 nr XXIII

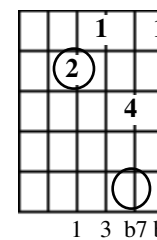

C 7b9 nr IX

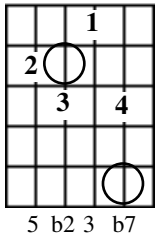

C 7b9 nr IX

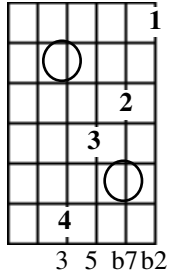

C 7b9 nr X

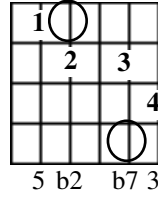

C 7b9 nr XI

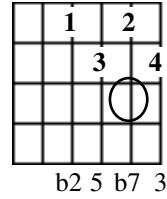

C 7b9 nr XI

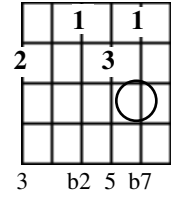

C 7b9 nr XII

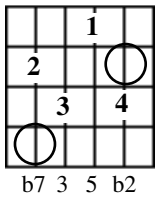

C 7b9 nr XII

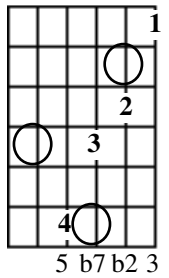

# dominant seventh flat nine suspended fourth

C 7b9sus4 I

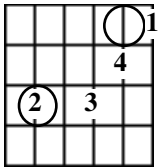

1 b7 b2 4

C 7b9sus4 II

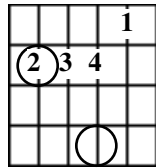

1 4 b7 b2

C 7b9sus4 III

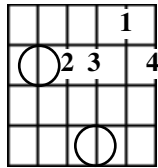

4 b7 b2 5

C 7b9sus4 IV

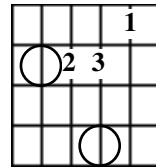

4 b7 b2

C 7b9sus4 V

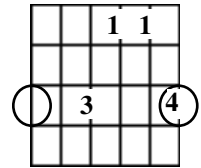

b7 b2 4 1

C 7b9sus4 VI

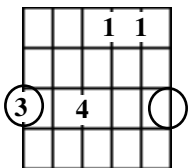

1 b7 b2 4

C 7b9sus4 VII

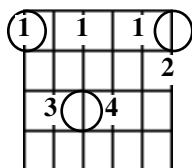

1 5 b7 4 5 b2

C 7b9sus4 VIII

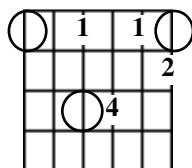

b7 4 5 b2

C 7b9sus4 IX

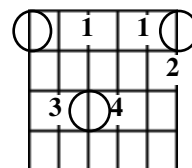

5 b7 4 5 b2

C 7b9sus4 X

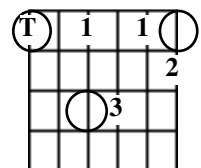

1 b7 4 5 b2

C 7b9sus4 XI

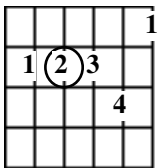

5 1 4 b7 b2

C 7b9sus4 XII

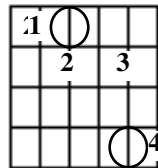

5 b2 b7 4

C 7b9sus4 XIII

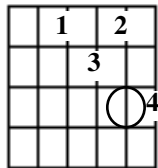

b2 5 b7 4

# dominant seventh flat nine sharp nine

C 7b9 nr I

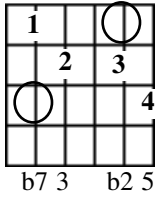

I

C 7b9 II

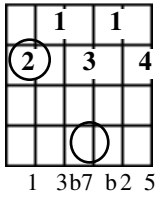

II

C 7b9 II

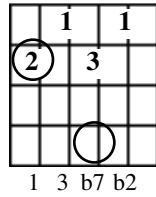

II

C 7b9 nr II

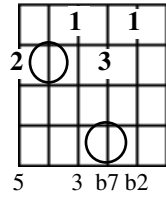

II

C 7b9 nr II

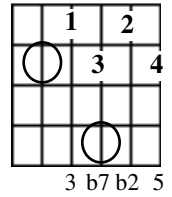

II

C 7b9 nr III

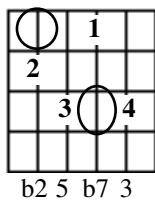

III

C 7b9 III

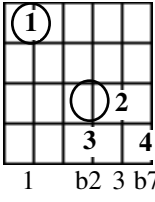

III

C 7b9 nr III

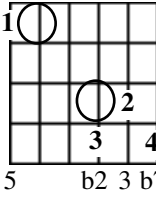

III

C 7b9 nr III

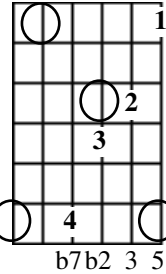

III

C 7b9 nr IV

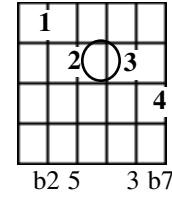

IV

C 7b9 nr V

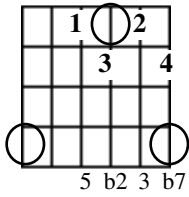

V

C 7b9 nr V

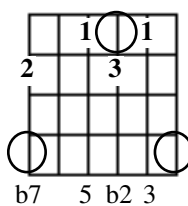

V

C 7b9 V

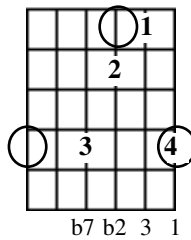

V

C 7b9 nr V

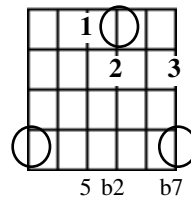

V

C 7b9 V

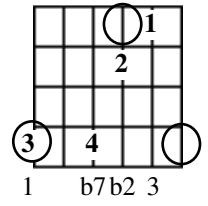

V

C 7b9 nr VI

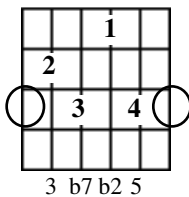

VI

C 7b9 nr VI

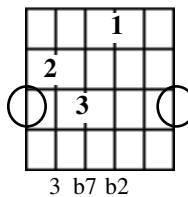

VI

C 7b9 nr VI

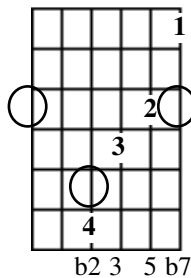

VI

C 7b9 VII

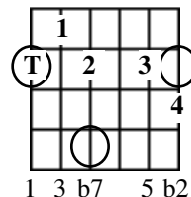

VII

C 7b9 VII

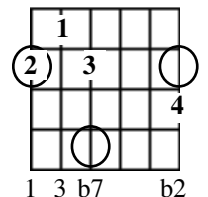

VII

C 7b9 nr VII

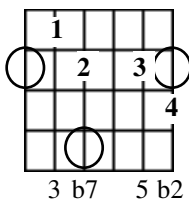

VII

C 7b9 nr VIII

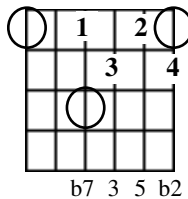

VIII

C 7b9 VIII

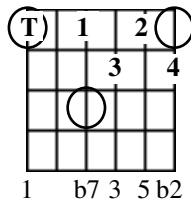

VIII

C 7b9 nr VIII

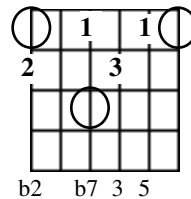

VIII

C 7b9 IX

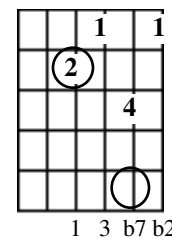

IX

C 7b9 nr IX

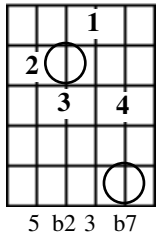

C 7b9 nr IX

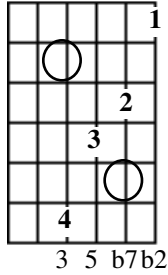

C 7b9 nr X

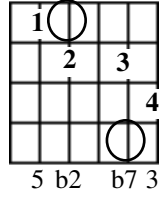

C 7b9 nr XI

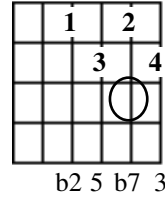

C 7b9 nr XI

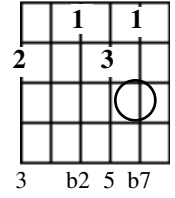

C 7b9 nr XII

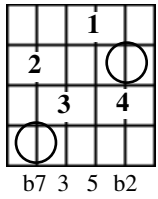

C 7b9 nr XII

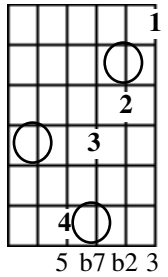

# dominant seventh flat nine sharp eleven

C 7b9#11 II

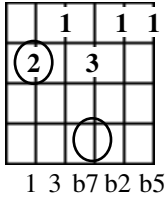

C 7b9#11 nr II

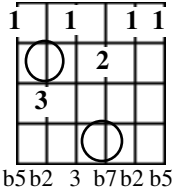

C 7b9#11 nr II

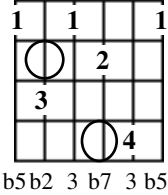

C 7b9#11 nr II

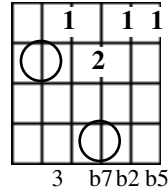

C 7b9#11 nr II

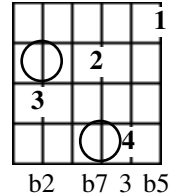

C 7b9#11 nr II

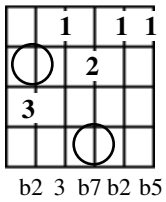

C 7b9#11 nr II

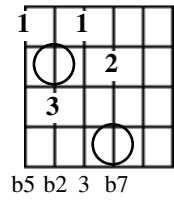

C 7b9#11 nr III

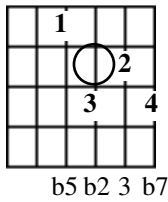

C 7b9#11 nr III

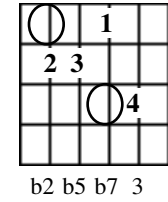

C 7b9#11 nr IV

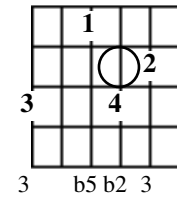

C 7b9#11 V

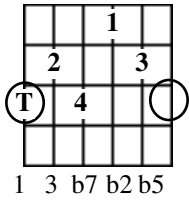

C 7b9#11 nr V

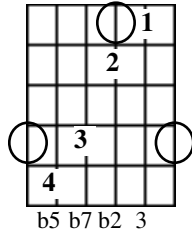

C 7b9#11 nr VI

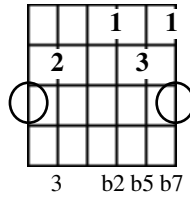

C 7b9#11 VII

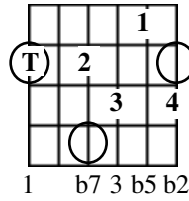

C 7b9#11 nr VII

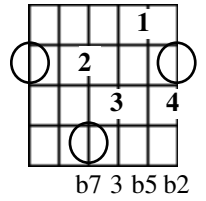

C 7b9#11 nr VIII

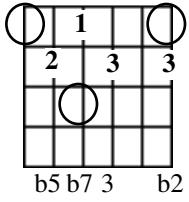

C 7b9#11 VIII

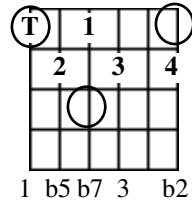

C 7b9#11 nr VIII

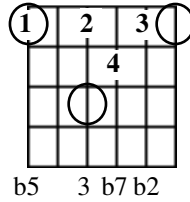

C 7b9#11 IX

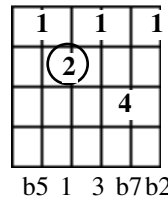

C 7b9#11 nr IX

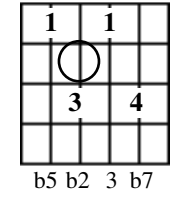

C 7b9#11 nr IX

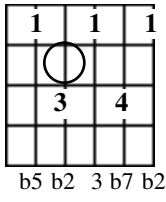

C 7b9#11 nr IX

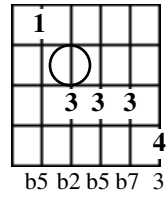

C 7b9#11 nr IX

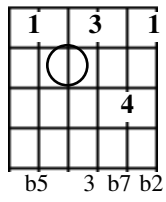

C 7b9#11 nr X

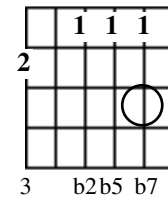

C 7b9#11 nr XI

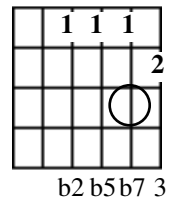

C 7b9#11 nr XI

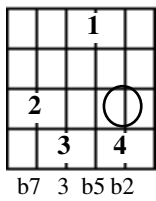

C 7b9#11 nr XI

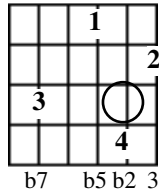

C 7b9#11 nr XI

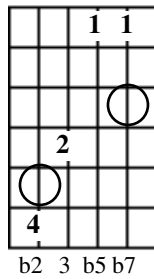

C 7b9#11 nr XII

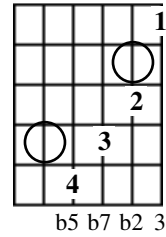

C 7b9#11 nr XII

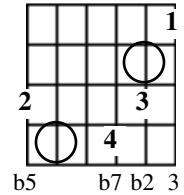

## dominant seventh sharp nine

C 7#9 nr I

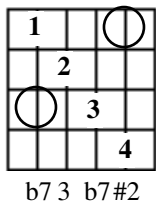

C 7#9 II

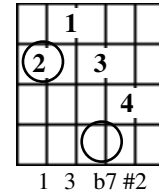

C 7#9 nr II

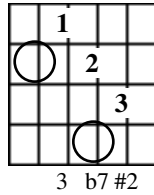

C 7#9 nr II

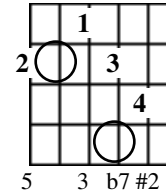

C 7#9 nr II

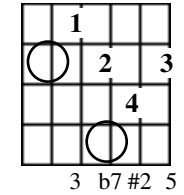

C 7#9 nr III

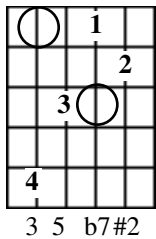

C 7#9 nr III

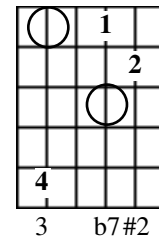

C 7#9 IV

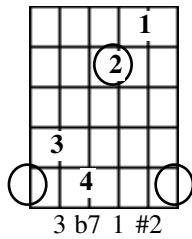

C 7#9 VII

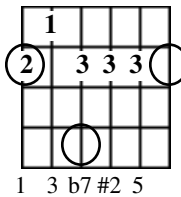

C 7#9 VII

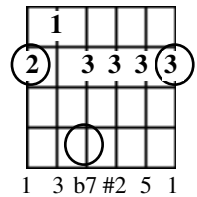

C 7#9 VII

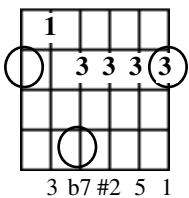

C 7#9 nr VII

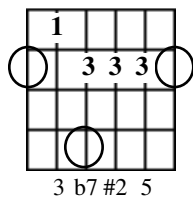

C 7#9 nr VII

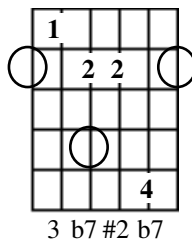

C 7#9 nr VII

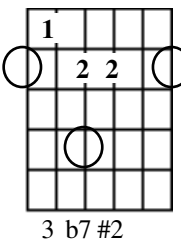

C 7#9 VIII

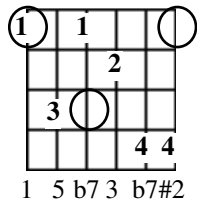

C 7#9 VIII

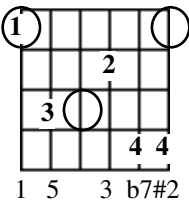

C 7#9 IX

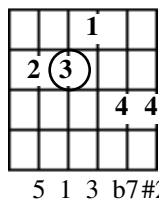

C 7#9 IX

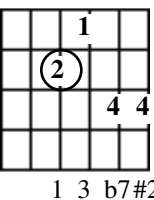

C 7#9 nr IX

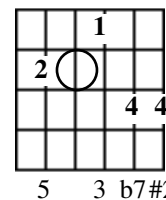

C 7#9 nr XI

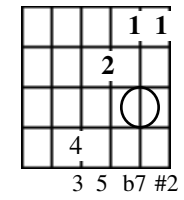



# dominant seventh sharp nine sharp eleven

C 7#9#11 II

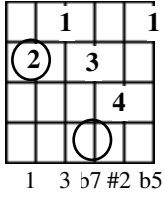

C 7#9#11 nr II

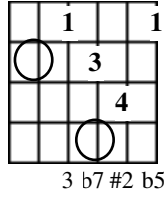

C 7#9#11 nr III

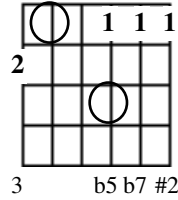

C 7#9#11 nr VI

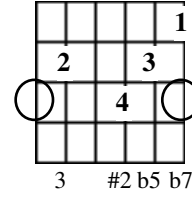

C 7#9#11 VII

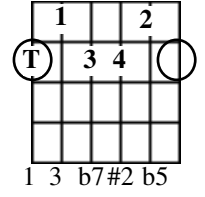

C 7#9#11 nr VII

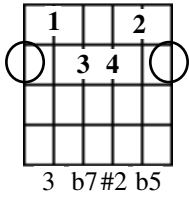

C 7#9#11 VIII

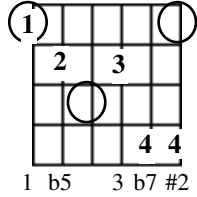

C 7#9#11 IX

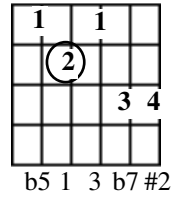

C 7#9#11 nr IX

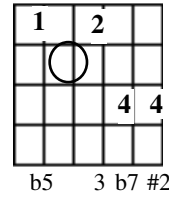

C 7#9#11 XI

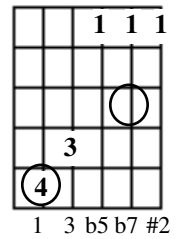

C 7#9#11 XI

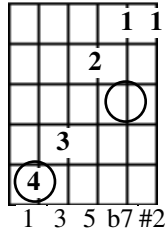

C 7#9#11 nr XI

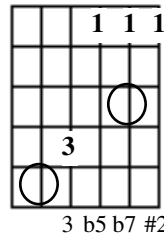

# dominant seventh sharp nine sharp eleven

C 7#9#11 II

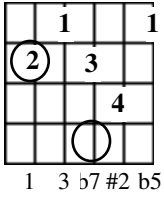

C 7#9#11 nr II

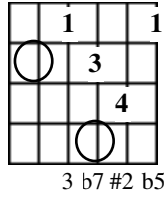

C 7#9#11 nr III

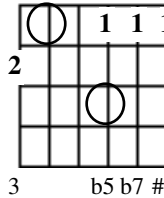

C 7#9#11 nr VI

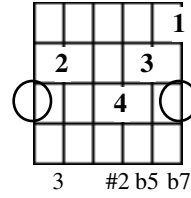

C 7#9#11 VII

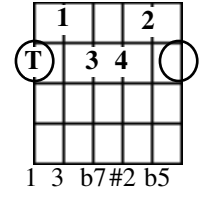

C 7#9#11 nr VII

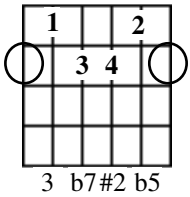

C 7#9#11 VIII

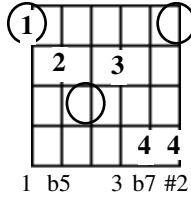

C 7#9#11 IX

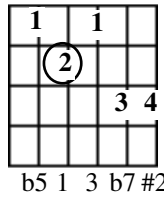

C 7#9#11 nr IX

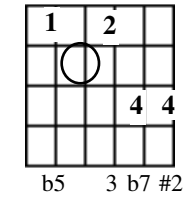

C 7#9#11 XI

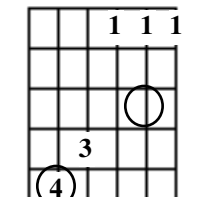

C 7#9#11 XI

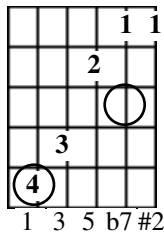

C 7#9#11 nr XI

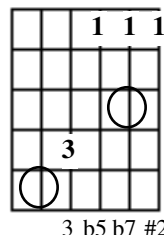

# dominant seventh flat five

C 7b5 I

3 b7 1 b5

C 7b5 I

b5 3 b7 1

C 7b5 I

b5 b7 1 3

C 7b5 I

b5 b7 3 1

C 7b5 I

b7 3 1 b5

C 7b5 II

1 b7 3 b5

C 7b5 II

b5 1 3 b7

C 7b5 II

1 3 b7 b5

C 7b5 III

1 b5 b7 3

C 7b5 III

1 b5 3 b7

C 7b5 III

1 b5 1 3 b7

C 7b5 IV

b7 b5 1 3

C 7b5 V

3 b7 1 b5

C 7b5 V

3 1 b5 b7

C 7b5 V

b7 3 1 b5

C 7b5 V

b5 b7 1 3

C 7b5 nr VI

1 b7 3 b5b7

C 7b5 VI

1 3 b5 b7

C 7b5 VII

1 b7 3 b5

C 7b5 VII

b7 3 b5 1

C 7b5 VII

1 3 b7 b5

C 7b5 VII

3 b7 b5 1

C 7b5 VIII

1 b5 3 b7

C 7b5 VIII

b5 3 b7 1

C 7b5 VIII

1 b5 b7 3

C 7b5 VIII

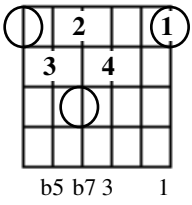

C 7b5 IX

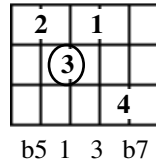

C 7b5 IX

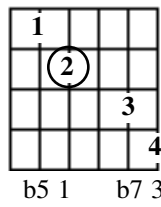

C 7b5 IX

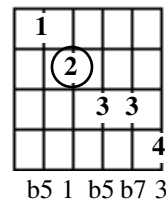

C 7b5 X

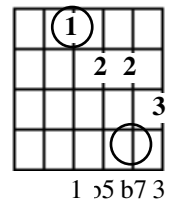

C 7b5 X

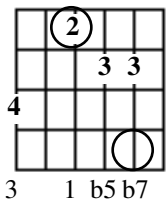

C 7b5 XI

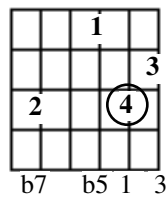

C 7b5 XI

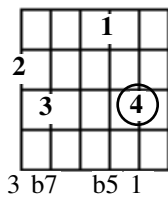

C 7b5 XI

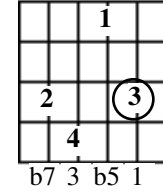

C 7b5 XI

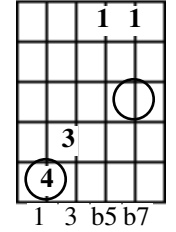

C 7b5 XII

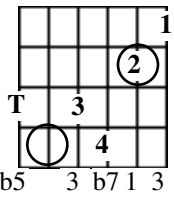

# dominant seventh add six flat five

C 7/6b5

I

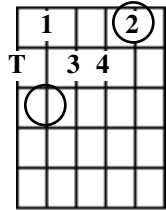

b5 b7 3 6 1

C 7/6b5 nr

III

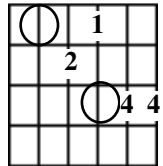

b5 b7 3 6

C 7/6b5

III

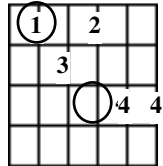

1 b5 b7 3 6

C 7/6b5

III

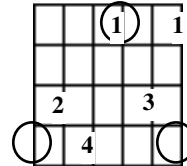

3 b7 1 b5 6

C 7/6b5 nr

V

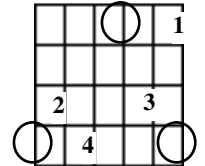

3 b7 b5 6

C 7/6b5

VIII

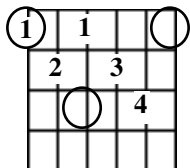

1 b5 b7 3 6

C 7/6b5 nr

VIII

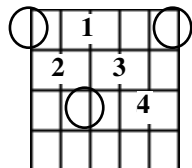

b5 b7 3 6

C 7/6b5

VIII

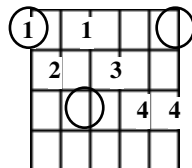

1 b5 b7 3 6 2

C 7/6b5

VIII

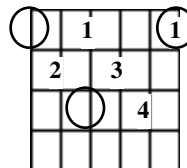

b5 b7 3 6 1

C 7/6b5 nr

X

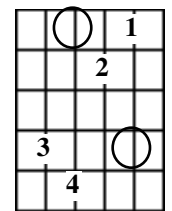

b7 3 b5 6

C 7/6b5

X

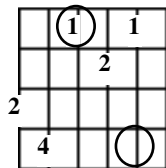

3 b7 1 b5 6

# dominant seventh add six flat five flat nine

C 7/6b5b9 nr I

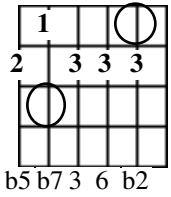

C 7/6b5b9 II

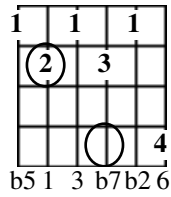

C 7/6b5b9 nr V

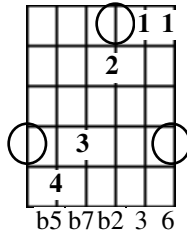

C 7/6b5b9 nr V

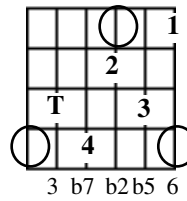

C 7/6b5b9 nr V

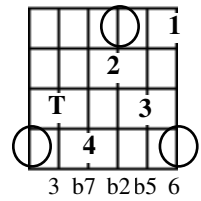

C 7/6b5b9 nr V

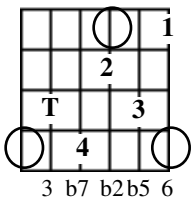

C 7/6b5b9 nr V

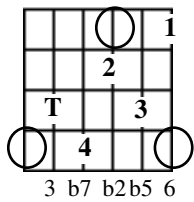

C 7/6b5b9 nr V

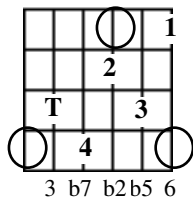

C 7/6b5b9 nr V

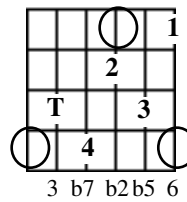

C 7/6b5b9 nr V

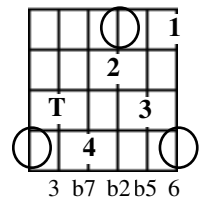

C 7/6b5b9 nr V

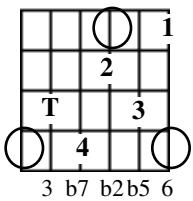

C 7/6b5b9 nr V

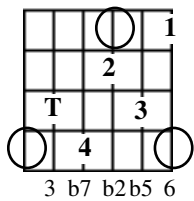

C 7/6b5b9 nr V

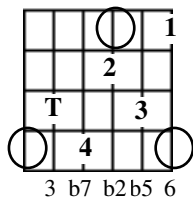

C 7/6b5b9 nr V

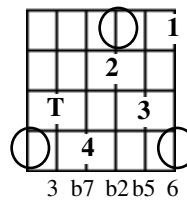

C 7/6b5b9 nr V

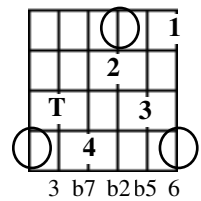

C 7/6b5b9 nr V

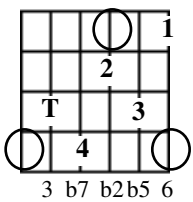

C 7/6b5b9 nr V

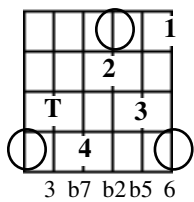

C 7/6b5b9 nr V

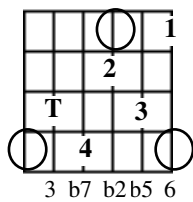

C 7/6b5b9 nr V

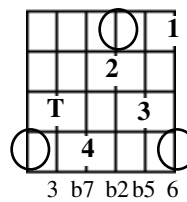

C 7/6b5b9 nr V

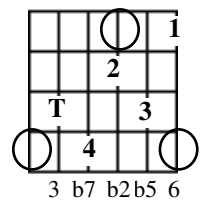

C 7/6b5b9 nr V

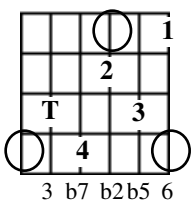

C 7/6b5b9 nr V

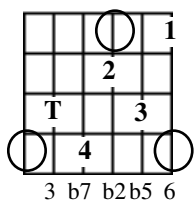

C 7/6b5b9 nr V

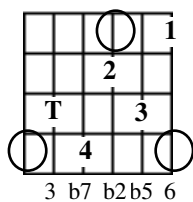

C 7/6b5b9 nr V

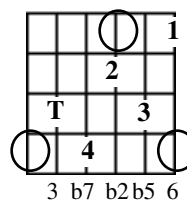

C 7/6b5b9 nr VIII

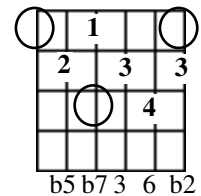

# dominant seventh flat five sharp five

C 7b5#5

I

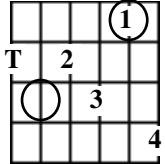

b5 3 b7 1 #5

C 7b5#5

II

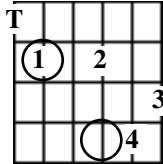

b5 1 b7 3 #5

C 7b5#5

II

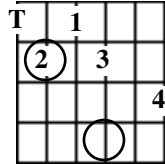

b5 1 3 b7 #5

C 7b5#5

III

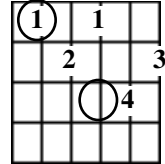

1 b5b7 3 #5

C 7b5#5 nr

III

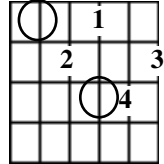

b5 b7 3 #5

C 7b5#5

IV

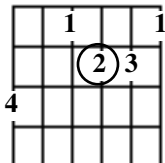

b7 b5 1 3 #5

C 7b5#5

VIII

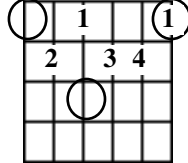

b5 b7 3 #5 1

C 7b5#5

VIII

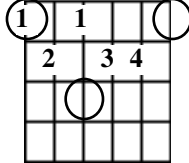

1 b5 b7 3 #5

C 7b5#5

VIII

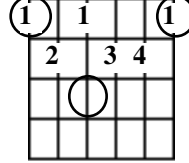

1 b5 b7 3 #5 1

C 7b5#5 nr

VIII

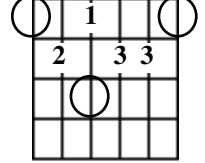

b5 b7 3 #5

C 7b5#5 nr

XI

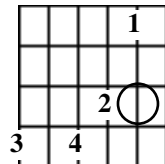

b5 3#5 b7

# dominant seventh flat five flat nine

C 7b5b9 II

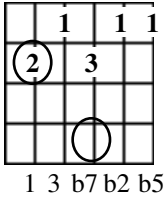

C 7b5b9 nr II

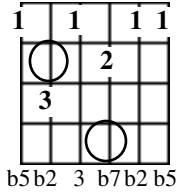

C 7b5b9 nr II

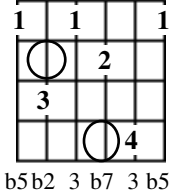

C 7b5b9 nr II

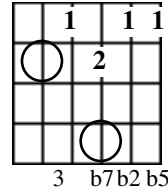

C 7b5b9 nr II

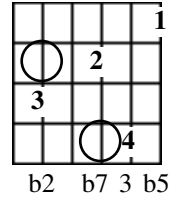

C 7b5b9 nr II

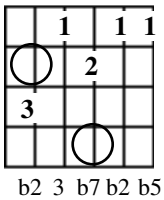

C 7b5b9 nr II

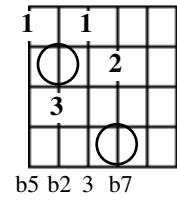

C 7b5b9 nr III

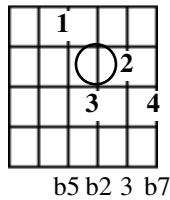

C 7b5b9 nr III

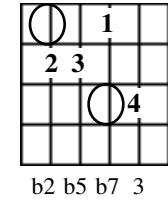

C 7b5b9 nr IV

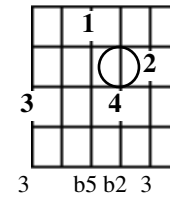

C 7b5b9 V

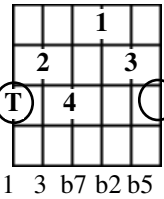

C 7b5b9 nr V

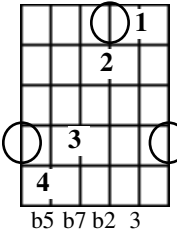

C 7b5b9 nr VI

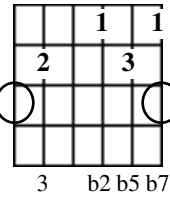

C 7b5b9 VII

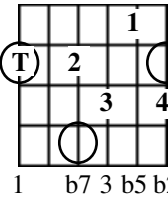

C 7b5b9 nr VII

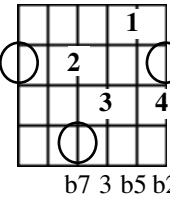

C 7b5b9 nr VIII

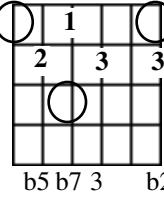

C 7b5b9 VIII

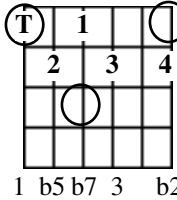

C 7b5b9 nr VIII

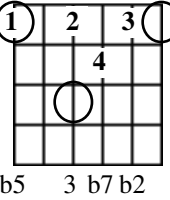

C 7b5b9 IX

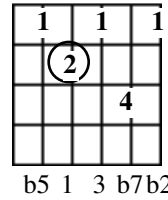

C 7b5b9 nr IX

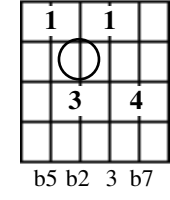

C 7b5b9 nr IX

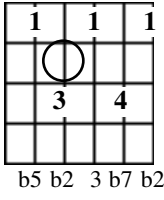

C 7b5b9 nr IX

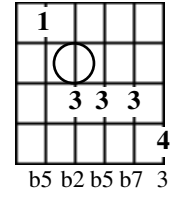

C 7b5b9 nr IX

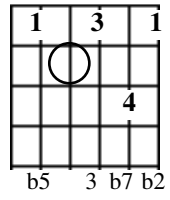

C 7b5b9 nr X

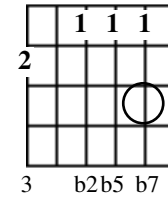

C 7b5b9 nr XI

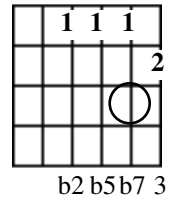



C 7b5b9 nr XI

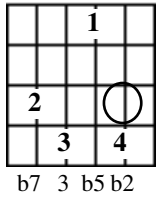

C 7b5b9 nr XI

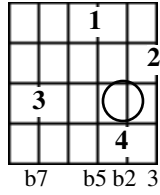

C 7b5b9 nr XI

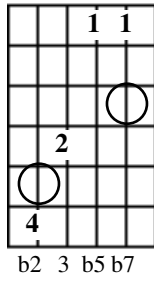

C 7b5b9 nr XII

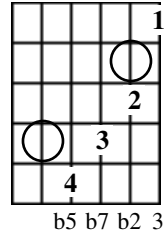

C 7b5b9 nr XII

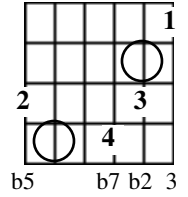

# dominant seventh flat five flat nine sharp nine

C 7b5b9#9 II

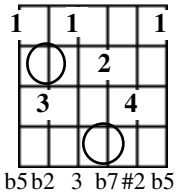

b5 b2 3 b7 #2 b5

C 7b5b9#9 II

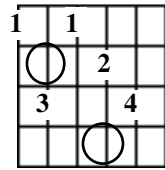

b5 b2 3 b7 #2

C 7b5b9#9 IX

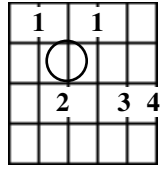

b5 b2 3 b7 #2

C 7b5b9#9 XI

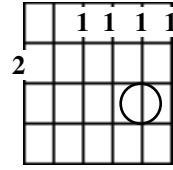

3 b2 b5 b7 #2

C 7b5b9#9 XI

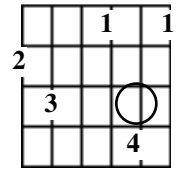

3 b7 b5 b2 #2

C 7b5b9#9 XI

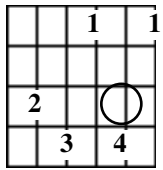

b7 3 b5 b2 #2

C 7b5b9#9 XI

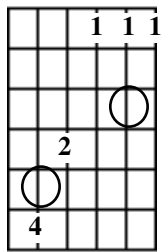

b2 3 b5 b7 #2

C 7b5b9#9 XI

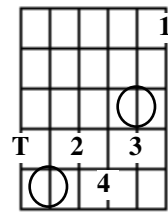

b5 3 b7 b2 #2

# dominant seventh flat five sharp nine

C 7b5#9 II

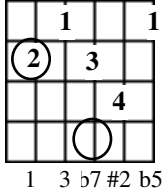

C 7b5#9 nr II

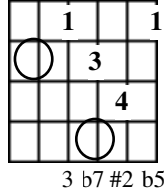

C 7b5#9 nr III

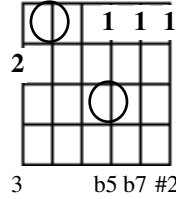

C 7b5#9 nr VI

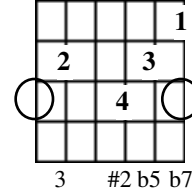

C 7b5#9 VII

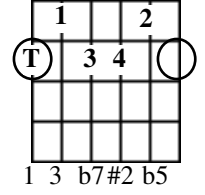

C 7b5#9 nr VII

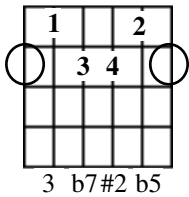

C 7b5#9 VIII

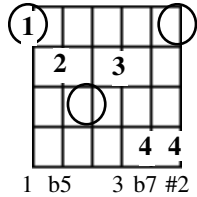

C 7b5#9 IX

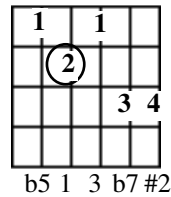

C 7b5#9 nr IX

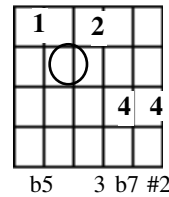

C 7b5#9 XI

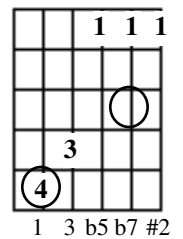

C 7b5#9 XI

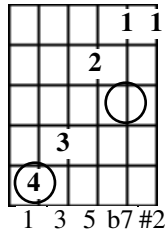

C 7b5#9 nr XI

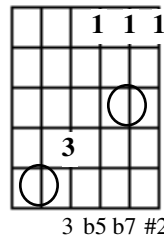

# dominant seventh flat five sharp five flat nine

C 7b5#5b9 II

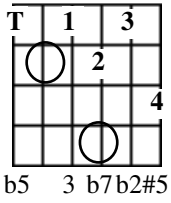

C 7b5#5b9 II

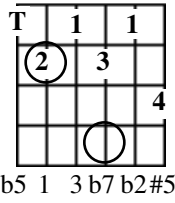

C 7b5#5b9 IV

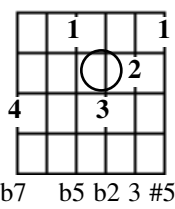

C 7b5#5b9 VIII

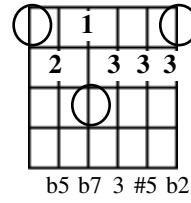

C 7b5#5b9 VIII

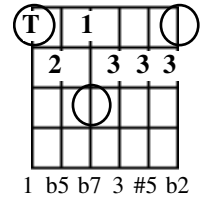

# dominant seventh flat five sharp five sharp nine

C 7b5#5#9 II

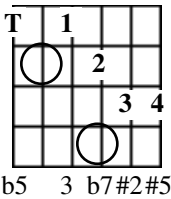

C 7b5#5#9 II

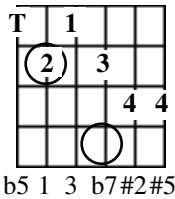

C 7b5#5#9 VIII

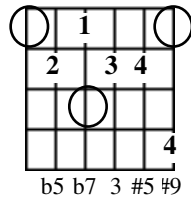

C 7b5#5#9 VIII

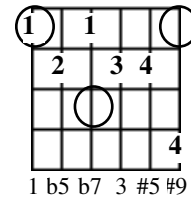

C 7b5#5#9 XI

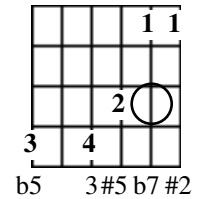

# dominant seventh sharp five

C 7#5 I	C 7#5 I	C 7#5 I	C 7#5 I	C 7#5 II
b7 3 #5 1	3 b7 1 #5	#5 3 b7 1	b7 3 1 #5	1 3 b7 #5
C 7#5 III	C 7#5 III	C 7#5 III	C 7#5 III	C 7#5 IV
1 b7 3 #5	1 #5 b7 3	1 3 b7 #5	1 #5 3 b7	#5 1 3 b7
C 7#5 V	C 7#5 V	C 7#5 V	C 7#5 VI	C 7#5 VII
#5 1 3 b7	b7 #5 1 3	3 b7 1 #5	1 3 #5 b7	1 3 b7 #5
C 7#5 VII	C 7#5 VIII	C 7#5 VIII	C 7#5 nr VIII	C 7#5 VIII
3 b7 #5 1	1 b7 3 #5	b7 3 #5 1	b7 3 #5	#5 3 b7 1
C 7#5 VIII	C 7#5 IX	C 7#5 IX	C 7#5 X	C 7#5 X
1 #5 3 b7	b7 1 3 #5	#5 1 3 b7	1 #5 b7 3	#5 1 b7 3

C 7#5 X

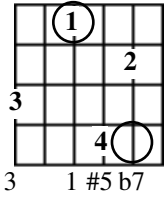

C 7#5 XI

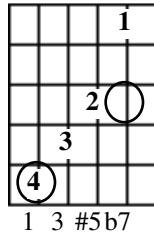

C 7#5 XII

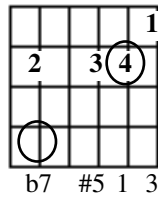

C 7#5 XII

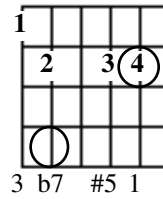

## dominant seventh sharp five flat nine

C 7#5b9 nr I

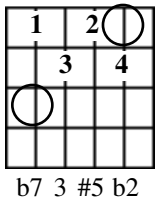

C 7#5b9 II

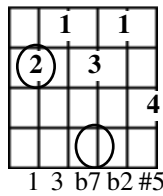

C 7#5b9 nr II

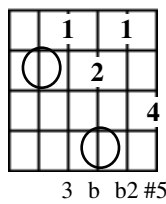

C 7#5b9 nr VI

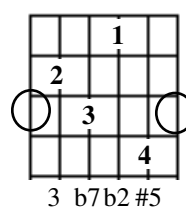

C 7#5b9 VI

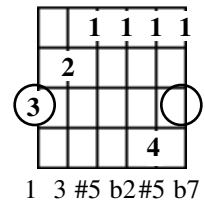

C 7#5b9 VIII

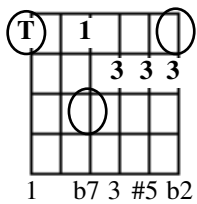

C 7#5b9 IX

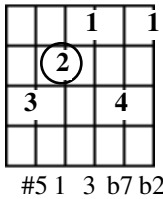

C 7#5b9 nr XII

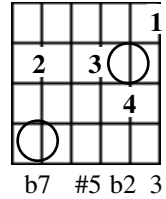

## dominant seventh sharp five flat nine sharp nine

C 7#5b9#9 IV

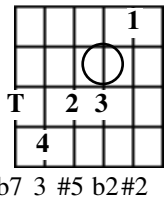

C 7#5b9#9 XI

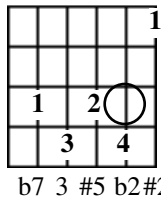

# dominant seventh sharp five sharp nine

C 7#5#9 nr I

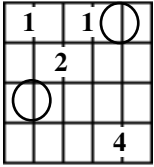

b7 3 #5#2

C 7#5#9 nr I

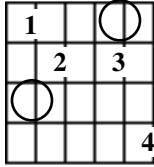

b7 3 b2#5

C 7#5#9 nr I

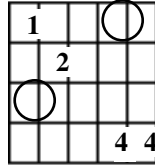

b7 3 #2#5

C 7#5#9 II

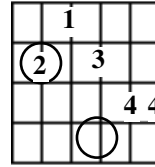

1 3 b7#5 #2

C 7#5#9 II

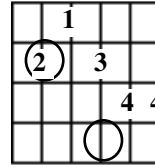

1 3 b7#2#5

C 7#5#9 nr II

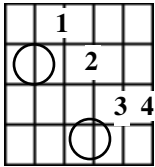

3 b7#5 #2

C 7#5#9 nr II

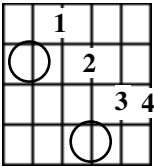

3 b7 #2 #5

C 7#5#9 nr III

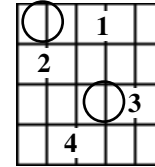

b2#5 b7 3

C 7#5#9 nr III

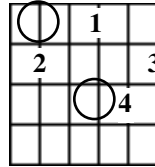

b2 b7 3 #5

C 7#5#9 nr IV

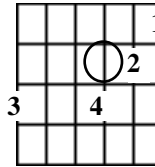

b7 b2 3 #5

C 7#5#9 nr IV

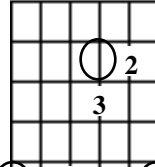

b7 b2 3 #5

C 7#5#9 IV

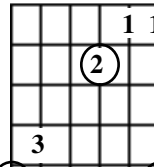

3 b7 1 #2#5

C 7#5#9 nr V

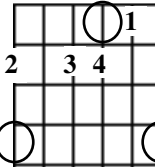

b7 #5 b2 3

C 7#5#9 nr V

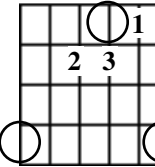

#5 b2 3 b7

C 7#5#9 nr VI

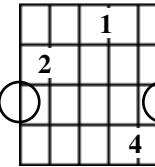

3 b2#5 b7

C 7#5#9 nr VI

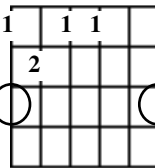

b7 3 #5 b2

C 7#5#9 nr VI

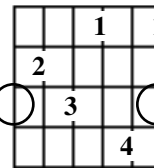

3 b7b2#5b7

C 7#5#9 nr VI

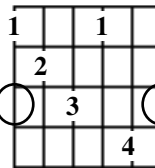

b7 3 b7b2#5

C 7#5#9 nr VI

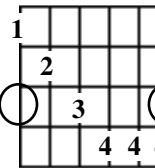

b7 3 b7 3 #5 b2

C 7#5#9 nr VI

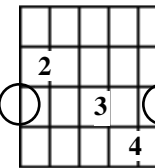

3 #2#5 b7

C 7#5#9 nr VI

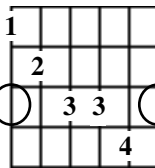

b7 3 b7#2#5

C 7#5#9 nr VI

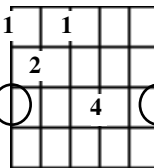

b7 3 #5#2

C 7#5#9 VII

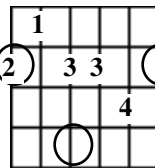

1 3 b7#2#5

C 7#5#9 nr VII

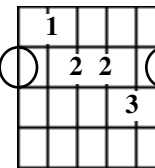

3 b7b3#5

C 7#5#9 nr VII

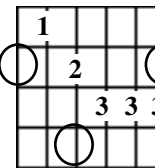

3 b7 3 #5b2

C 7#5#9 VII

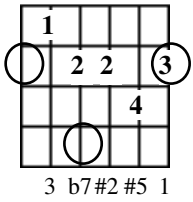

C 7#5#9 nr VII

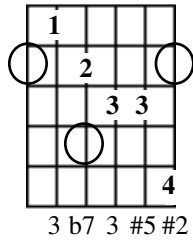

C 7#5#9 VIII

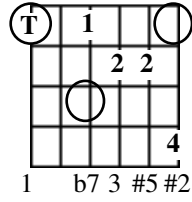

C 7#5#9 nr VIII

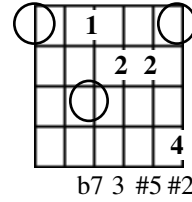

C 7#5#9 nr VIII

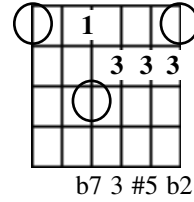

C 7#5#9 IX

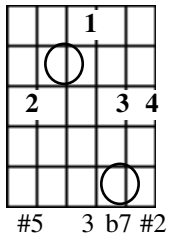

C 7#5#9 nr IX

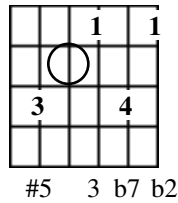

C 7#5#9 nr IX

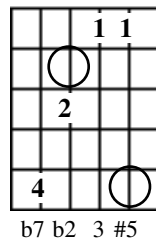

C 7#5#9 nr IX

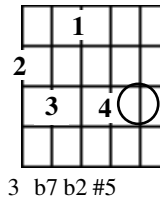

C 7#5#9 nr IX

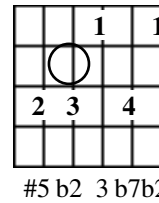

C 7#5#9 nr XI

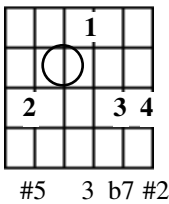

C 7#5#9 XI

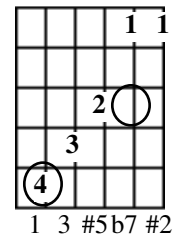

C 7#5#9 nr XI

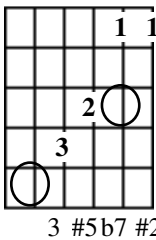

C 7#5#9 nr XI

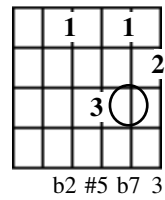

C 7#5#9 nr XI

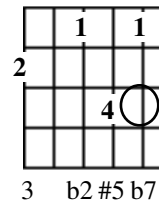

C 7#5#9 nr XII

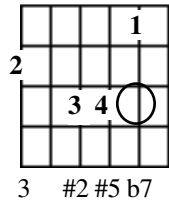

C 7#5#9 XII

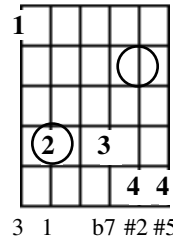

C 7#5#9 nr XII

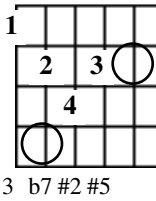



# dominant ninth

C 9 nr I  b7 3 b 2	C 9 nr I  b7 3 2	C 9 II  1 3 b7 2 5	C 9 II  1 3 b7 2	C 9 nr II  5 3 b7 2
C 9 nr II  5 3 b7 2 5	C 9 nr II  3 b7 2	C 9 nr II  3 b7 2 5	C 9 nr II  b7 2 3	C 9 nr III  3 5 b7 2 5
C 9 nr III  3 5 b7 2	C 9 nr III  b7 3 5 b7 2	C 9 nr V  5 2 3 b7	C 9 V  1 b7 2 3	C 9 nr V  5 b7 2 3
C 9 nr V  2 3 b7	C 9 nr VI  3 2 b7	C 9 nr VI  b7 3 2	C 9 nr VI  3 2 5 b7	C 9 VII  1 3 b7 2 5
C 9 nr VII  3 b7 2	C 9 nr VIII  3 b7 2 5	C 9 nr VIII  b7 3 5 2	C 9 VIII  1 b7 3 5 2	C 9 nr VIII  b7 3 2

C 9 IX

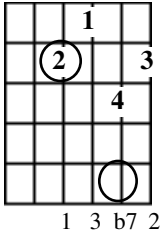

C 9 nr IX

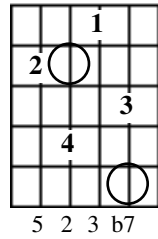

C 9 nr IX

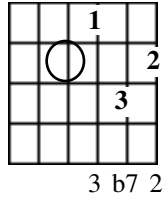

C 9 nr IX

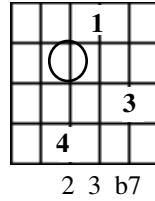

C 9 nr X

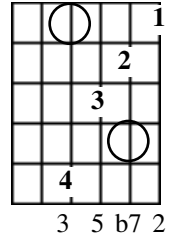

C 9 X

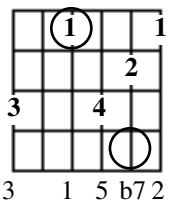

C 9 nr XI

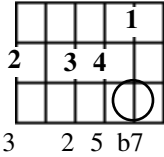

C 9 nr XII

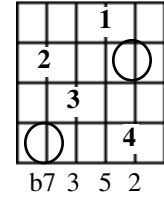

C 9 nr XII

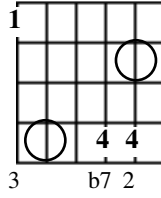

C 9 nr XII

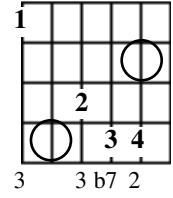

C 9 XII

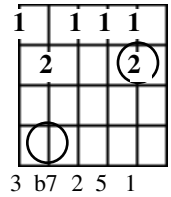

# dominant ninth no third

C 9n3 nr III

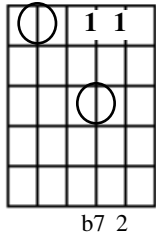

C 9n3 nr III

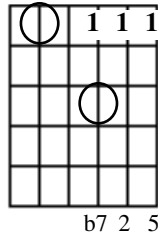

C 9n3 nr III

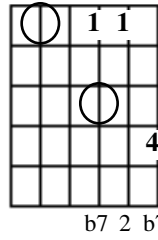

C 9n3 nr III

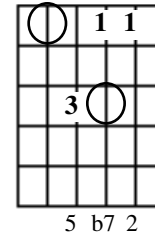

C 9n3 nr III

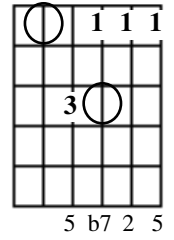

C 9n3 nr III

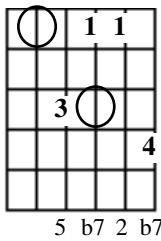

C 9n3 III

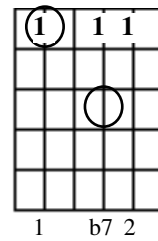

C 9n3 III

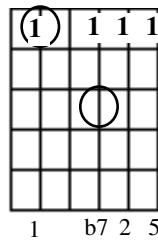

C 9n3 III

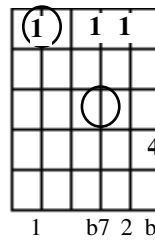

C 9n3 III

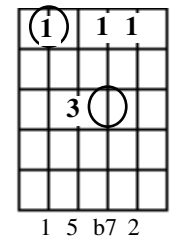

C 9n3 III

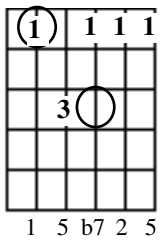

C 9n3 III

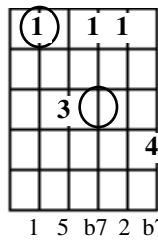

C 9n3 nr III

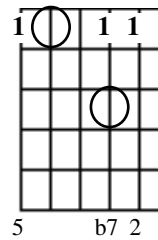

C 9n3 nr III

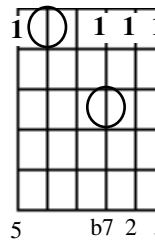

C 9n3 nr III

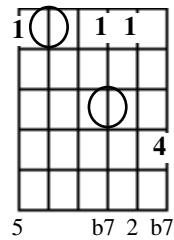

C 9n3 nr III

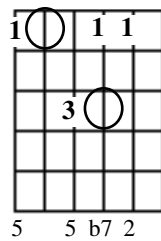

C 9n3 nr III

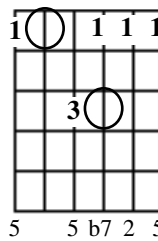

C 9n3 nr III

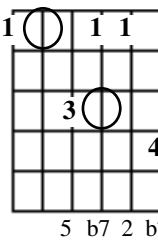

C 9n3 III

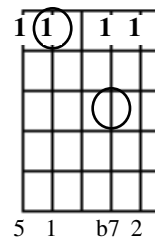

C 9n3 III

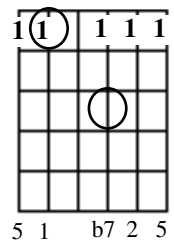

C 9n3 III

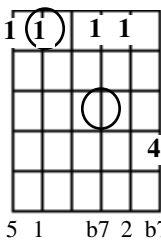

C 9n3 III

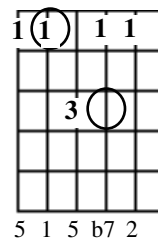

C 9n3 III

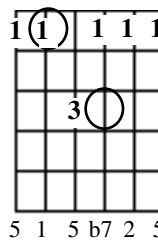

C 9n3 III

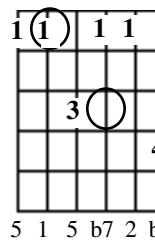

C 9n3 nr III

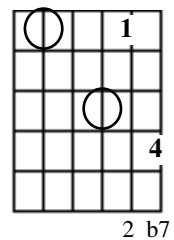

C 9n3 III

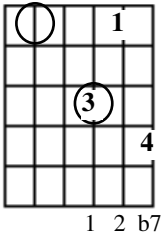

C 9n3 nr III

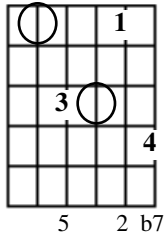

C 9n3 III

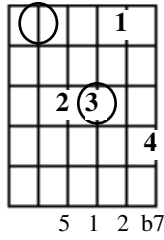

C 9n3 III

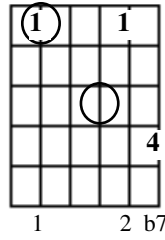

C 9n3 III

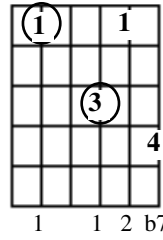

C 9n3 III

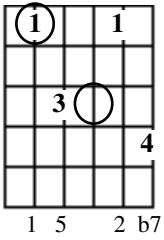

C 9n3 III

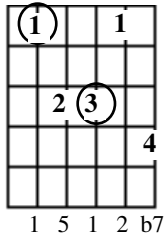

C 9n3 nr III

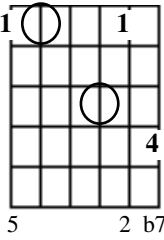

C 9n3 III

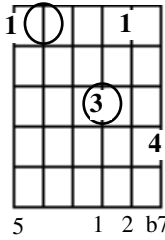

C 9n3 nr III

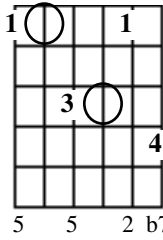

C 9n3 III

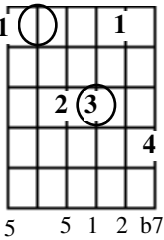

C 9n3 III

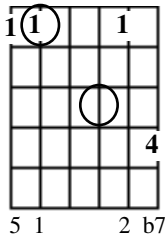

C 9n3 III

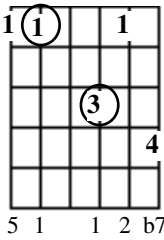

C 9n3 III

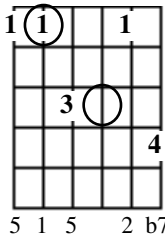

C 9n3 III

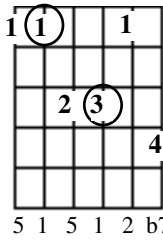

C 9n3 nr V

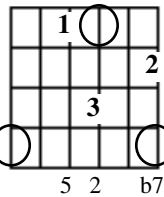

C 9n3 nr V

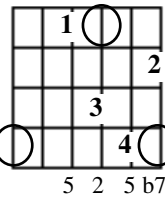

C 9n3 V

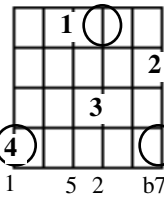

C 9n3 nr VI

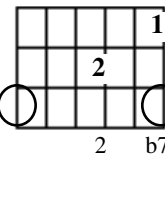

C 9n3 VI

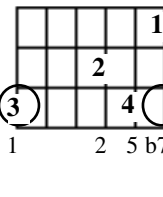

C 9n3 VI

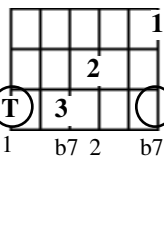

C 9n3 VI

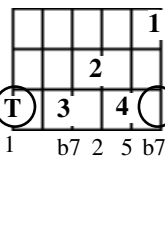

C 9n3 nr VII

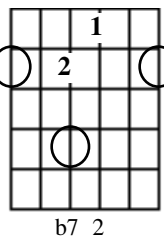

C 9n3 nr VII

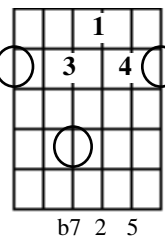

C 9n3 VII

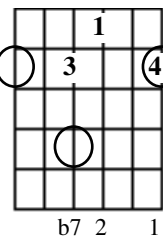

C 9n3 VII

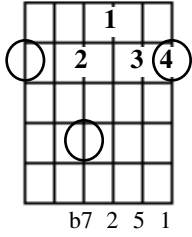

C 9n3 VII

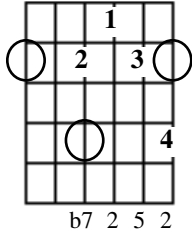

C 9n3 nr VII

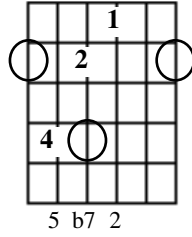

C 9n3 nr VII

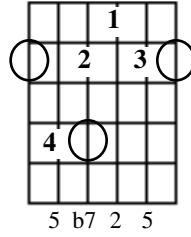

C 9n3 VII

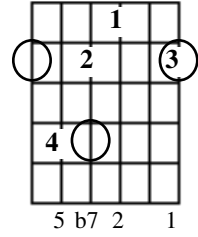

C 9n3 nr VII

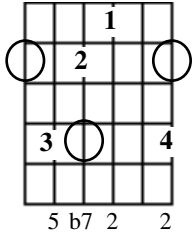

C 9n3 VII

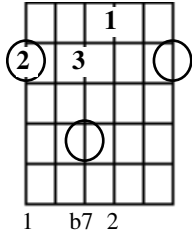

C 9n3 VII

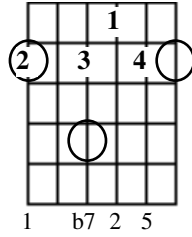

C 9n3 VII

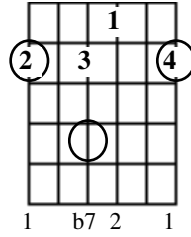

C 9n3 VII

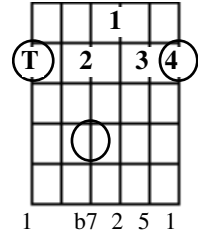

C 9n3 VII

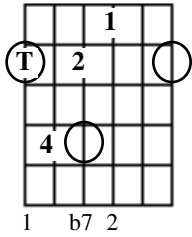

C 9n3 VIII

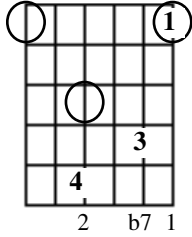

C 9n3 VIII

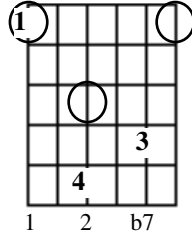

C 9n3 VIII

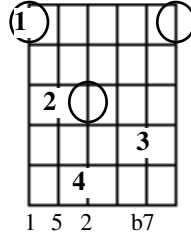

C 9n3 VIII

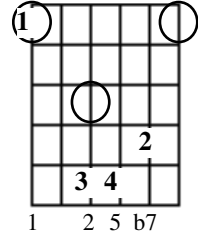

C 9n3 VIII

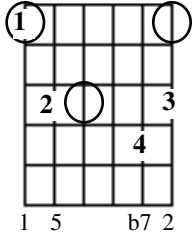

C 9n3 VIII

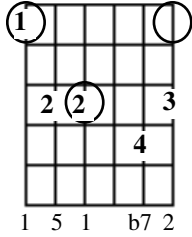

C 9n3 VIII

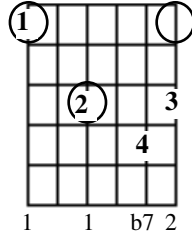

C 9n3 nr X

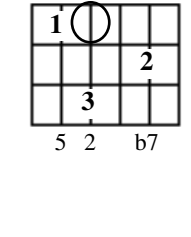

C 9n3 nr X

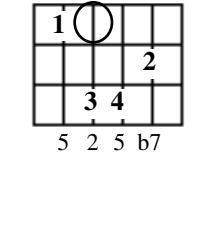

C 9n3 nr X

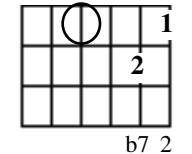

C 9n3 nr X

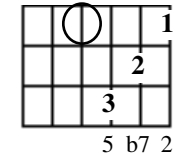

C 9n3 X

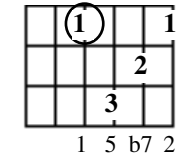

C 9n3 X

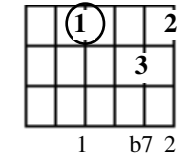

C 9n3 nr X

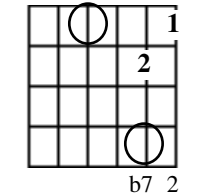

C 9n3 nr X

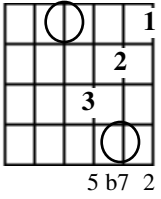

C 9n3 X

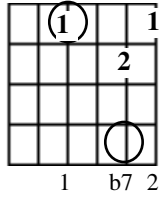

C 9n3 X

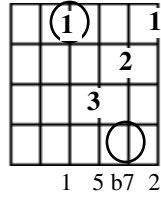

C 9n3 X

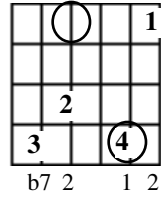

C 9n3 nr X

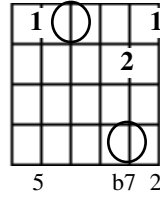

C 9n3 nr X

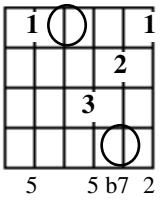

C 9n3 X

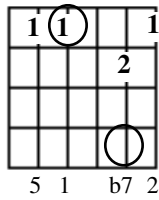

C 9n3 X

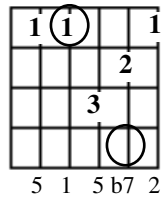

C 9n3 X

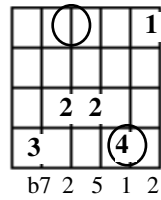

C 9n3 nr XI

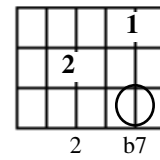

C 9n3 nr XII

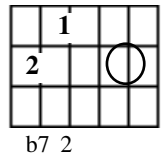

C 9n3 nr XII

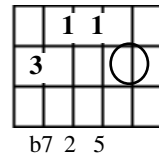

C 9n3 XII

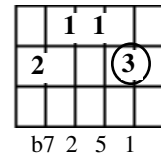

# dominant ninth suspended fourth

C 9sus4

I

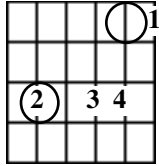

1 b7 2 4

C 9sus4

III

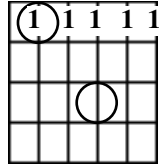

1 4 b7 2 5

C 9sus4

III

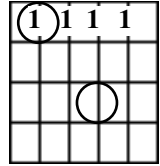

1 4 b7 2

C 9sus4 nr

III

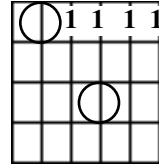

4 b7 2 5

C 9sus4 nr

III

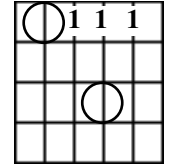

4 b7 2

C 9sus4

VI

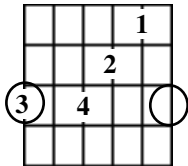

1 b7 2 5

C 9sus4

VI

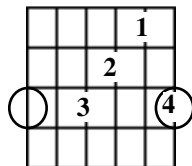

b7 2 4 1

C 9sus4

VI

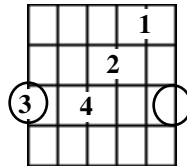

1 b7 2 5

C 9sus4

VIII

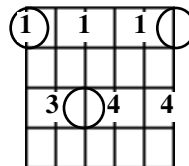

1 5 b7 4 5 2

C 9sus4

X

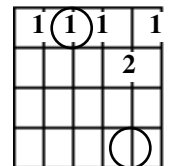

5 1 4 b7 2

# dominant ninth add six

C 9/6 nr I

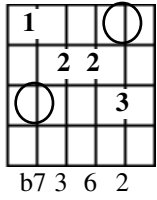

C 9/6 II

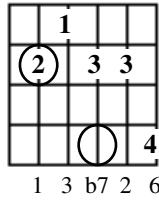

C 9/6 nr II

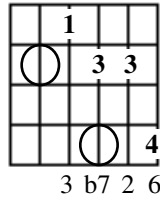

C 9/6 nr II

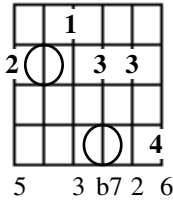

C 9/6 II

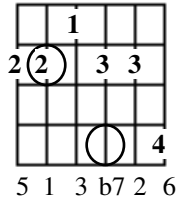

C 9/6 nr II

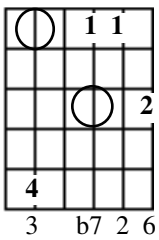

C 9/6 nr III

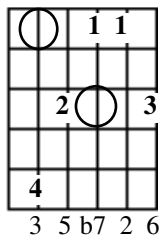

C 9/6 V

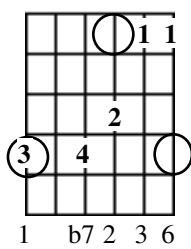

C 9/6 nr V

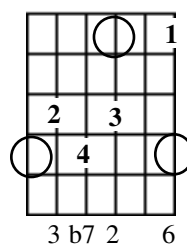

C 9/6 nr V

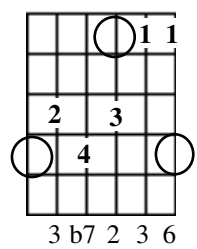

C 9/6 nr V

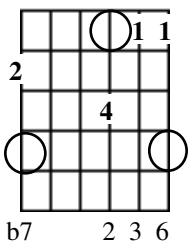

C 9/6 nr V

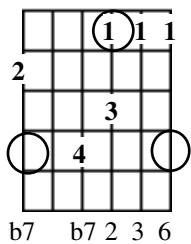

C 9/6 nr V

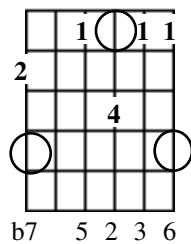

C 9/6 nr V

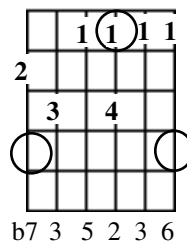

C 9/6 nr VII

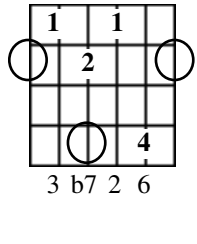

C 9/6 VII

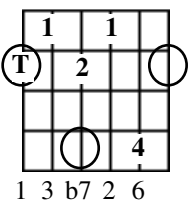

C 9/6 VIII

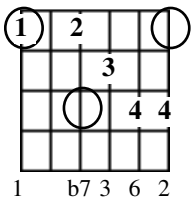

C 9/6 nr VIII

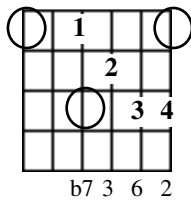

C 9/6 nr X

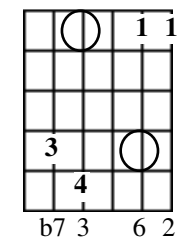

C 9/6 nr X

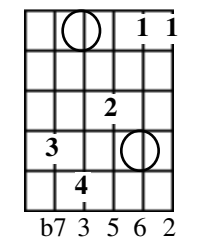



# dominant ninth add six suspended fourth

C 9/6sus4 nr III

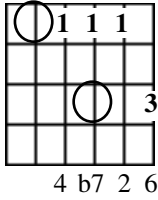

C 9/6sus4 III

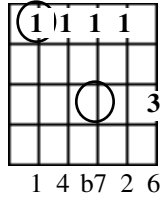

C 9/6sus4 nr III

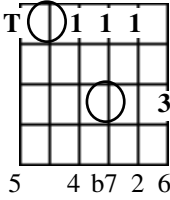

C 9/6sus4 nr III

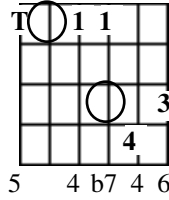

C 9/6sus4 III

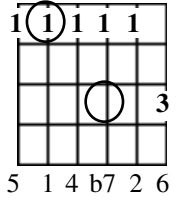

C 9/6sus4 nr V

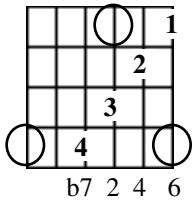

C 9/6sus4 nr VIII

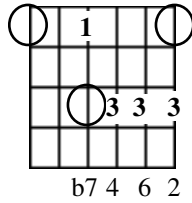

C 9/6sus4 nr VIII

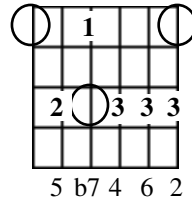

C 9/6sus4 VIII

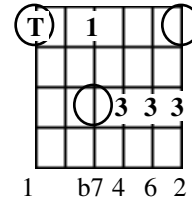

C 9/6sus4 VIII

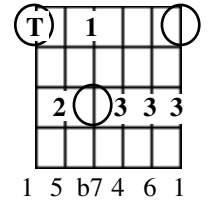

C 9/6sus4 nr X

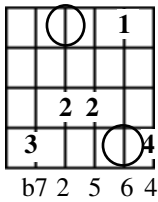

C 9/6sus4 nr X

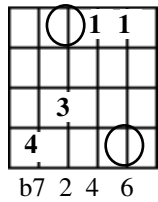

C 9/6sus4 nr X

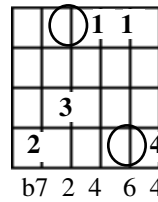

# dominant ninth add six add sharp eleven

C 9/6#11 nr I

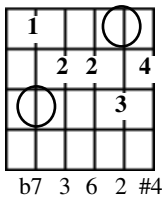

C 9/6#11 nr X

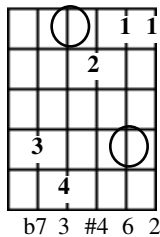

# dominant ninth sharp eleven

C 9#11 II

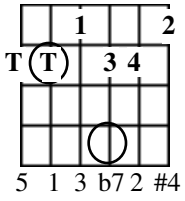

C 9#11 nr II

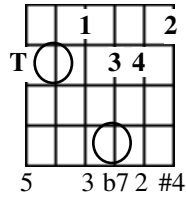

C 9#11 nr II

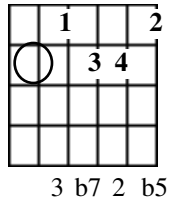

C 9#11 II

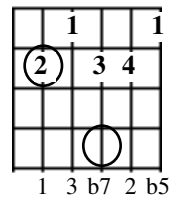

C 9#11 II

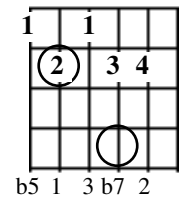

C 9#11 II

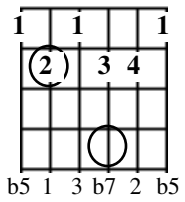

C 9#11 nr III

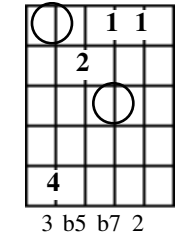

C 9#11 nr IV

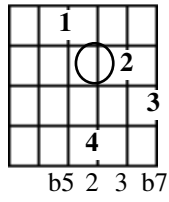

C 9#11 nr VI

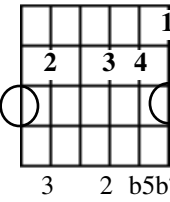

C 9#11 nr VII

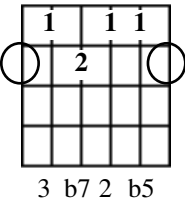

C 9#11 VII

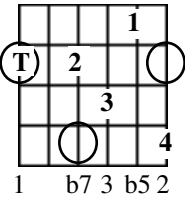

C 9#11 VIII

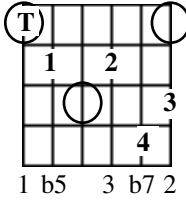

C 9#11 VIII

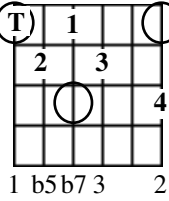

C 9#11 IX

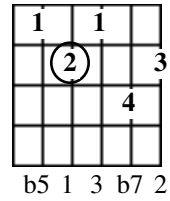

C 9#11 X

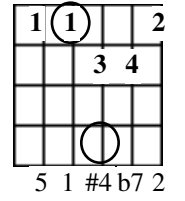

C 9#11 nr X

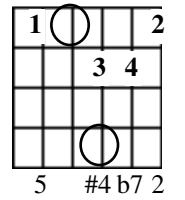

C 9#11 X

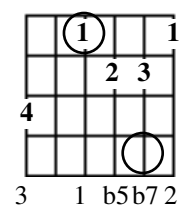

C 9#11 nr XI

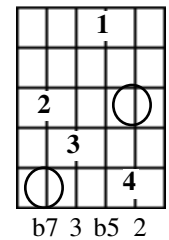

C 9#11 nr XII

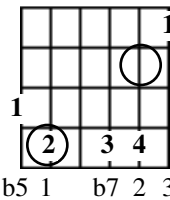

# dominant ninth flat five

C 9b5 nr II

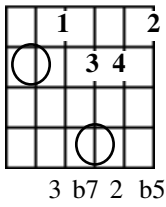

C 9b5 II

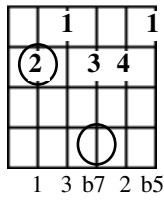

C 9b5 II

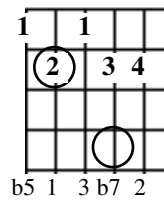

C 9b5 II

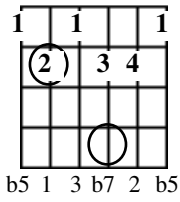

C 9b5 nr III

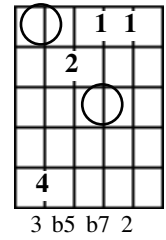

C 9b5 nr IV

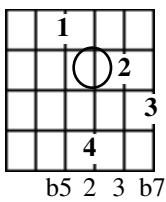

C 9b5 nr VI

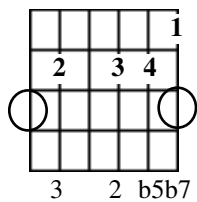

C 9b5 nr VII

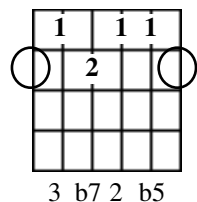

C 9b5 VII

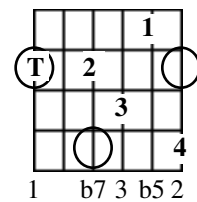

C 9b5 VIII

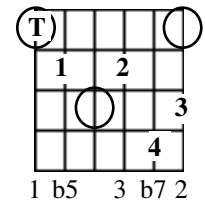

C 9b5 VIII

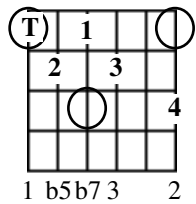

C 9b5 IX

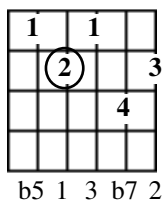

C 9b5 X

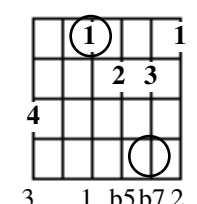

C 9b5 nr XI

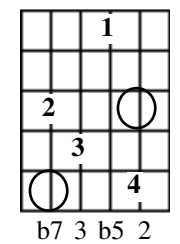

C 9b5 nr XII

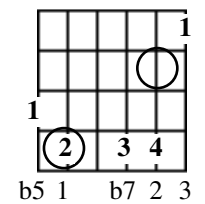

## dominant ninth sharp five

C 9#5 nr I

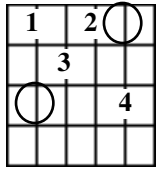

b7 3 #5 2

C 9#5 I

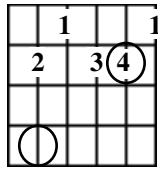

b7 2 #5 1 3

C 9#5 I

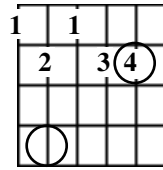

3 b7 2 #5 1

C 9#5 I

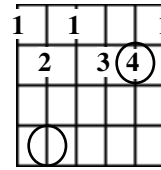

3 b7 2 #5 1 3

C 9#5 II

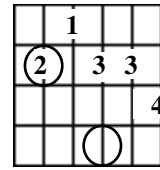

1 3 b7 2 #5

C 9#5 nr III

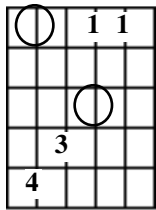

3 #5 b7 2

C 9#5 III

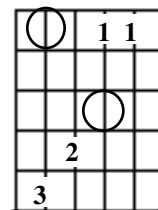

1 3 #5 b7 2

C 9#5 V

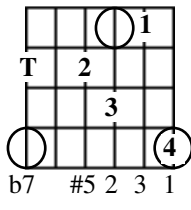

b7 #5 2 3 1

C 9#5 nr VII

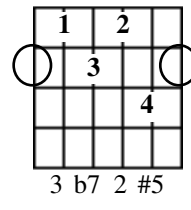

3 b7 2 #5

C 9#5 VII

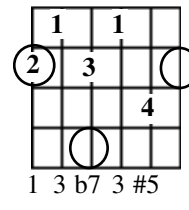

1 3 b7 3 #5

C 9#5 VII

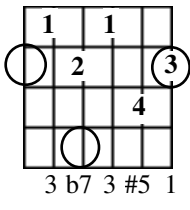

3 b7 3 #5 1

C 9#5 nr VIII

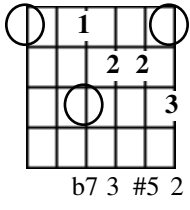

b7 3 #5 2

C 9#5 VIII

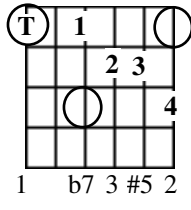

1 b7 3 #5 2

C 9#5 nr X

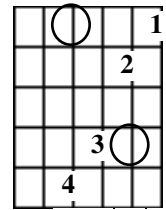

3 #5 b7 2

C 9#5 X

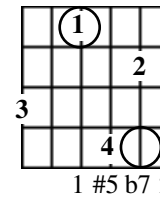

1 #5 b7 2

## dominant ninth flat five sharp five

C 9b5#5 nr I

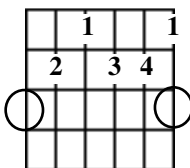

3 #5 2 b5b7

C 9b5#5 nr II

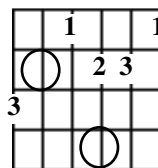

#5 3 b7 2 b5

C 9b5#5 II

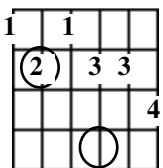

b5 1 3 b7 2 #5

C 9b5#5 VIII

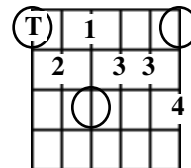

1 b5b7 3 #5 2

## dominant ninth add six flat five

C 9/6b5 nr I      C 9/6b5 II      C 9/6b5 nr X

b7 3 6 2 b5      b5 1 3 b7 2 6      b7 3 b5 6 2

## dominant eleventh no third

C 11n3 I      C 11n3 III      C 11n3 III      C 11n3 VI      C 11n3 VI

1 b7 2 4      1 4 b7 2 5      1 4 b7 2      1 b7 2 5      b7 2 4 1

C 11n3 VI      C 11n3 VIII      C 11n3 X

1 b7 2 5      1 5 b7 4 5 2      5 1 4 b7 2

# dominant thirteenth

C 13 I

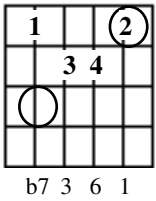

C 13 nr I

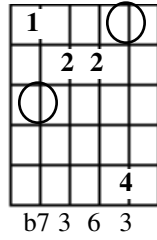

C 13 nr I

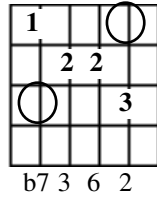

C 13 nr I

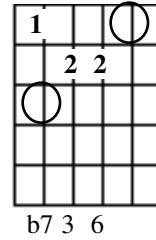

C 13 nr I

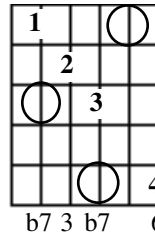

C 13 I

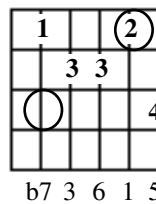

C 13 nr I

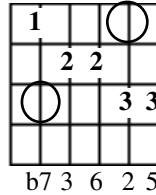

C 13 II

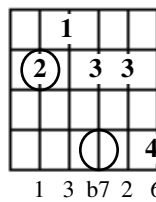

C 13 nr II

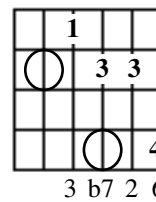

C 13 nr II

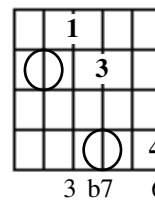

C 13 II

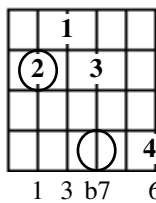

C 13 nr II

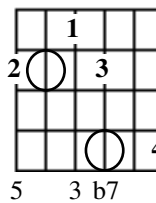

C 13 II

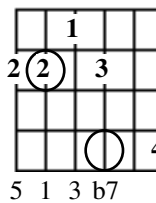

C 13 II

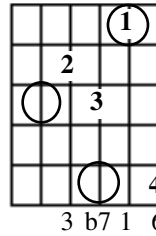

C 13 nr II

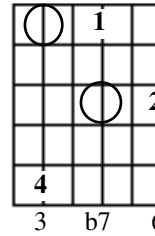

C 13 nr II

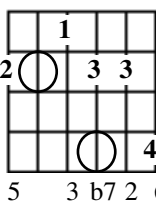

C 13 II

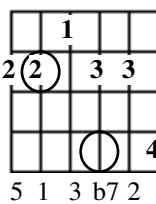

C 13 II

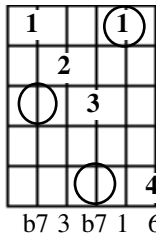

C 13 nr II

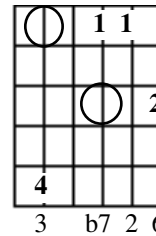

C 13 nr II

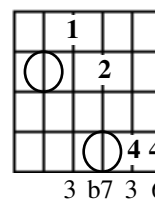

C 13 II

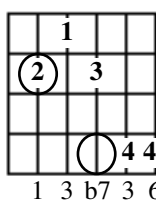

C 13 nr III

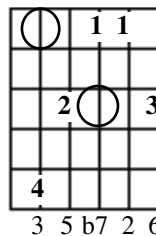

C 13 V

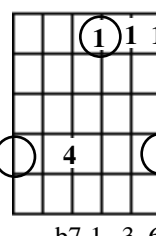

C 13 V

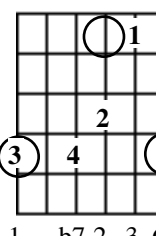

C 13 V

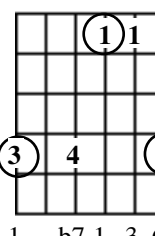

C 13 nr V  b7 3 6	C 13 V  1 b7 3 6	C 13 nr V  3 b7 6	C 13 nr V  3 b7 5 6	C 13 V  3 b7 1 5 6
C 13 nr V  3 b7 2 6	C 13 nr V  3 b7 2 3 6	C 13 nr V  b7 3 6	C 13 nr V  b7 2 3 6	C 13 nr V  b7 3 b7 2 3 6
C 13 V  b7 1 3 6	C 13 V  b7 b7 1 3 6	C 13 nr V  b7 b7 2 3 6	C 13 V  b7 5 1 3 6	C 13 nr V  b7 5 2 3 6
C 13 V  b7 3 5 1 3 6	C 13 nr V  b7 3 5 2 3 6	C 13 nr VII  3 b7 2 6	C 13 nr VII  3 b7 3 6	C 13 VII  1 3 b7 3 6
C 13 VII  1 3 b7 2 6	C 13 VIII  1 b7 3 6	C 13 nr VIII  b7 3 6	C 13 VIII  1 b7 3 6 2	C 13 nr VIII  5 b7 3 6

C 13 VIII

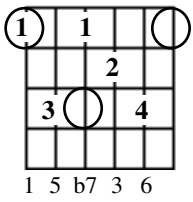

C 13 VIII

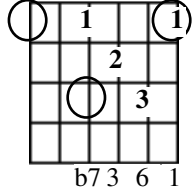

C 13 VIII

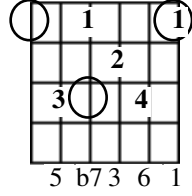

C 13 VIII

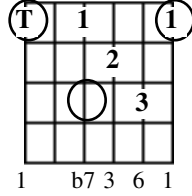

C 13 VIII

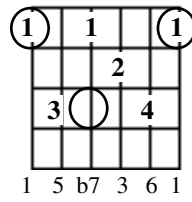

C 13 nr VIII

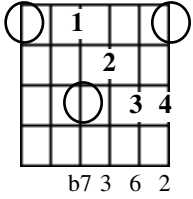

C 13 nr X

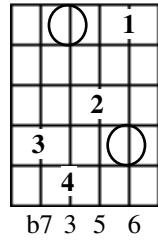

C 13 nr X

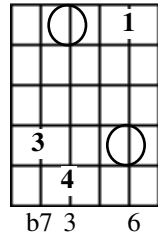

C 13 nr X

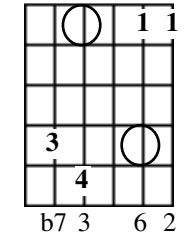

C 13 nr X

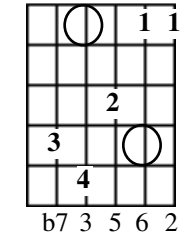

C 13 XII

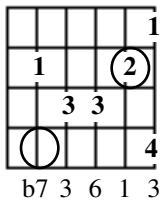



# dominant thirteenth suspended fourth

C 13sus4 nr III

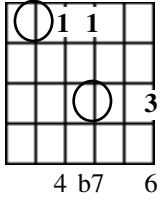

C 13sus4 nr III

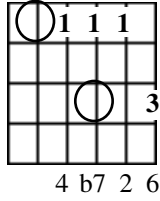

C 13sus4 nr III

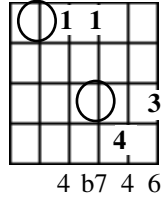

C 13sus4 III

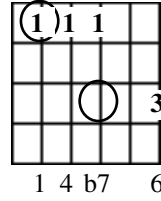

C 13sus4 III

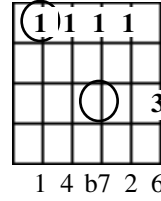

C 13sus4 III

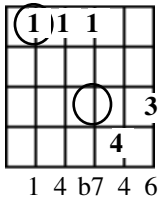

C 13sus4 nr III

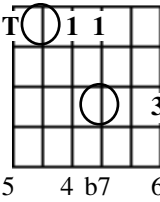

C 13sus4 nr III

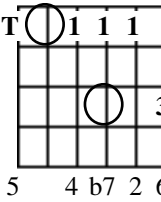

C 13sus4 nr III

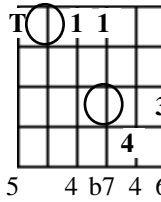

C 13sus4 III

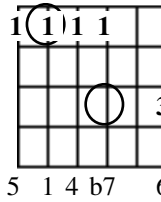

C 13sus4 III

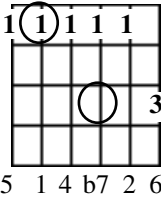

C 13sus4 III

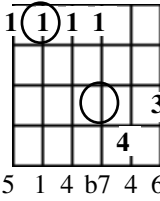

C 13sus4 nr III

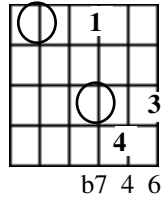

C 13sus4 III

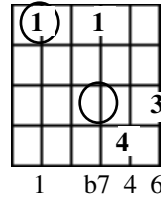

C 13sus4 nr III

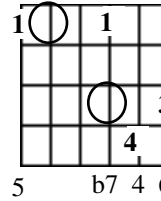

C 13sus4 nr V

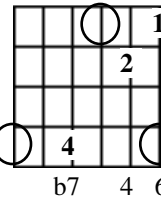

C 13sus4 V

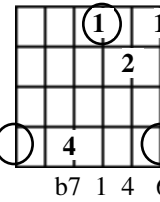

C 13sus4 nr V

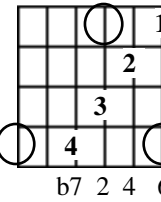

C 13sus4 V

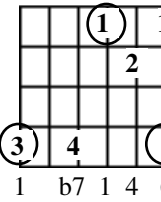

C 13sus4 V

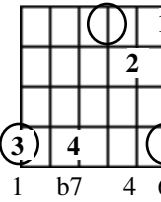

C 13sus4 nr VIII

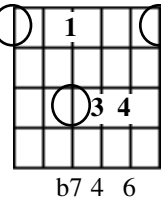

C 13sus4 VIII

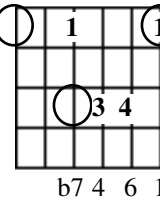

C 13sus4 nr VIII

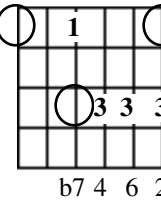

C 13sus4 nr VIII

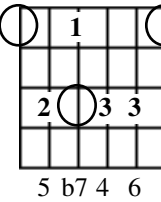

C 13sus4 VIII

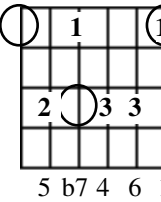

C 13sus4 nr VIII

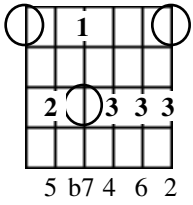

C 13sus4 VIII

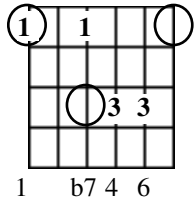

C 13sus4 VIII

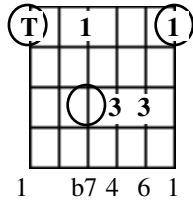

C 13sus4 VIII

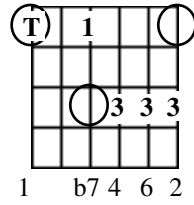

C 13sus4 VIII

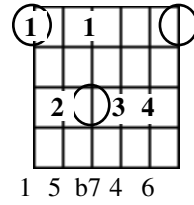

C 13sus4 VIII

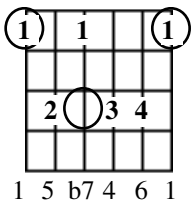

C 13sus4 VIII

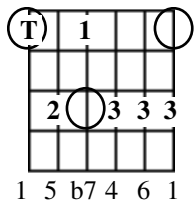

C 13sus4 nr X

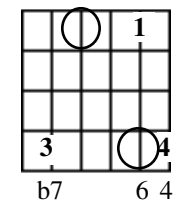

C 13sus4 nr X

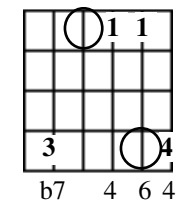

C 13sus4 nr X

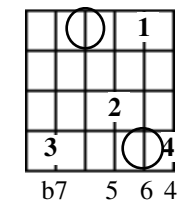

C 13sus4 X

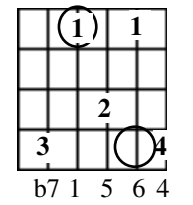

C 13sus4 nr X

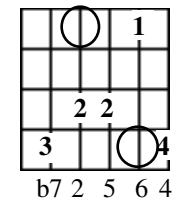

C 13sus4 nr X

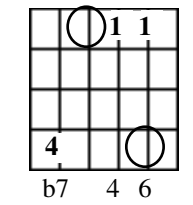

C 13sus4 X

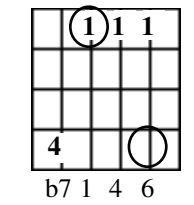

C 13sus4 nr X

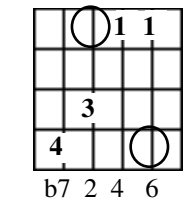

C 13sus4 X

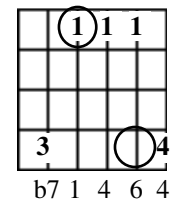

C 13sus4 nr X

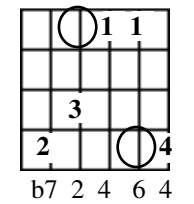

# dominant thirteenth sharp eleventh

C 13#11 nr I

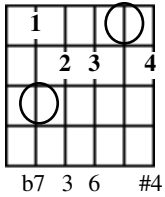

C 13#11 nr I

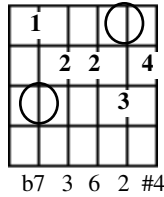

C 13#11 nr III

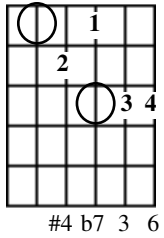

C 13#11 III

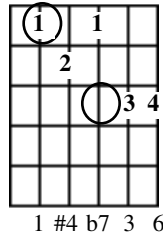

C 13#11 III

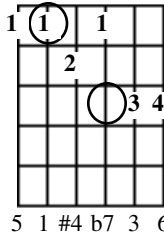

C 13#11 nr III

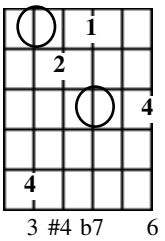

C 13#11 nr V

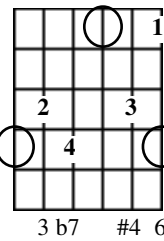

C 13#11 V

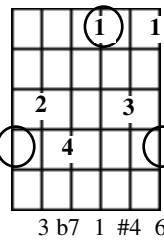

C 13#11 V

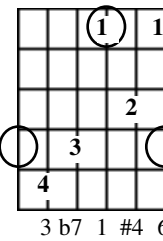

C 13#11 nr V

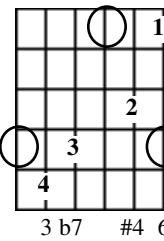

C 13#11 V

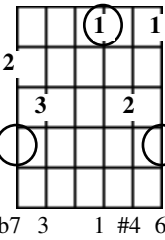

C 13#11 V

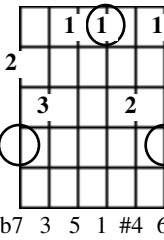

C 13#11 nr VIII

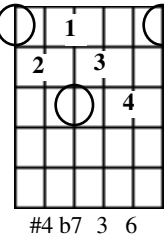

C 13#11 VIII

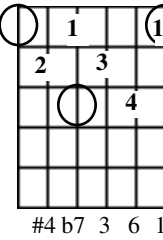

C 13#11 VIII

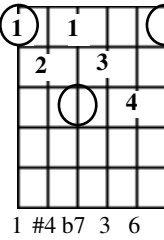

C 13#11 VIII

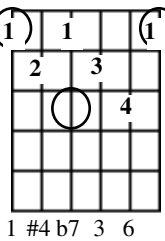

C 13#11 nr VIII

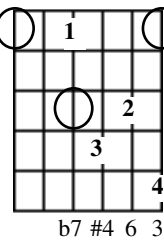

C 13#11 nr VIII

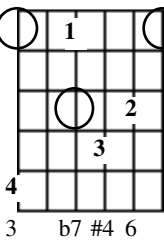

C 13#11 nr X

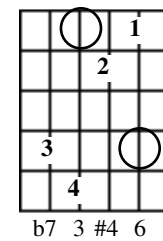

C 13#11 nr X

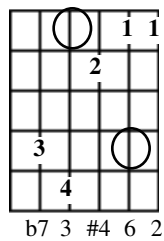

C 13#11 nr XII

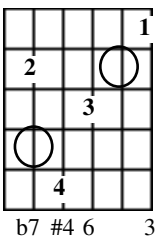

# dominant thirteenth flat nine

C 13b9 nr I

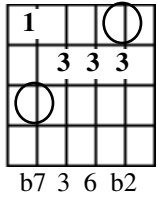

C 13b9 nr II

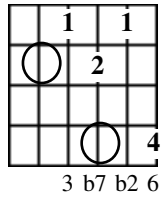

C 13b9 II

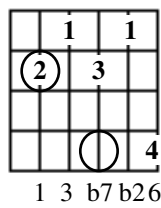

C 13b9 nr II

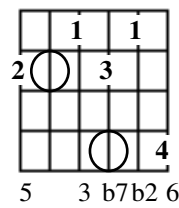

C 13b9 nr V

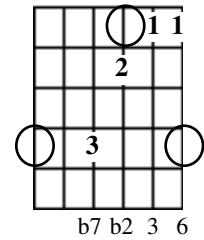

C 13b9 V

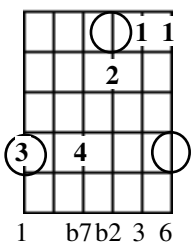

C 13b9 nr V

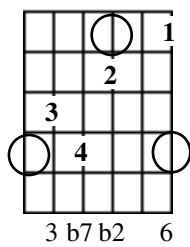

C 13b9 nr V

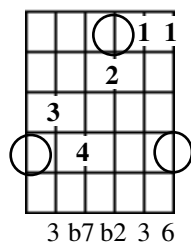

C 13b9 nr V

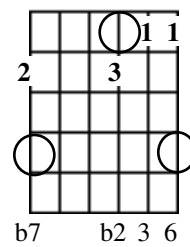

C 13b9 nr V

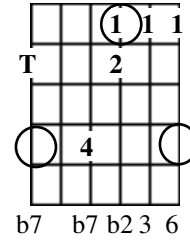

C 13b9 nr V

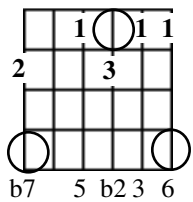

C 13b9 nr V

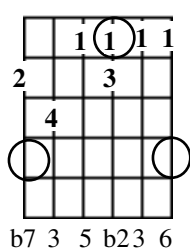

C 13b9 nr VI

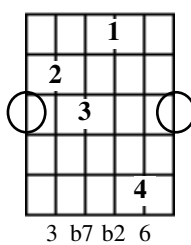

C 13b9 nr VIII

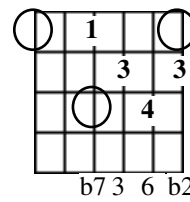

C 13b9 nr VIII

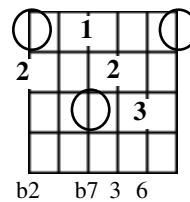

C 13b9 VIII

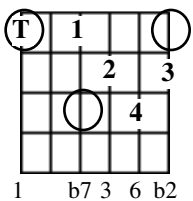

## dominant thirteenth flat five flat nine

C 13b5b9 nr I      C 13b5b9 II      C 13b5b9 nr V      C 13b5b9 nr V      C 13b5b9 nr VIII

The diagrams show the following chord voicings and fingerings:

- I:** Fretboard from 1st to 6th fret. Fingerings: 1 (1st fret), 2 (2nd fret), 3 (3rd fret), 3 (3rd fret), 3 (3rd fret). Notes: b5, b7, 3, 6, b2.
- II:** Fretboard from 1st to 6th fret. Fingerings: 1 (1st fret), 1 (1st fret), 1 (1st fret), 2 (2nd fret), 3 (3rd fret), 4 (4th fret). Notes: b5, 1, 3, b7, b2, 6.
- V:** Fretboard from 1st to 6th fret. Fingerings: 1 (5th fret), 1 (5th fret), 2 (4th fret), 3 (3rd fret), 3 (3rd fret), 4 (4th fret). Notes: b5, b7, b2, 3, 6.
- V:** Fretboard from 1st to 6th fret. Fingerings: 1 (5th fret), 2 (4th fret), 3 (3rd fret), 4 (4th fret), 4 (4th fret), 6 (6th fret). Notes: 3, b7, b2, b5, 6.
- VIII:** Fretboard from 1st to 6th fret. Fingerings: 1 (1st fret), 2 (2nd fret), 3 (3rd fret), 3 (3rd fret), 4 (4th fret). Notes: b5, b7, 3, 6, b2.

## dominant thirteenth flat five sharp nine

C 13b5#9 nr I      C 13b5#9 nr II      C 13b5#9 nr VIII

The diagrams show the following chord voicings and fingerings:

- I:** Fretboard from 1st to 6th fret. Fingerings: 1 (1st fret), 2 (2nd fret), 3 (3rd fret), 3 (3rd fret), 4 (4th fret). Notes: b5, b7, 3, 6, #2.
- II:** Fretboard from 1st to 6th fret. Fingerings: T (1st fret), 1 (1st fret), 2 (2nd fret), 3 (3rd fret), 3 (3rd fret), 4 (4th fret). Notes: b5, 3, b7, #2, 6.
- VIII:** Fretboard from 1st to 6th fret. Fingerings: 1 (1st fret), T (1st fret), 2 (2nd fret), 3 (3rd fret), 3 (3rd fret), 4 (4th fret). Notes: b5, b7, 3, 6, #2.

# dominant thirteenth flat nine suspended fourth

C 13b9sus4 I

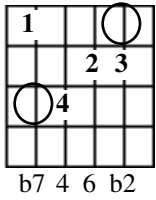

C 13b9sus4 II

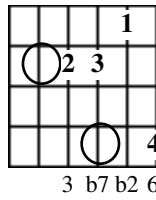

C 13b9sus4 III

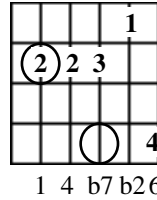

C 13b9sus4 IV

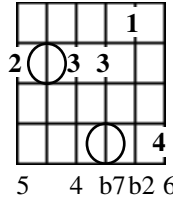

C 13b9sus4 V

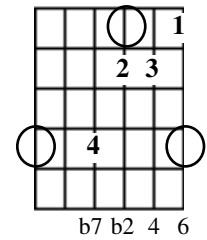

C 13b9sus4 VI

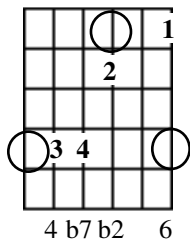

C 13b9sus4 VII

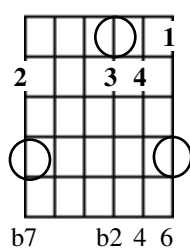

C 13b9sus4 VIII

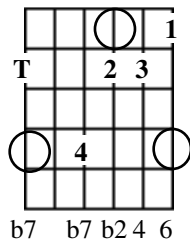

C 13b9sus4 IX

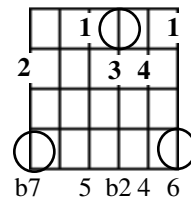

C 13b9sus4 X

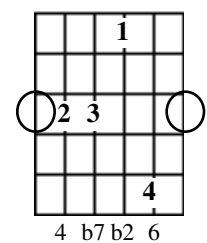

C 13b9sus4 XI

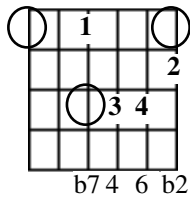

C 13b9sus4 XII

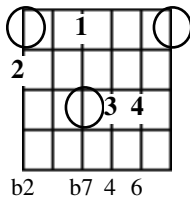

C 13b9sus4 XIII

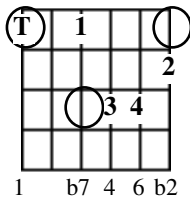

# minor add nine

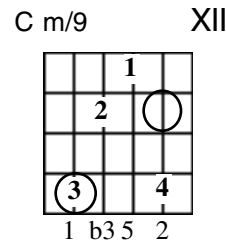
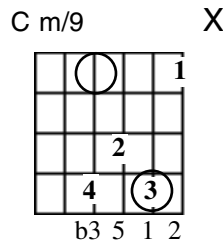
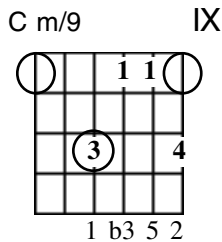
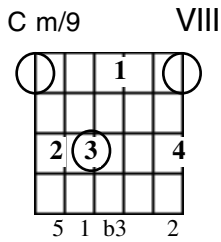
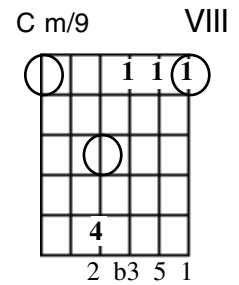
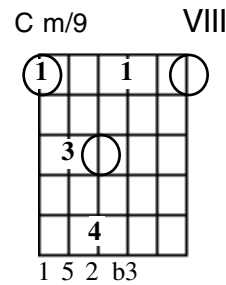
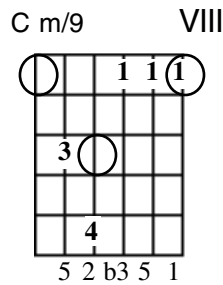
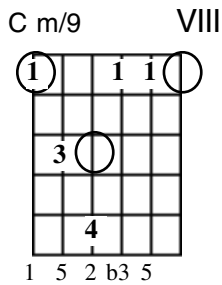
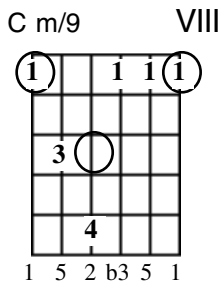
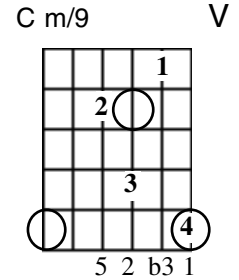
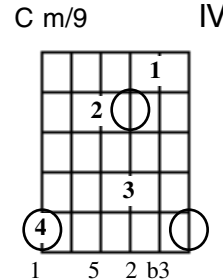
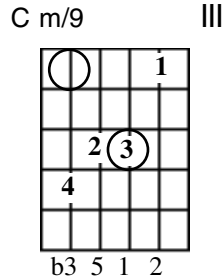
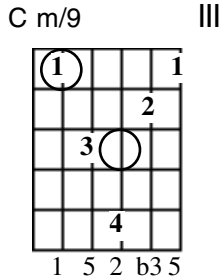
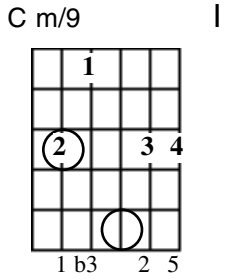

# minor seventh

C m7 I C m7 I C m7 I C m7 I C m7 I

1 b3 b7 1      1 b3 b7 b3 5      1 b3 b7 b3      b3 b7 1 5      b7 b3 1

C m7 I C m7 I C m7 I C m7 nr I C m7 nr I

b3 b7 1      5 b3 b7 1      1 b3 b7      5 b3 b7      b3 b7 5

C m7 nr I C m7 nr I C m7 nr I C m7 I C m7 III

2 b3 1 b3      b7 b3 5      5 b7 b3      5 1 b3 b7      1 5 b7 b3 5

C m7 III C m7 nr III C m7 nr III C m7 nr III C m7 nr III

1 5 b7 b3      5 b7 b3 5      5 b7 b3      b7 b3 5      b3 b7 5

C m7 nr III C m7 nr III C m7 nr III C m7 III C m7 III

b3 5 b7      5 b3 5 b7      5 b3 b7      1 b7 b3 5      1 b7 b3





C m7 VIII

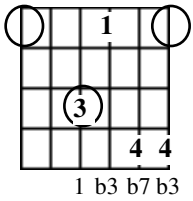

C m7 VIII

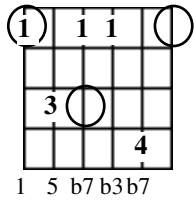

C m7 VIII

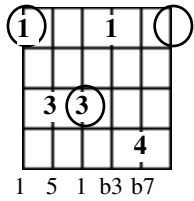

C m7 nr VIII

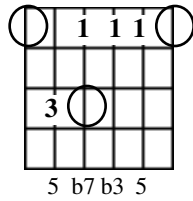

C m7 nr VIII

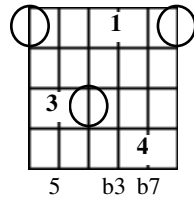

C m7 nr VIII

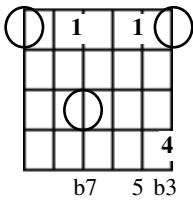

C m7 nr VIII

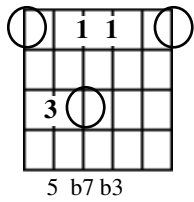

C m7 nr VIII

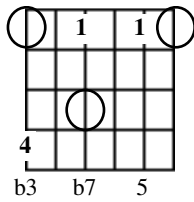

C m7 nr VIII

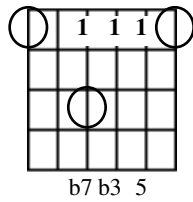

C m7 nr VIII

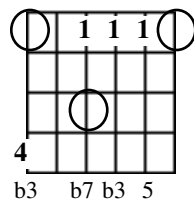

C m7 nr VIII

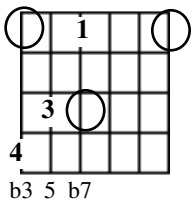

C m7 VIII

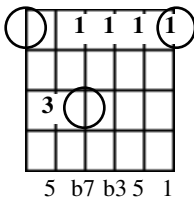

C m7 VIII

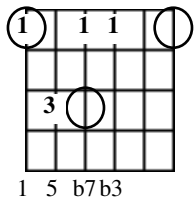

C m7 VIII

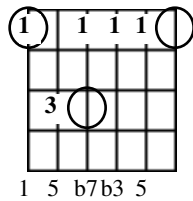

C m7 VIII

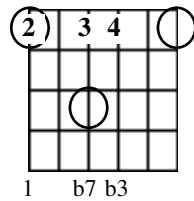

C m7 VIII

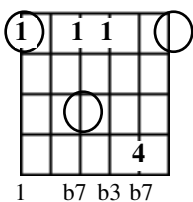

C m7 X

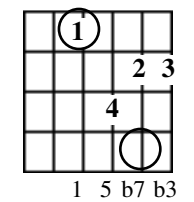

C m7 X

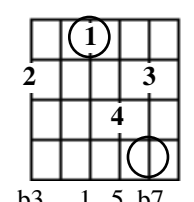

C m7 X

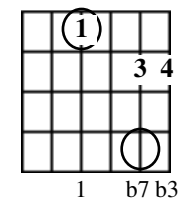

C m7 XI

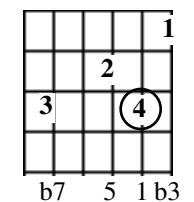

C m7 XI

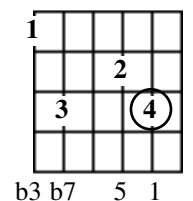

C m7 XI

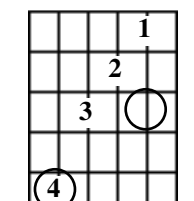

C m7 nr XI

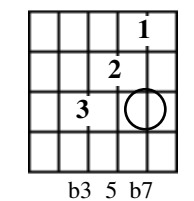

C m7 XI

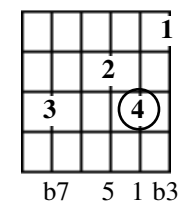

C m7 nr XI

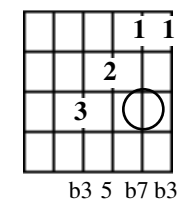

C m7 nr XI

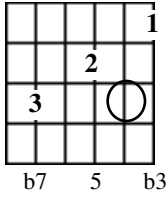

C m7 nr XI

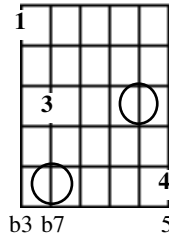

C m7 nr XI

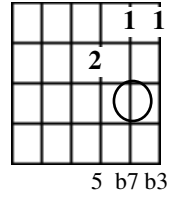

C m7 XII

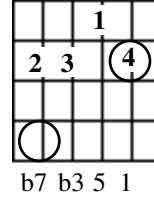

C m7 nr XII

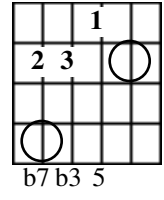

# minor seventh add six

C m7/6 nr I

b3 b7 6

C m7/6 I

b3 b7 1 6

C m7/6 I

1 b3 b7 6

C m7/6 I

1 b3 b7 1 6

C m7/6 nr I

5 b3 b7 6

C m7/6 I

5 b3 b7 1 6

C m7/6 nr I

b3 b7 b3 6

C m7/6 nr II

b7 b3 6

C m7/6 nr II

b7 b3 5 6

C m7/6 nr III

b7 b3 6

C m7/6 III

1 b7 b3 6

C m7/6 nr III

5 b7 b3 6

C m7/6 III

5 1 b7 b3 6

C m7/6 nr III

5 b7 b3 6

C m7/6 III

1 5 b7 b3 6

C m7/6 III

5 1 5 b7 b3 6

C m7/6 nr III

5 5 b7 b3 6

C m7/6 nr V

b7 b3 6

C m7/6 nr V

b7 b3 5 6

C m7/6 nr V

b3 b7 b3 6

C m7/6 V

1 b7 b3 6

C m7/6 V

1 b7 b3 5 6

C m7/6 VIII

1 b7 b3 6

C m7/6 VIII

1 b7 b3 6 1

C m7/6 VIII

1 b7 b3 6 b3

C m7/6 VIII

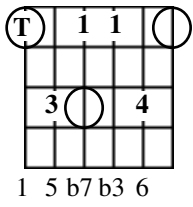

C m7/6 VIII

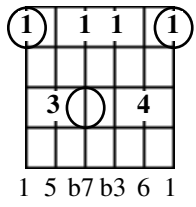

C m7/6 VIII

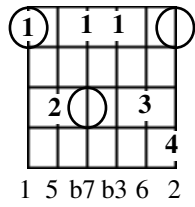

C m7/6 nr VIII

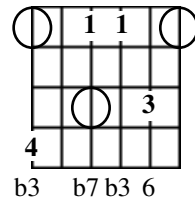

C m7/6 VIII

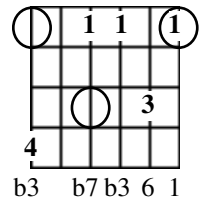

C m7/6 nr VIII

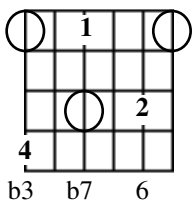

C m7/6 VIII

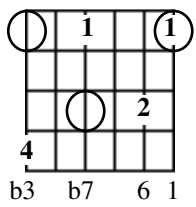

C m7/6 nr VIII

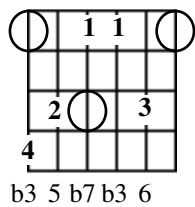

C m7/6 nr VIII

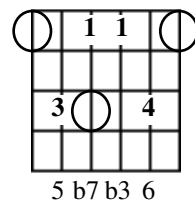

C m7/6 VIII

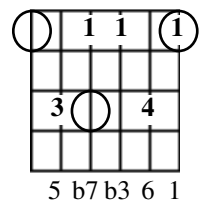

C m7/6 nr VIII

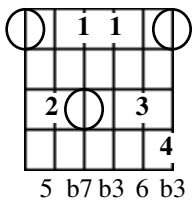

C m7/6 nr VIII

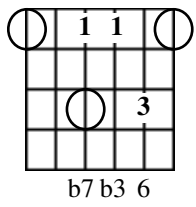

C m7/6 VIII

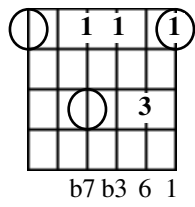

C m7/6 nr VIII

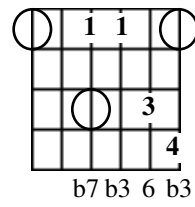

C m7/6 nr X

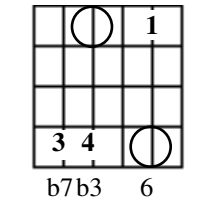

C m7/6 nr X

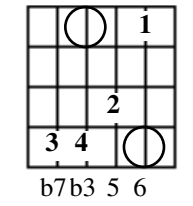

C m7/6 nr X

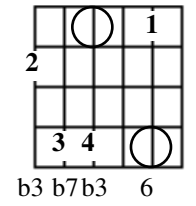

C m7/6 nr X

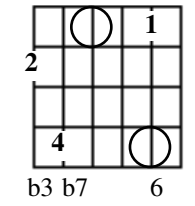

C m7/6 X

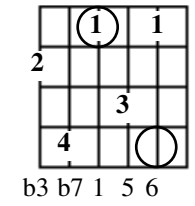

C m7/6 X

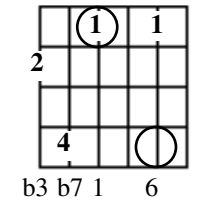

C m7/6 nr X

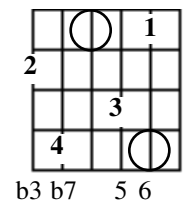

# minor seventh add eleven

C m7/11 I

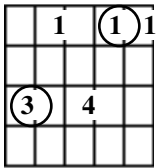

1 b3 b7 1 4

C m7/11 I

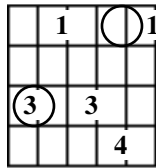

1 b3 b7b3 4

C m7/11 I

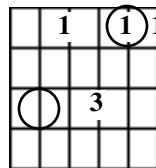

b3 b7 1 4

C m7/11 nr I

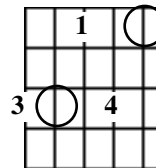

5 b3 b7 4

C m7/11 nr I

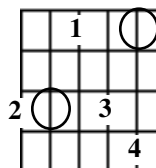

5 b3 1 b3 4

C m7/11 I

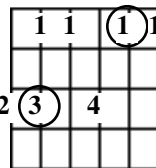

5 b7 b3 b7 1 4

C m7/11 I

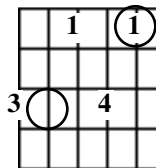

5 b3 b7 1 4

C m7/11 I

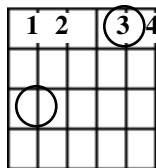

b7 b3 1 4

C m7/11 I

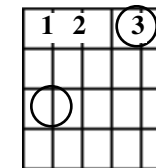

b7 b3 1 4

C m7/11 nr I

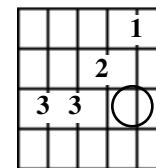

b7 b3 5 b7 4

C m7/11 III

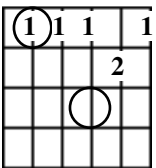

1 4 b7 b3 5

C m7/11 III

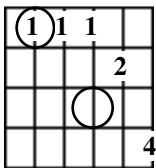

1 4 b7 b3 b7

C m7/11 nr III

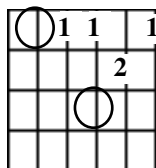

4 b7 b3 5

C m7/11 nr III

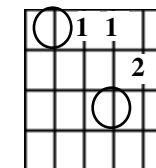

4 b7 b3

C m7/11 nr III

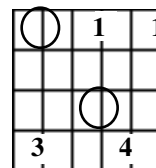

b3 b7 4 5

C m7/11 nr III

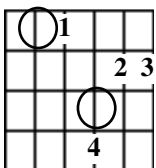

5 b3 4b7

C m7/11 III

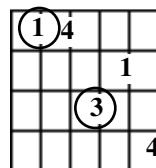

1 4 1 b3 b7

C m7/11 nr III

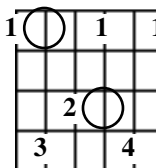

5 b3 5 b7 4 5

C m7/11 nr III

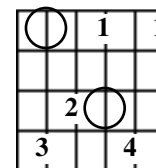

b3 5 b7 4 5

C m7/11 nr III

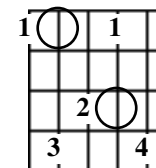

5 b3 5 b7 4

C m7/11 nr III

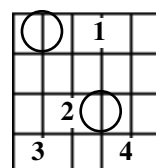

b3 5 b7 4

C m7/11 nr III

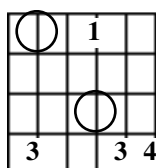

b3 b7 4 b7

C m7/11 III

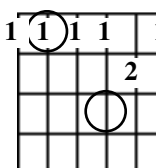

5 1 4 b7 b3 5

C m7/11 III

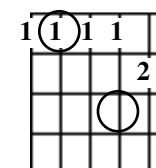

5 1 4 b7 b3

C m7/11 III

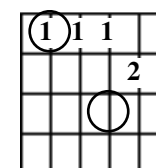

1 4 b7 b3

C m7/11 III

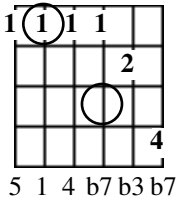

C m7/11 nr III

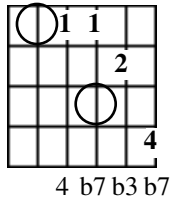

C m7/11 nr III

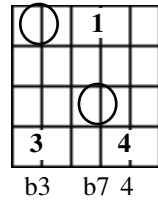

C m7/11 V

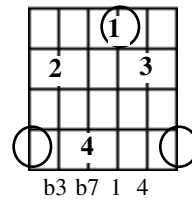

C m7/11 V

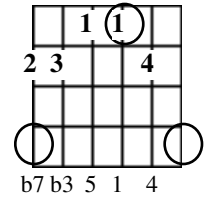

C m7/11 nr V

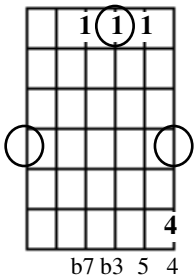

C m7/11 nr V

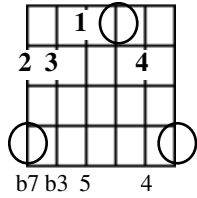

C m7/11 V

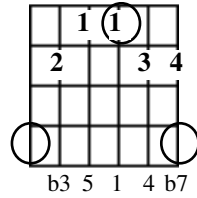

C m7/11 nr V

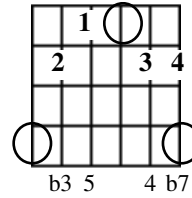

C m7/11 nr VI

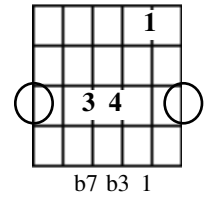

C m7/11 nr VI

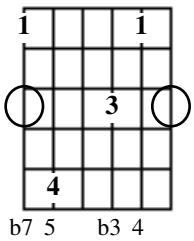

C m7/11 nr VI

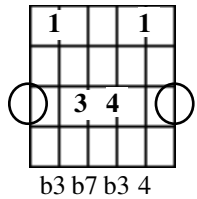

C m7/11 nr VI

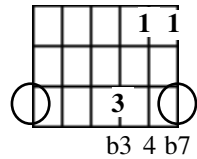

C m7/11 VI

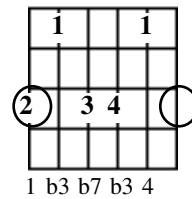

C m7/11 VI

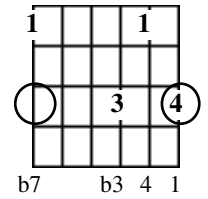

C m7/11 VI

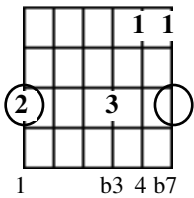

C m7/11 VI

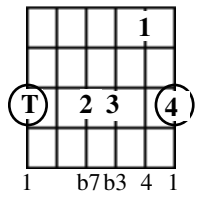

C m7/11 nr VI

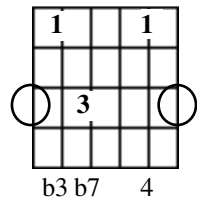

C m7/11 VI

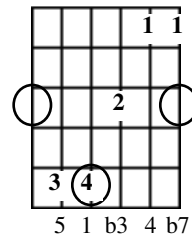

C m7/11 VI

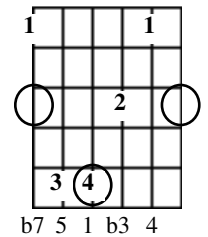

C m7/11 VI

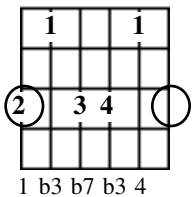

C m7/11 VI

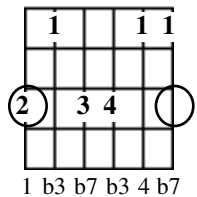

C m7/11 VI

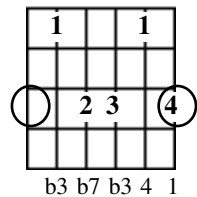

C m7/11 VI

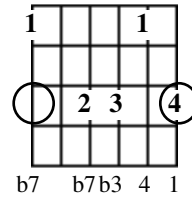

C m7/11 VI

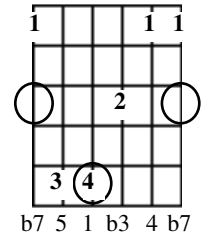

C m7/11 VII

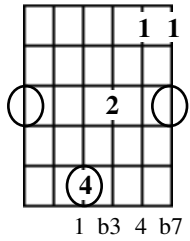

C m7/11 VII

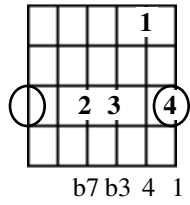

C m7/11 nr VII

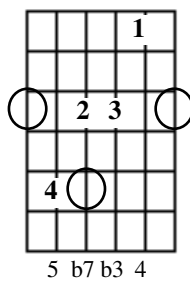

C m7/11 VIII

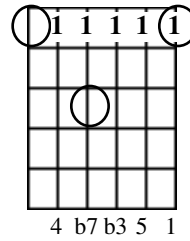

C m7/11 nr VIII

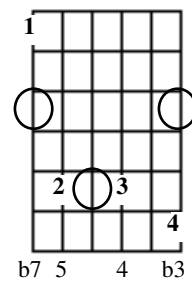

C m7/11 VIII

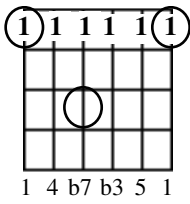

C m7/11 VIII

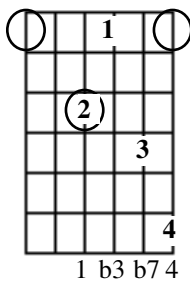

C m7/11 VIII

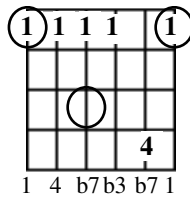

C m7/11 nr VIII

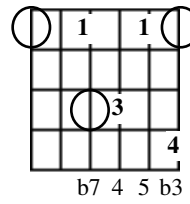

C m7/11 nr VIII

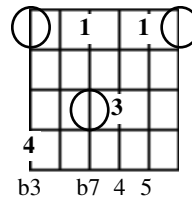

C m7/11 VIII

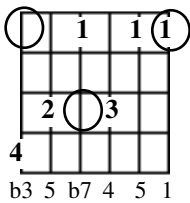

C m7/11 VIII

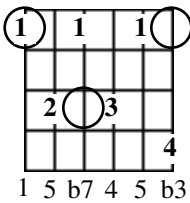

C m7/11 nr VIII

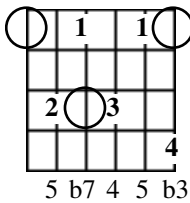

C m7/11 nr VIII

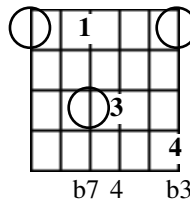

C m7/11 VIII

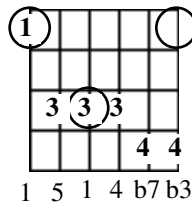

C m7/11 VIII

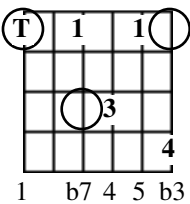

C m7/11 nr VIII

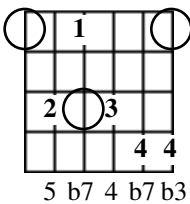

C m7/11 VIII

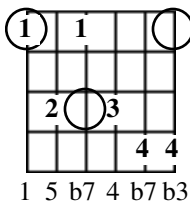

C m7/11 VIII

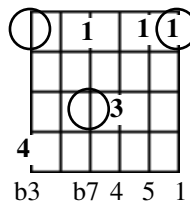

C m7/11 nr VIII

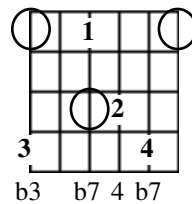

C m7/11 VIII

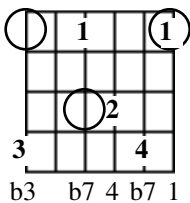

C m7/11 VIII

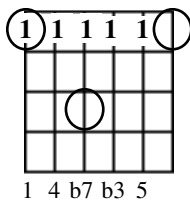

C m7/11 VIII

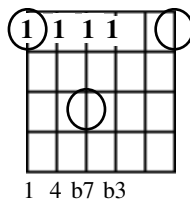

C m7/11 nr VIII

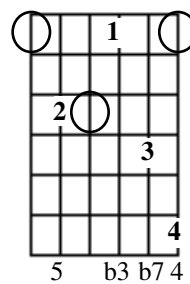

C m7/11 VIII

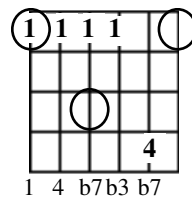



C m7/11 VIII

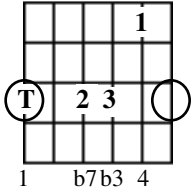

C m7/11 nr IX

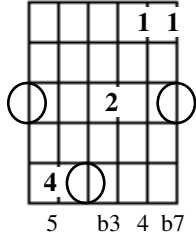

C m7/11 IX

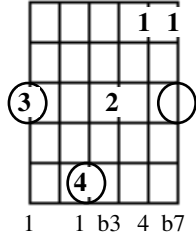

C m7/11 X

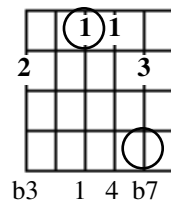

C m7/11 X

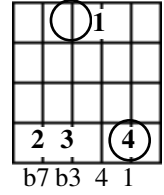

C m7/11 X

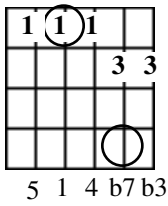

C m7/11 X

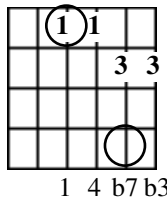

C m7/11 X

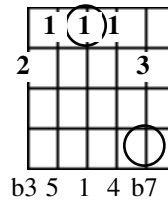

C m7/11 X

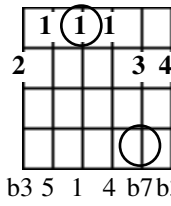

C m7/11 nr X

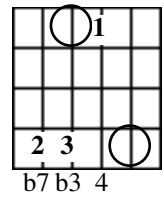

C m7/11 nr X

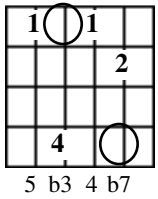

C m7/11 nr XI

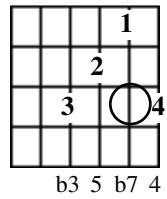

C m7/11 nr XI

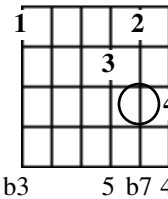

C m7/11 nr XI

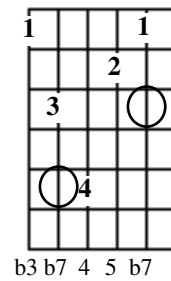

C m7/11 nr XI

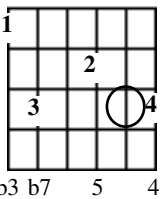

C m7/11 nr XI

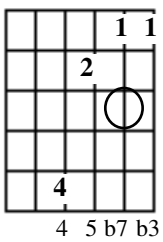

C m7/11 nr XI

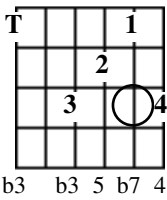

C m7/11 nr XI

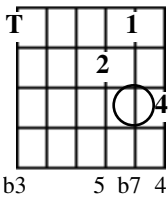

C m7/11 nr XI

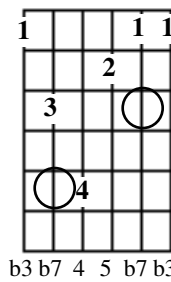

C m7/11 XI

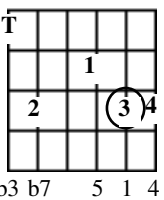

C m7/11 XII

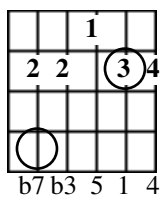

C m7/11 nr XII

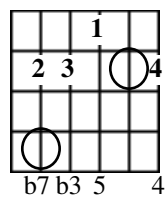

C m7/11 XII

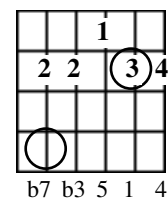

C m7/11 XII

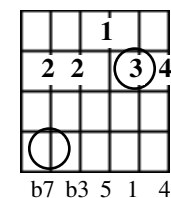

# minor ninth

C m9 I

1 b3 b7 2 5

C m9 I

1 b3 b7 2

C m9 nr I

b3 b7 2

C m9 nr I

5 b3 b7 2

C m9 nr I

b3 b7 2 5

C m9 nr I

5 b3 b7 2 5

C m9 nr I

5 b7 b3 b7 2

C m9 nr II

b7 5 2 b3

C m9 nr III

b3 5 b7 2 5

C m9 nr III

b3 5 b7 2

C m9 nr III

b7 b3 5 b7 2

C m9 nr III

b7 b3 5 b7 2 b3

C m9 nr III

b3 5 b7 2 5

C m9 nr III

b7 2 b3 5

C m9 nr IV

5 2 b3 b7

C m9 IV

b7 2 b3 1

C m9 V

1 b3 b7 2

C m9 V

b3 b7 2 1

C m9 nr V

b7 b3 5 2

C m9 nr VI

b3 2 5 b7

C m9 VI

1 b3 b7 b3 5 2

C m9 nr VI

b3 b7 2 5

C m9 nr VI

b3 b7 2 5 b7

C m9 nr VI

b7 b3 b7 2 5

C m9 nr VI

b3 b7 5 2

C m9 nr VI

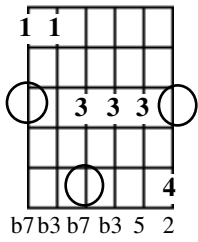

C m9 nr VI

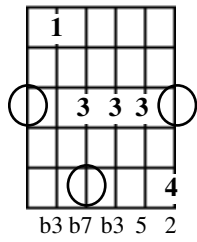

C m9 nr VII

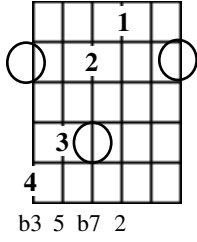

C m9 VIII

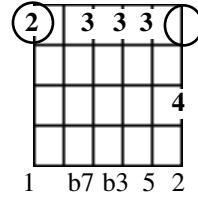

C m9 VIII

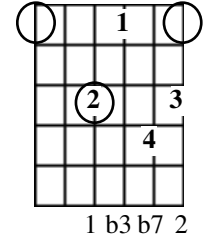

C m9 VIII

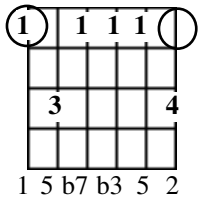

C m9 VIII

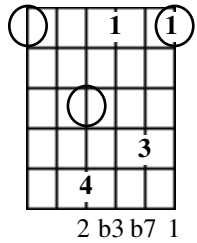

C m9 VIII

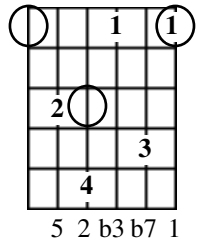

C m9 VIII

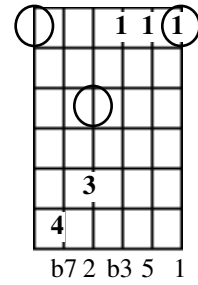

C m9 nr VIII

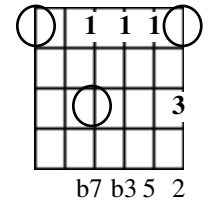

C m9 nr VIII

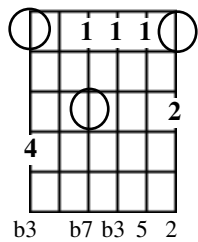

C m9 nr X

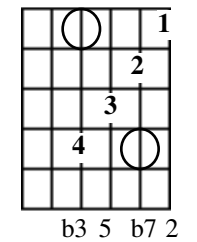

C m9 X

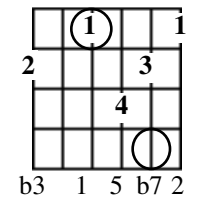

C m9 X

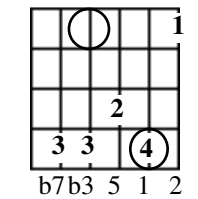

C m9 nr X

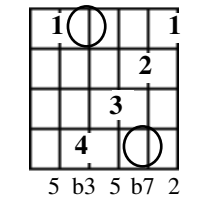

C m9 nr X

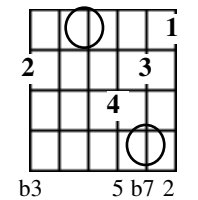

C m9 XI

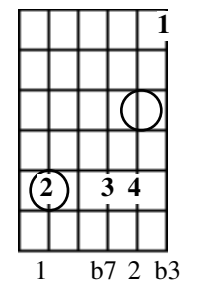

C m9 nr XI

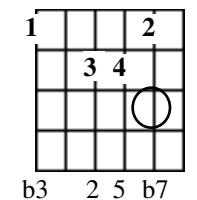

C m9 nr XI

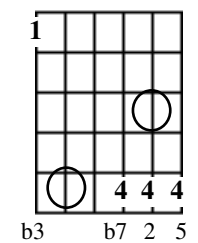

C m9 nr XI

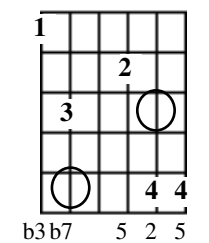

C m9 nr XI

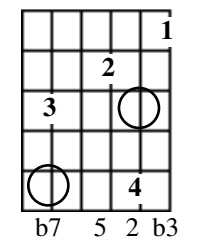

C m9 nr XI

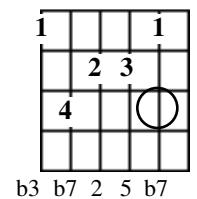

C m9 nr XI

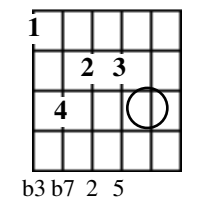

C m9 nr XI

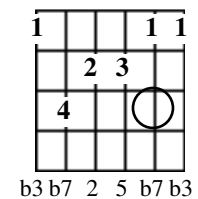

C m9 nr XI

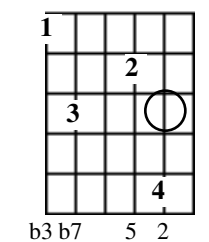

C m9 nr XII

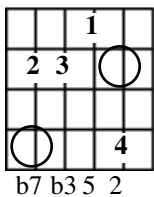

C m9 nr XII

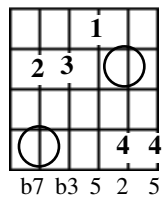

# minor ninth add six

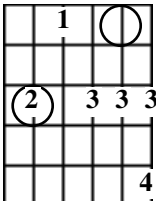
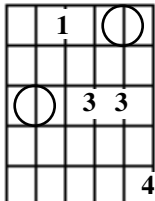
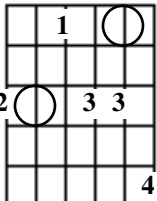
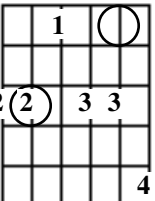
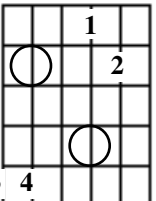
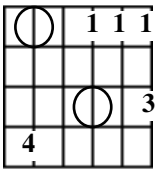
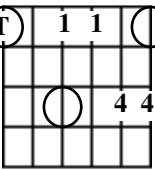
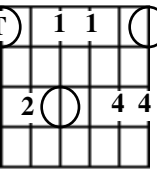
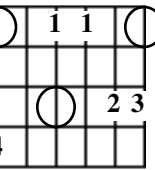
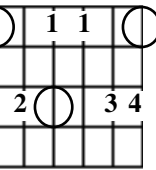
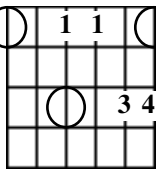
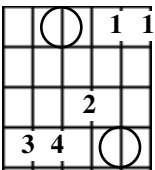
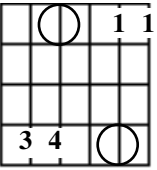
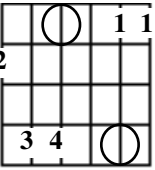
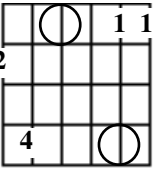
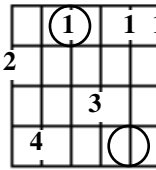
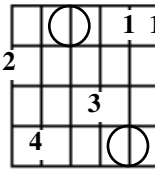
<p>C m9/6 I</p>  <p>1 b3 b7 2 6</p>	<p>C m9/6 nr I</p>  <p>b3 b7 2 6</p>	<p>C m9/6 nr I</p>  <p>5 b3 b7 2 6</p>	<p>C m9/6 I</p>  <p>5 1 b3 b7 2 6</p>	<p>C m9/6 nr II</p>  <p>b7 b3 6 2</p>
<p>C m9/6 nr III</p>  <p>b3 b7 2 6</p>	<p>C m9/6 VIII</p>  <p>1 b7 b3 6 2</p>	<p>C m9/6 VIII</p>  <p>1 5 b7 b3 6 2</p>	<p>C m9/6 VIII</p>  <p>b3 b7 b3 6 2</p>	<p>C m9/6 nr VIII</p>  <p>5 b7 b3 6 2</p>
<p>C m9/6 nr VIII</p>  <p>b7 b3 6 2</p>	<p>C m9/6 nr X</p>  <p>b7 b3 5 6 2</p>	<p>C m9/6 nr X</p>  <p>b7 b3 6 2</p>	<p>C m9/6 nr X</p>  <p>b3 b7 b3 6 2</p>	<p>C m9/6 nr X</p>  <p>b3 b7 6 2</p>
<p>C m9/6 X</p>  <p>b3 b7 1 5 6 2</p>	<p>C m9/6 nr X</p>  <p>b3 b7 5 6 2</p>			

# minor eleventh

C m11 I

1 b3 b7 2 4

C m11 I

1 b3 b7 1 4

C m11 I

1 b3 b7b3 4

C m11 I

b3 b7 1 4

C m11 nr I

5 b3 b7 4

C m11 nr I

5 b3 1 b3 4

C m11 I

5 b7 b3 b7 1 4

C m11 I

1 b3 b7 2 4

C m11 nr I

5 b3 b7 2 4

C m11 I

5 b3 b7 1 4

C m11 I

b7 b3 1 4

C m11 I

b7 b3 1 4

C m11 nr I

b7 b3 5 b7 4

C m11 nr I

b3 b7 2 4

C m11 III

1 4 b7 b3 5

C m11 III

1 4 b7 b3 b7

C m11 nr III

4 b7 b3 5

C m11 nr III

4 b7 b3

C m11 nr III

b3 b7 4 5

C m11 nr III

5 b3 4b7

C m11 III

1 4 1 b3 b7

C m11 nr III

b7 4 2 b3

C m11 nr III

b3 5 b7 2 4

C m11 nr III

5 b3 5 b7 4 5

C m11 nr III

b3 5 b7 4 5



C m11 nr VI

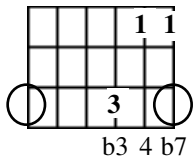

C m11 VI

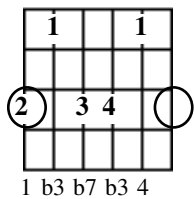

C m11 VI

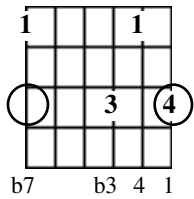

C m11 VI

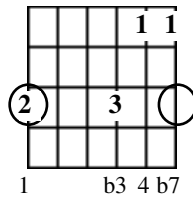

C m11 VI

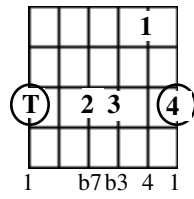

C m11 nr VI

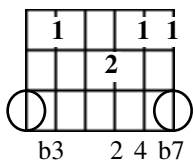

C m11 nr VI

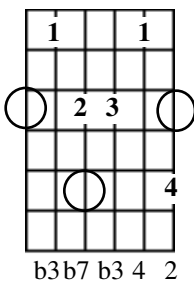

C m11 nr VI

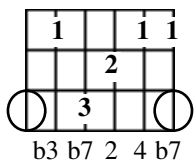

C m11 nr VI

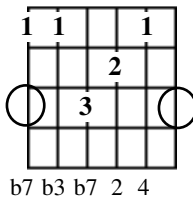

C m11 nr VI

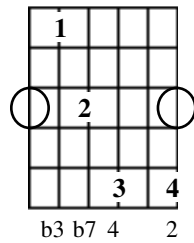

C m11 nr VI

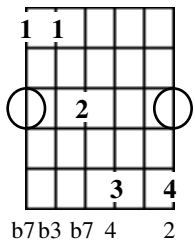

C m11 nr VI

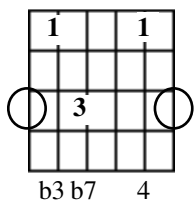

C m11 VI

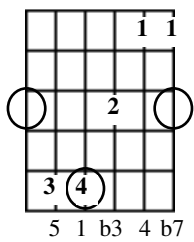

C m11 VI

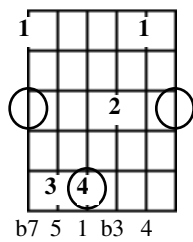

C m11 VI

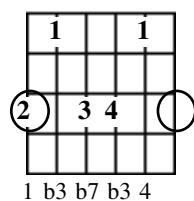

C m11 VI

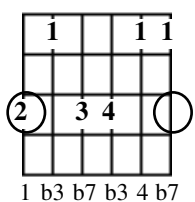

C m11 VI

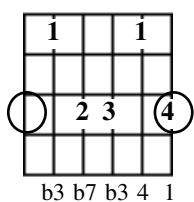

C m11 VI

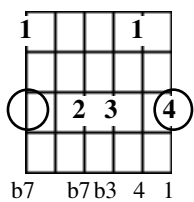

C m11 VI

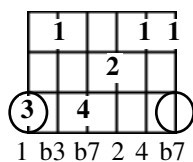

C m11 VI

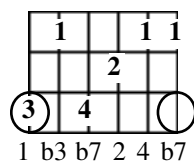

C m11 VI

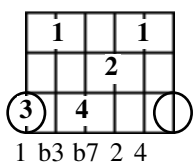

C m11 nr VI

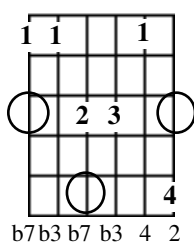

C m11 nr VI

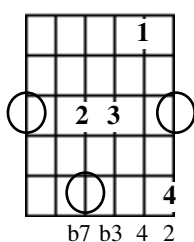

C m11 VII

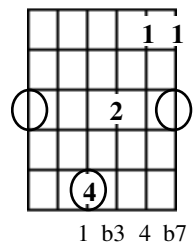

C m11 VII

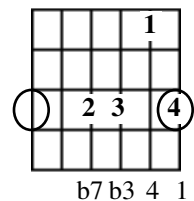



C m11 nr VII

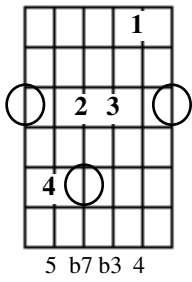

C m11 nr VII

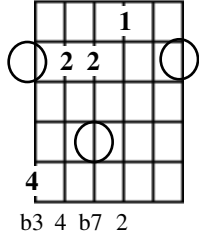

C m11 nr VIII

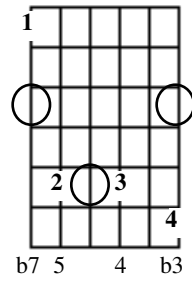

C m11 VIII

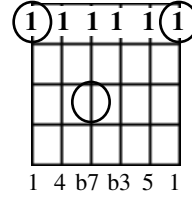

C m11 VIII

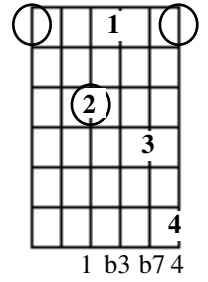

C m11 VIII

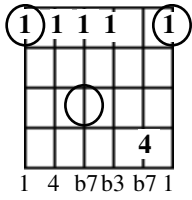

C m11 nr VIII

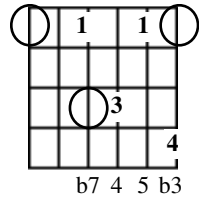

C m11 nr VIII

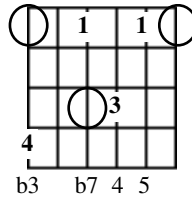

C m11 VIII

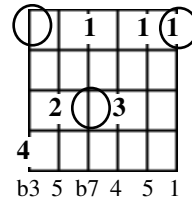

C m11 VIII

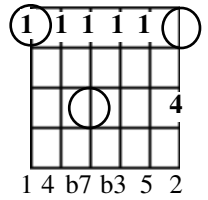

C m11 VIII

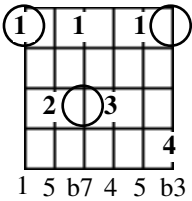

C m11 nr VIII

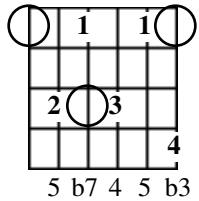

C m11 nr VIII

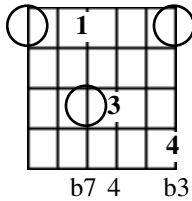

C m11 VIII

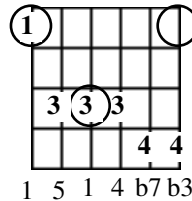

C m11 VIII

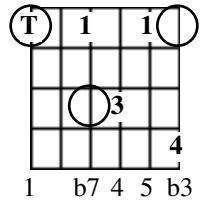

C m11 nr VIII

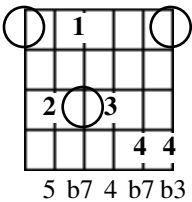

C m11 VIII

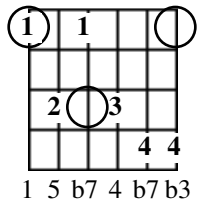

C m11 VIII

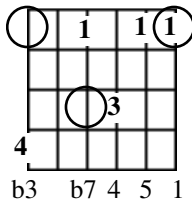

C m11 nr VIII

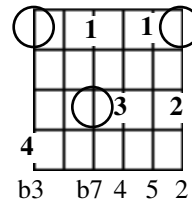

C m11 nr VIII

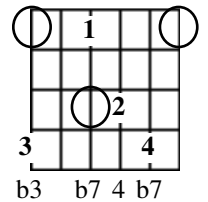

C m11 VIII

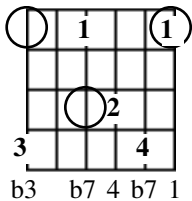

C m11 VIII

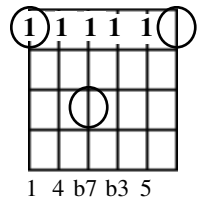

C m11 VIII

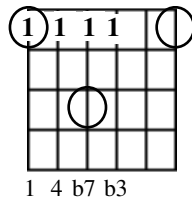

C m11 nr VIII

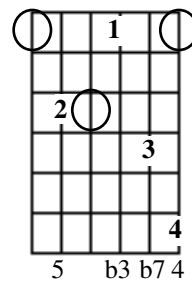

C m11 VIII

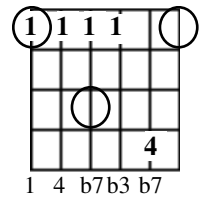

C m11 VIII

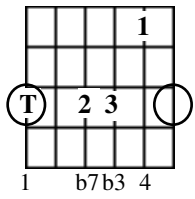

C m11 nr IX

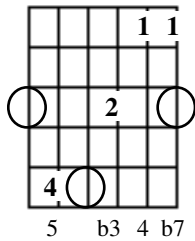

C m11 IX

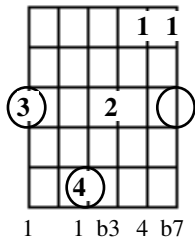

C m11 X

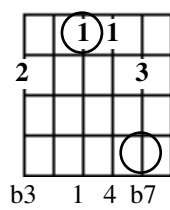

C m11 nr X

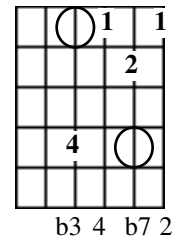

C m11 X

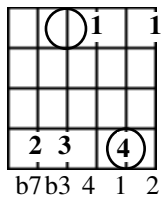

C m11 nr X

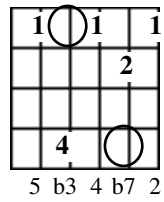

C m11 nr X

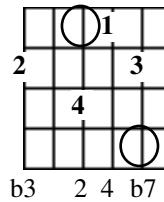

C m11 nr X

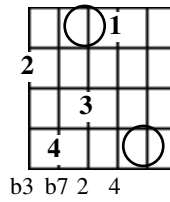

C m11 nr X

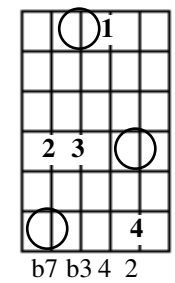

C m11 X

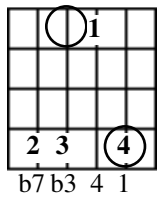

C m11 X

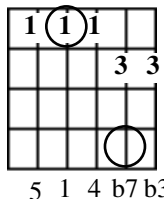

C m11 X

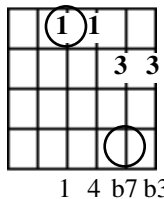

C m11 X

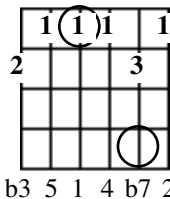

C m11 X

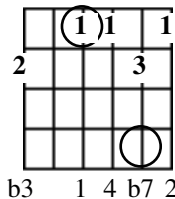

C m11 X

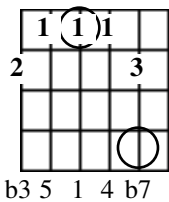

C m11 nr X

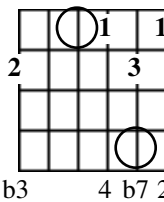

C m11 X

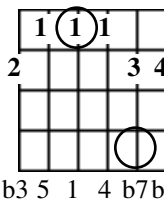

C m11 nr X

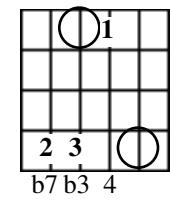

C m11 nr X

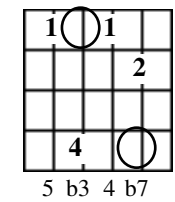

C m11 nr X

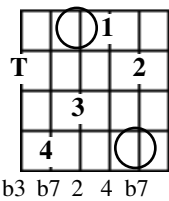

C m11 nr XI

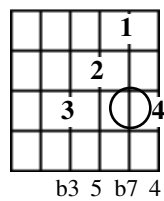

C m11 nr XI

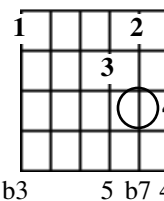

C m11 nr XI

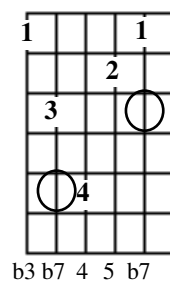

C m11 nr XI

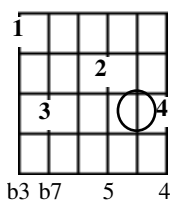

C m11 nr XI

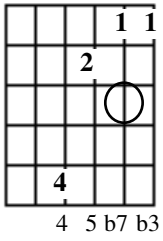

C m11 XI

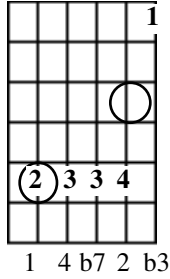

C m11 nr XI

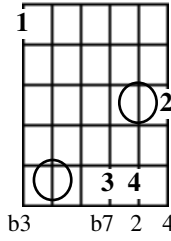

C m11 nr XI

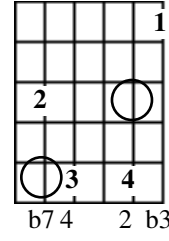

C m11 nr XI

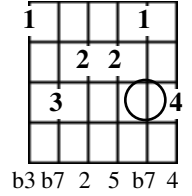

C m11 nr XI

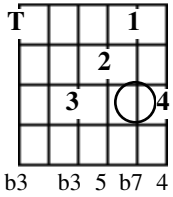

C m11 nr XI

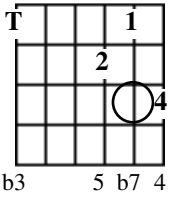

C m11 nr XI

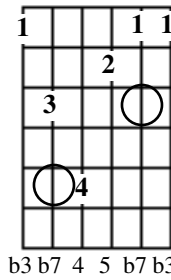

C m11 XI

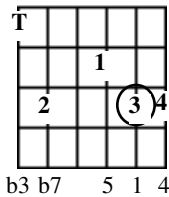

C m11 XII

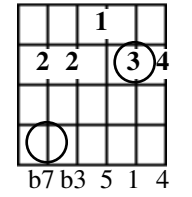

C m11 nr XII

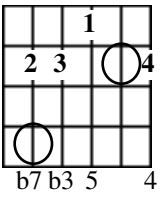

C m11 XII

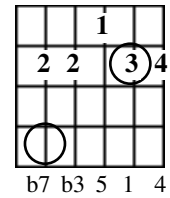

C m11 nr XII

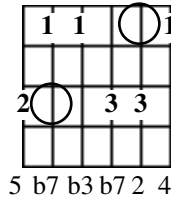

C m11 XII

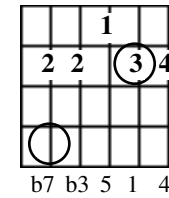

C m11 nr XII

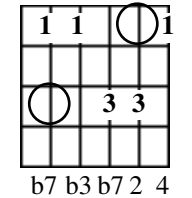

# minor thirteenth

C m13 I  1 b3 b7 2 6	C m13 nr I  b3 b7 6	C m13 I  b3 b7 1 6	C m13 nr I  b3 b7 2 6	C m13 I  1 b3 b7 6
C m13 I  1 b3 b7 1 6	C m13 nr I  5 b3 b7 6	C m13 I  5 b3 b7 1 6	C m13 nr I  5 b3 b7 2 6	C m13 I  5 1 b3 b7 2 6
C m13 nr II  b3 b7 b3 6	C m13 nr II  b7 b3 6	C m13 nr II  b7 b3 5 6	C m13 nr II  b7 b3 6 2	C m13 nr III  b3 b7 2 6
C m13 nr III  b7 b3 6	C m13 III  1 b7 b3 6	C m13 nr III  5 b7 b3 6	C m13 III  5 1 b7 b3 6	C m13 nr III  5 b7 b3 6
C m13 III  1 5 b7 b3 6	C m13 III  5 1 5 b7 b3 6	C m13 nr III  5 5 b7 b3 6	C m13 nr V  b7 b3 6	C m13 nr V  b7 b3 5 6



C m13 nr X

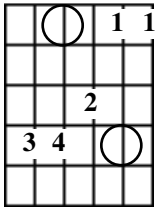

b7 b3 5 6 2

C m13 nr X

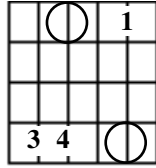

b7b3 6

C m13 nr X

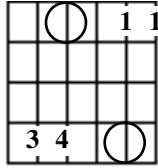

b7b3 6 2

C m13 nr X

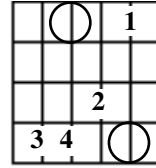

b7b3 5 6

C m13 nr X

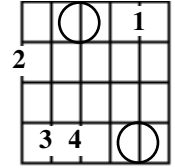

b3 b7b3 6

C m13 nr X

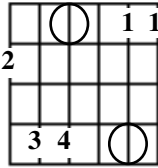

b3 b7b3 6 2

C m13 nr X

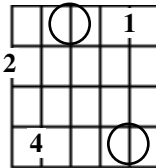

C m13 nr X

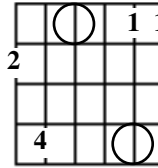

b3 b7 6 2

C m13 X

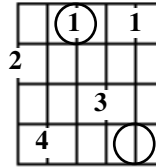

b3 b7 1 5 6

C m13 X

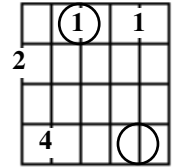

b3 b7 1 6

C m13 X

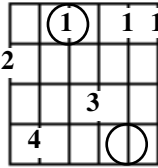

b3 b7 1 5 6 2

C m13 nr X

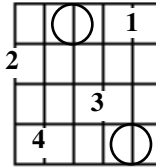

b3 b7 5 6

C m13 nr X

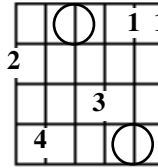

b3 b7 5 6 2

# minor sixth

C m6 I	C m6 I	C m6 I	C m6 I	C m6 II
C m6 nr II	C m6 nr II	C m6 nr II	C m6 nr II	C m6 nr III
C m6 nr III	C m6 nr III	C m6 III	C m6 IV	C m6 IV
C m6 nr IV	C m6 V	C m6 nr V	C m6 nr VI	C m6 VII
C m6 VII	C m6 VII	C m6 VIII	C m6 IX	C m6 IX

C m6 X

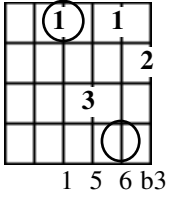

C m6 X

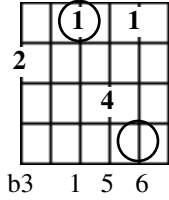

C m6 nr X

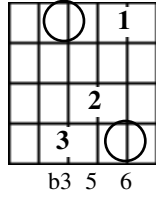

C m6 X

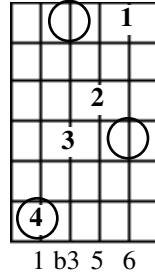

C m6 XI

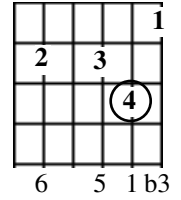

C m6 XI

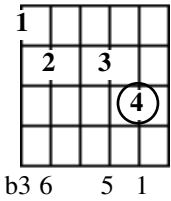

C m6 XI

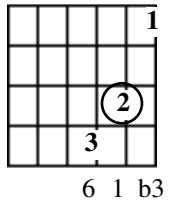

C m6 nr XII

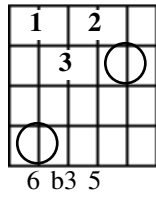

C m6 XII

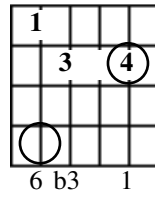

C m6 XII

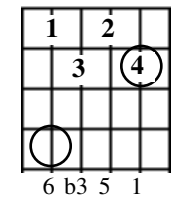



# minor sixth add nine

C m6/9 VI

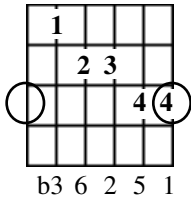

C m6/9 VI

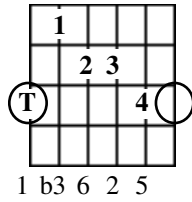

C m6/9 nr VI

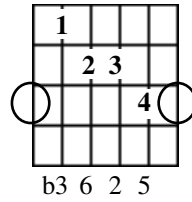

C m6/9 nr VI

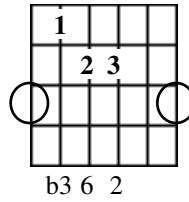

C m6/9 VI

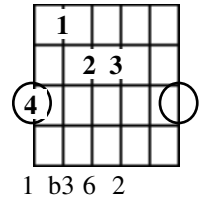

C m6/9 nr VII

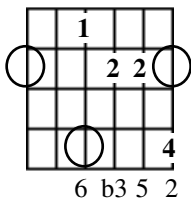

C m6/9 VII

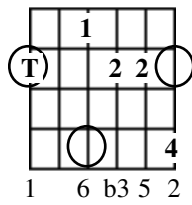

C m6/9 VII

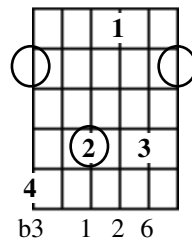

C m6/9 VIII

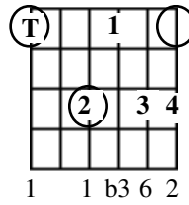

C m6/9 VIII

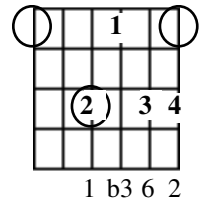

C m6/9 nr VIII

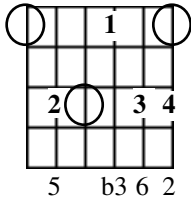

C m6/9 VIII

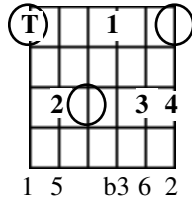

# minor (major seventh)

C m(ma7) I

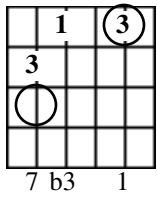

C m(ma7) II

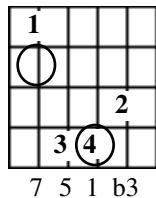

C m(ma7) nr II

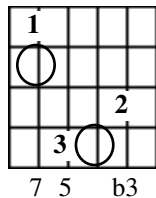

C m(ma7) III

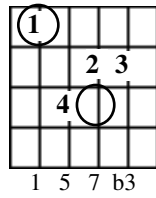

C m(ma7) nr III

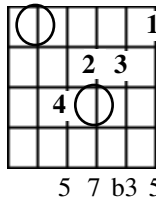

C m(ma7) nr III

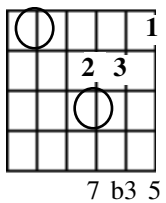

C m(ma7) nr III

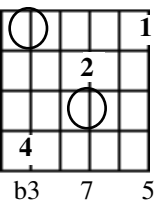

C m(ma7) nr IV

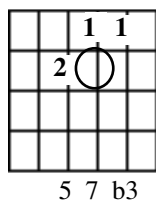

C m(ma7) nr IV

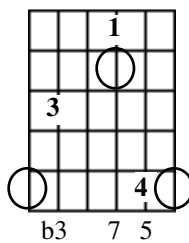

C m(ma7) nr IV

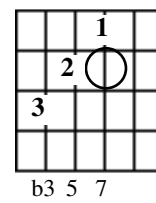

C m(ma7) nr IV

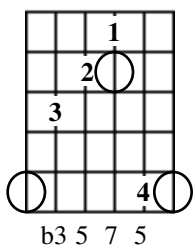

C m(ma7) nr V

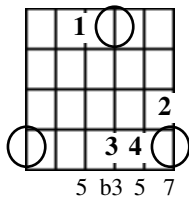

C m(ma7) nr V

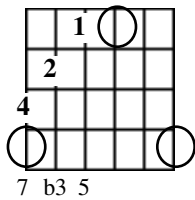

C m(ma7) nr V

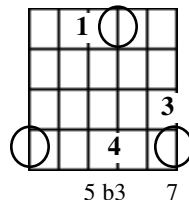

C m(ma7) VIII

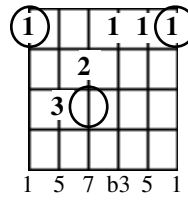

C m(ma7) VIII

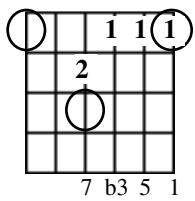

C m(ma7) VIII

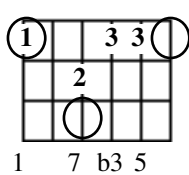

C m(ma7) IX

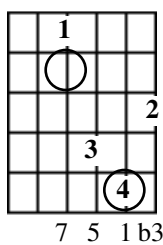

C m(ma7) IX

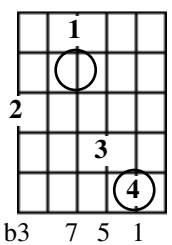

C m(ma7) X

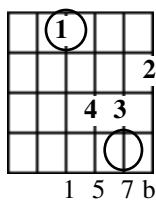

C m(ma7) X

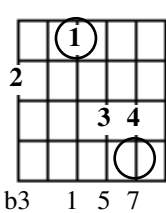

C m(ma7) nr XII

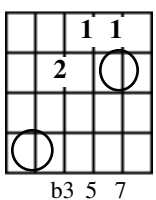

C m(ma7) nr XII

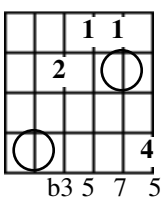

C m(ma7) XII

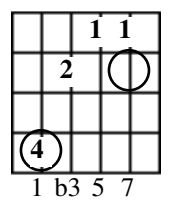

C m(ma7) nr XII

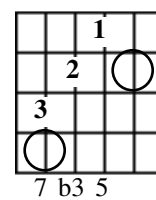

# minor (major seventh) add six

C m(ma7)/6 I

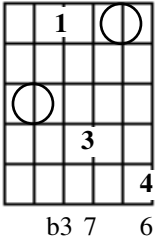

C m(ma7)/6 I

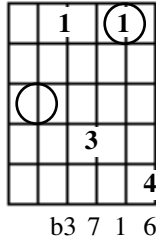

C m(ma7)/6 I

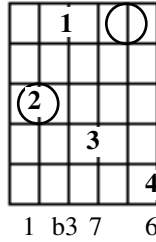

C m(ma7)/6 I

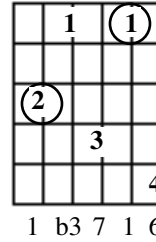

C m(ma7)/6 I

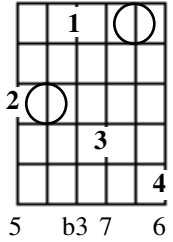

C m(ma7)/6 I

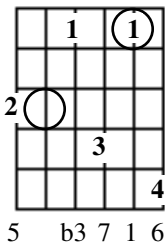

C m(ma7)/6 I

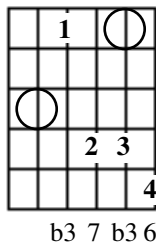

C m(ma7)/6 III

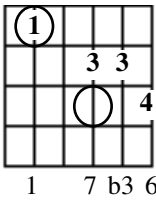

C m(ma7)/6 III

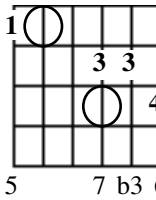

C m(ma7)/6 III

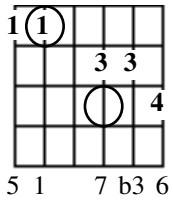

C m(ma7)/6 III

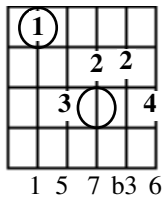

C m(ma7)/6 III

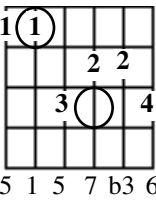

C m(ma7)/6 III

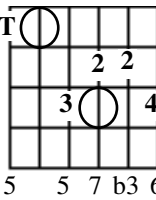

C m(ma7)/6 IV

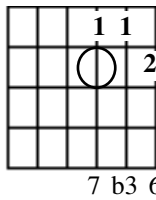

C m(ma7)/6 IV

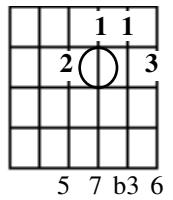

C m(ma7)/6 V

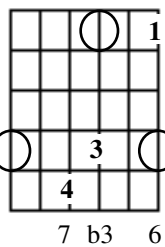

C m(ma7)/6 V

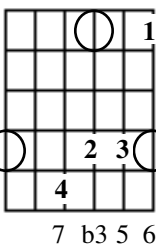

C m(ma7)/6 V

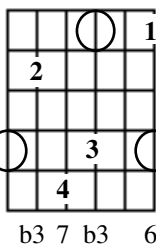

C m(ma7)/6 V

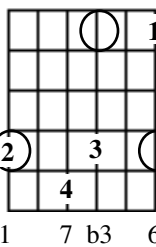

C m(ma7)/6 VIII

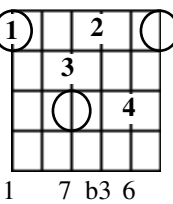

C m(ma7)/6 VIII

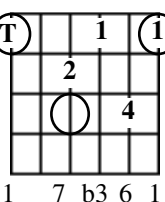

C m(ma7)/6 VIII

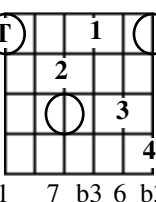

C m(ma7)/6 VIII

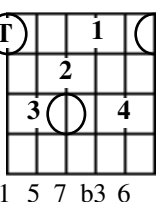

C m(ma7)/6 VIII

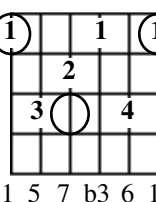

C m(ma7)/6 VIII

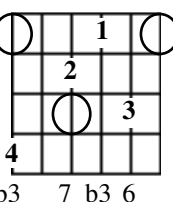

C m(ma7)/6 VIII

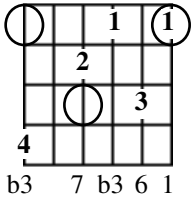

C m(ma7)/6 VIII

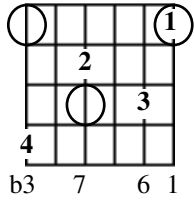

C m(ma7)/6 VIII

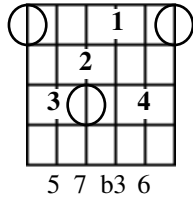

C m(ma7)/6 VIII

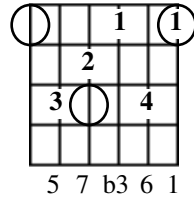

C m(ma7)/6 VIII

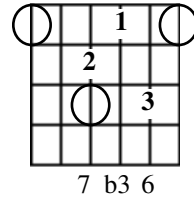

C m(ma7)/6 VIII

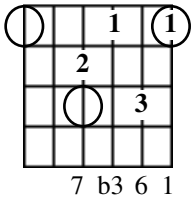

C m(ma7)/6 VIII

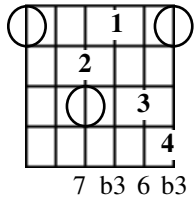

C m(ma7)/6 IX

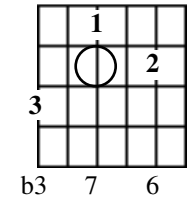

C m(ma7)/6 X

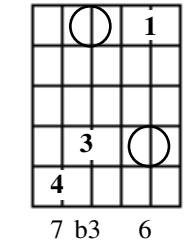

C m(ma7)/6 X

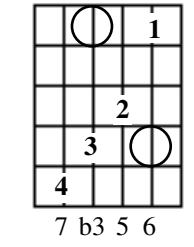

C m(ma7)/6 X

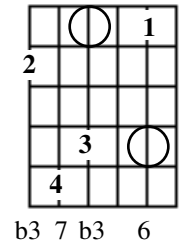

C m(ma7)/6 X

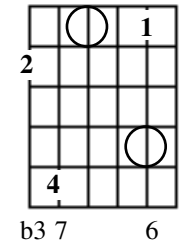

C m(ma7)/6 X

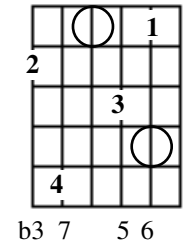

C m(ma7)/6 X

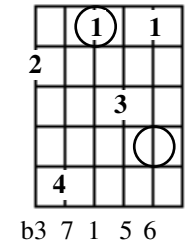

C m(ma7)/6 X

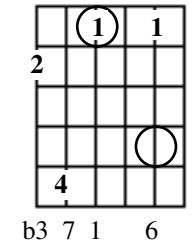

# minor ninth (major seventh)

C m9(ma7) I

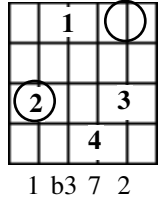

C m9(ma7) I

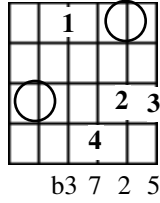

C m9(ma7) I

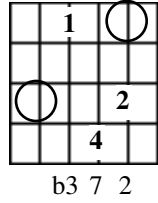

C m9(ma7) I

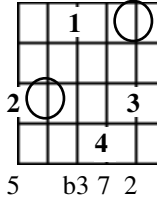

C m9(ma7) III

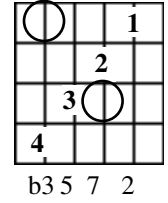

C m9(ma7) III

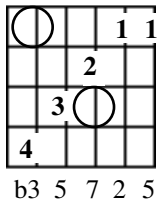

C m9(ma7) III

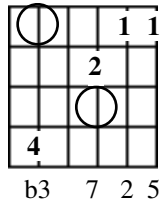

C m9(ma7) III

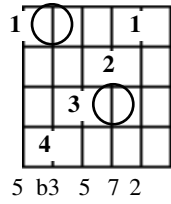

C m9(ma7) VI

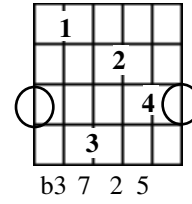

C m9(ma7) VI

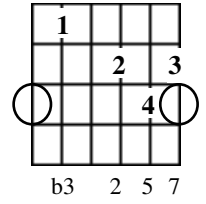

C m9(ma7) VI

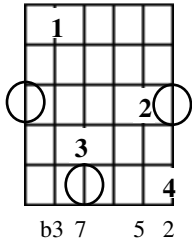

C m9(ma7) VII

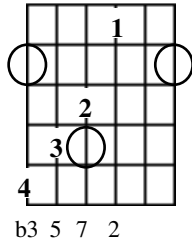

C m9(ma7) VIII

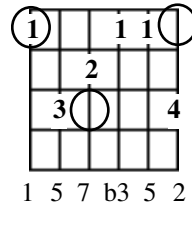

C m9(ma7) VIII

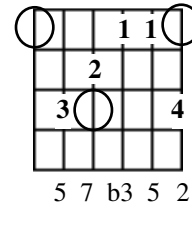

C m9(ma7) VIII

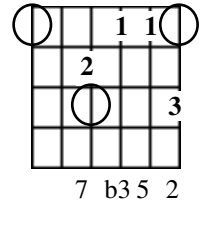

C m9(ma7) VIII

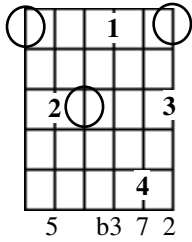

C m9(ma7) VIII

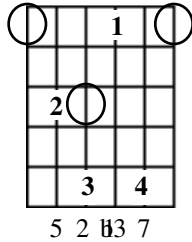

C m9(ma7) VIII

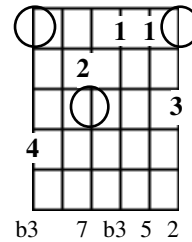

C m9(ma7) X

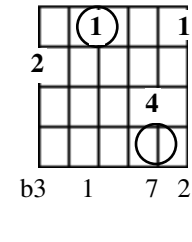

C m9(ma7) X

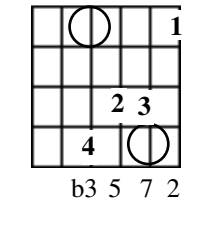

C m9(ma7) X

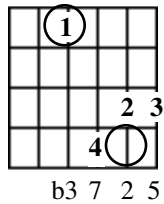

C m9(ma7) X

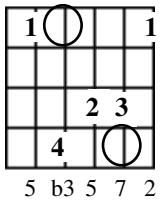

C m9(ma7) X

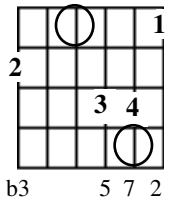

C m9(ma7) X

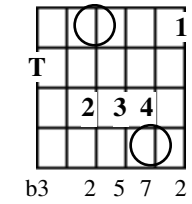

C m9(ma7) XI

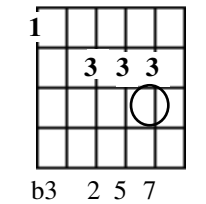

C m9(ma7) XI

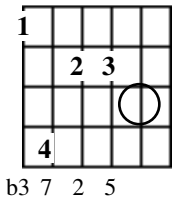

C m9(ma7) XI

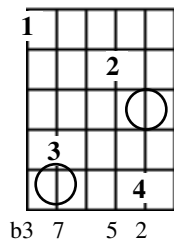

## minor ninth (major seventh) add six

C m9(ma7)/6 I

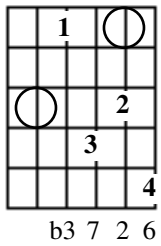

C m9(ma7)/6 VIII

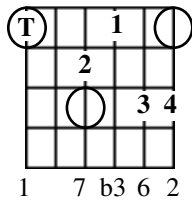

C m9(ma7)/6 VIII

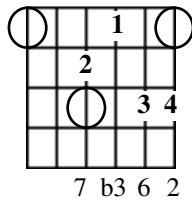

C m9(ma7)/6 VIII

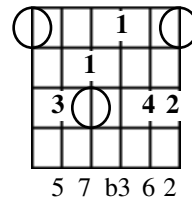

C m9(ma7)/6 IX

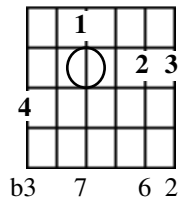

C m9(ma7)/6 X

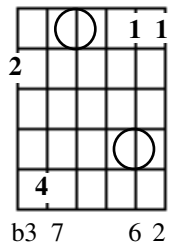

C m9(ma7)/6 X

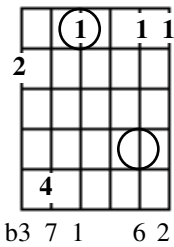

C m9(ma7)/6 X

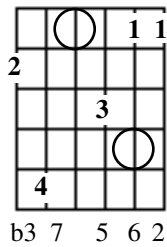

C m9(ma7)/6 X

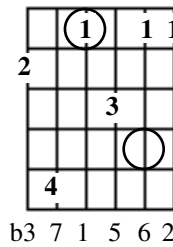

C m9(ma7)/6 X

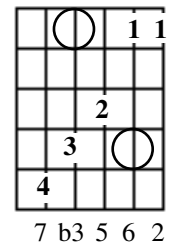

C m9(ma7)/6 X

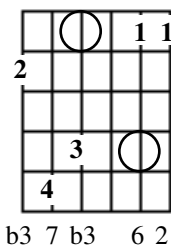

# minor seventh flat five

C m7b5 I

b3 b7 1 b5

C m7b5 I

b5 b3 b7 1

C m7b5 I

b5 1 b3 b7

C m7b5 II

1 b7 b3 b5

C m7b5 III

1 b5 b7 b3

C m7b5 III

1 b5 b3 b7

C m7b5 IV

b5 1 b3 b7

C m7b5 IV

b7 b5 1 b3

C m7b5 V

b3 b7 1 b5

C m7b5 V

b3 1 b5 b7

C m7b5 VI

1 b3 b5 b7

C m7b5 VI

1 b3 b5 b7

C m7b5 VII

1 b7 b3 b5

C m7b5 VII

b7 b3 b5 1

C m7b5 VIII

b5 1 b3 b7

C m7b5 VIII

1 b5 1 b3 b7 1

C m7b5 VIII

b5 b3 b7 1

C m7b5 VIII

1 b5 b7 b3

C m7b5 VIII

b5 1 b3 b7 1

C m7b5 VIII

1 b5 1 b3 b7

C m7b5 VIII

1 b5 1 b5 b7 b3

C m7b5 IX

b5 1 b5 b7 b3

C m7b5 X

1 b5 b7 b3

C m7b5 X

b3 1 b5 b7

C m7b5 X

b3 1 b5 b7 b3

C m7b5 XI

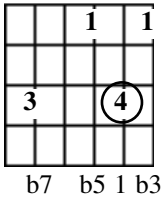

C m7b5 nr XI

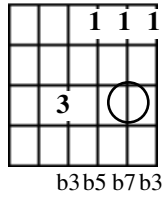

C m7b5 XI

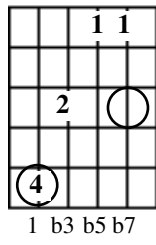

C m7b5 XI

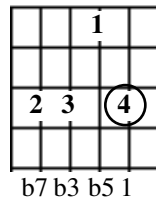

C m7b5 XI

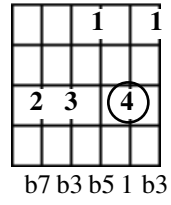



# minor seventh add eleven flat five

C m7/11b5 I

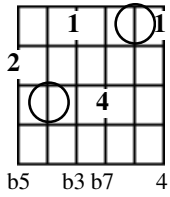

C m7/11b5 I

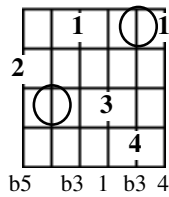

C m7/11b5 I

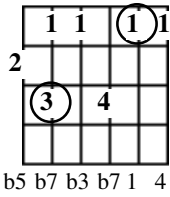

C m7/11b5 I

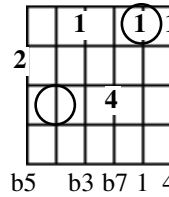

C m7/11b5 I

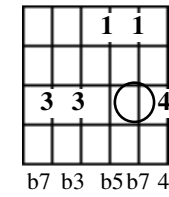

C m7/11b5 II

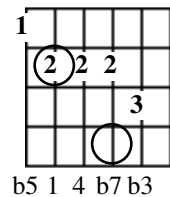

C m7/11b5 II

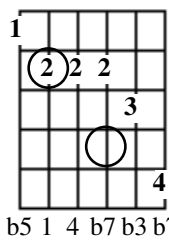

C m7/11b5 III

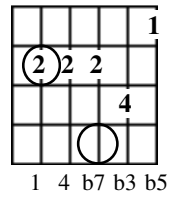

C m7/11b5 III

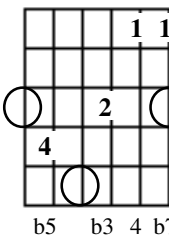

C m7/11b5 III

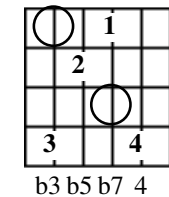

C m7/11b5 III

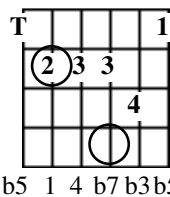

C m7/11b5 IV

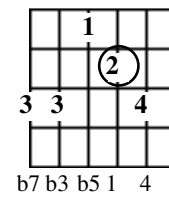

C m7/11b5 IV

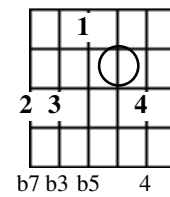

C m7/11b5 IV

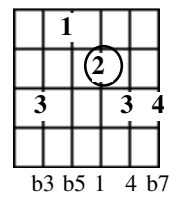

C m7/11b5 V

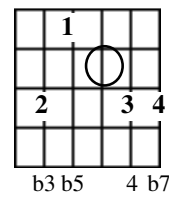

C m7/11b5 VI

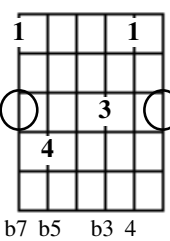

C m7/11b5 VI

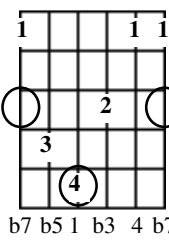

C m7/11b5 VI

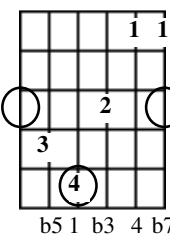

C m7/11b5 VI

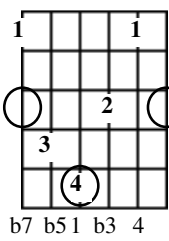

C m7/11b5 VII

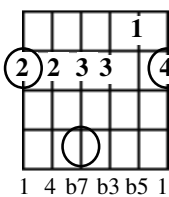

C m7/11b5 VII

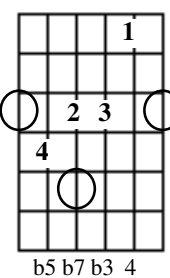

C m7/11b5 VII

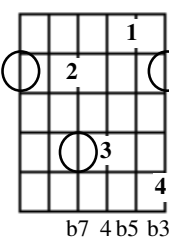

C m7/11b5 VII

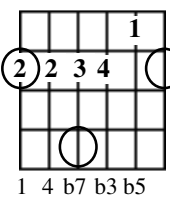

C m7/11b5 VIII

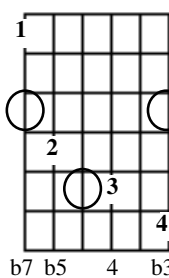

C m7/11b5 VIII

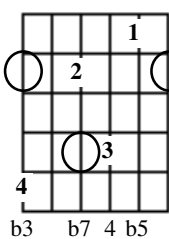

C m7/11b5 VIII

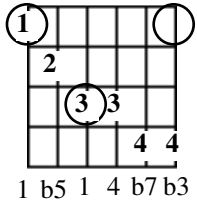

C m7/11b5 VIII

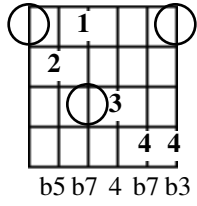

C m7/11b5 VIII

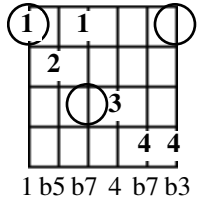

C m7/11b5 VIII

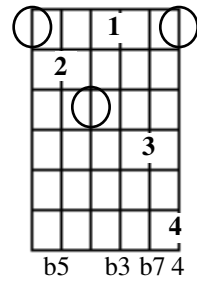

C m7/11b5 IX

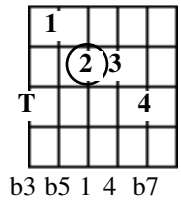

C m7/11b5 X

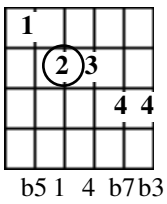

C m7/11b5 X

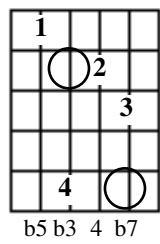

C m7/11b5 XI

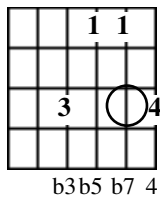

C m7/11b5 XI

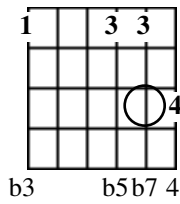

C m7/11b5 XI

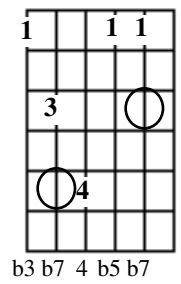

C m7/11b5 XI

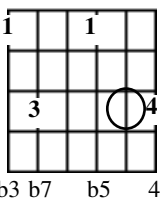

C m7/11b5 XI

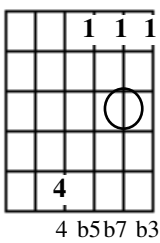

C m7/11b5 XI

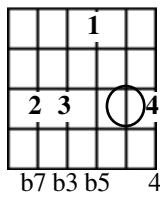

C m7/11b5 XI

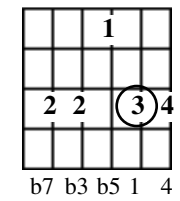

C m7/11b5 XI

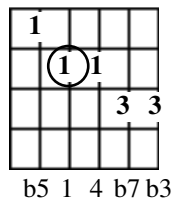

C m7/11b5 XI

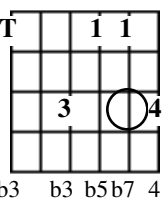

C m7/11b5 XI

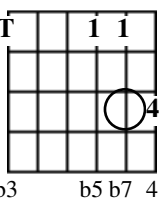

C m7/11b5 XI

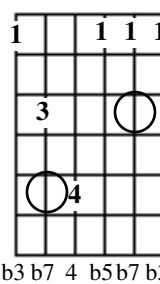

C m7/11b5 XI

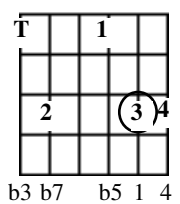

C m7/11b5 XI

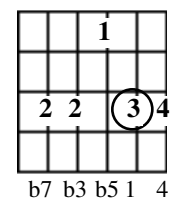

C m7/11b5 XII

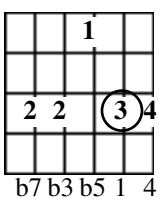

# minor ninth flat five

C m9b5 nr I

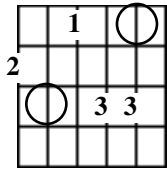

b5 b3 b7 2

C m9b5 nr I

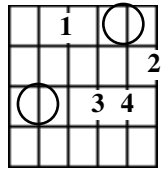

b3 b7 2 b5

C m9b5 nr I

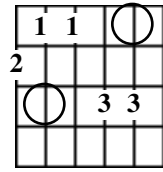

b5 b7 b3 b7 2

C m9b5 nr II

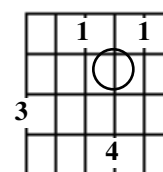

b7 b5 2 b3

C m9b5 nr III

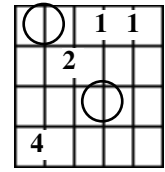

b3 b5 b7 2

C m9b5 nr III

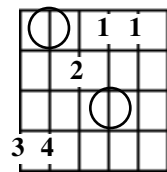

b7 b3 b5 b7 2

C m9b5 nr III

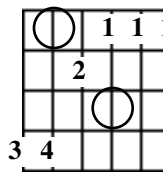

b7 b3 b5 b7 2 b3

C m9b5 nr III

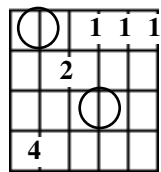

b3 b5 b7 2 5

C m9b5 nr III

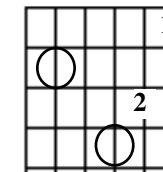

b7 2 b3 b5

C m9b5 nr IV

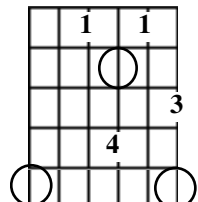

b5 2 b3 b7

C m9b5 nr V

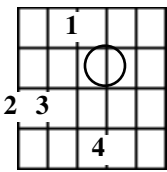

b7 b3 b5 2

C m9b5 nr VI

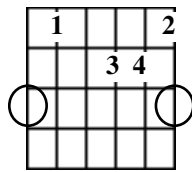

b3 2 b5 b7

C m9b5 nr VI

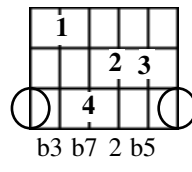

b3 b7 2 b5

C m9b5 nr VI

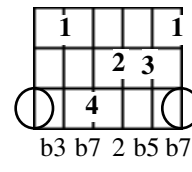

b3 b7 2 b5 b7

C m9b5 nr VI

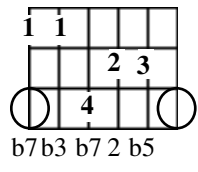

b7 b3 b7 2 b5

C m9b5 nr VI

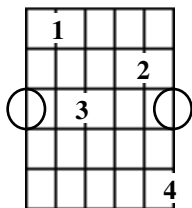

b3 b7 b5 2

C m9b5 nr VI

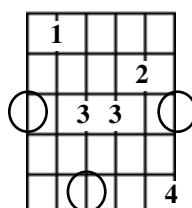

b3 b7 b3 b5 2

C m9b5 nr VII

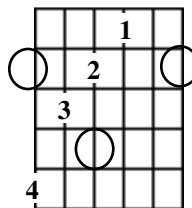

b3 b5 b7 2

C m9b5 VIII

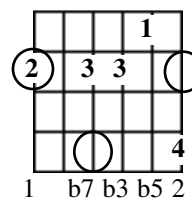

1 b7 b3 b5 2

C m9b5 VIII

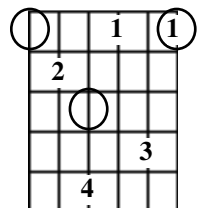

b5 2 b3 b7 1

C m9b5 nr VIII

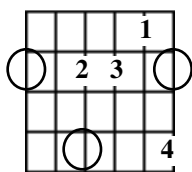

b7 b3 b5 2

C m9b5 nr X

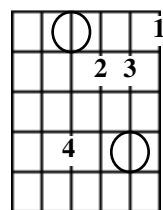

b3 b5 b7 2

C m9b5 X

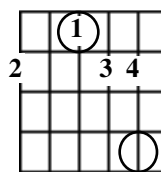

b3 1 b5 b7 2

C m9b5 X

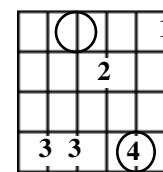

b7 b3 b5 1 2

C m9b5 nr X

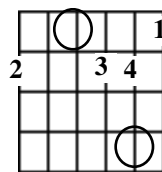

b3 b5 b7 2

C m9b5 nr XI

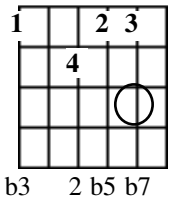

C m9b5 nr XI

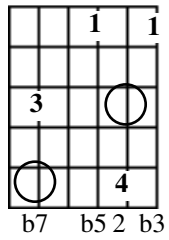

C m9b5 nr XI

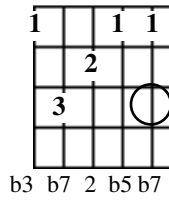

C m9b5 nr XI

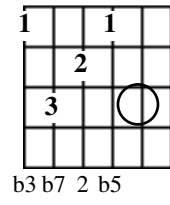

C m9b5 nr XI

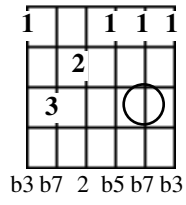

C m9b5 nr XI

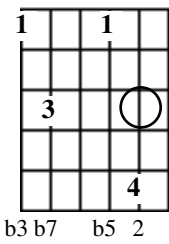

C m9b5 nr XI

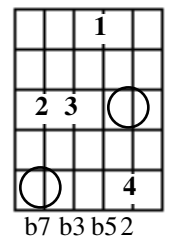

# minor eleventh flat five

C m11b5 nr I

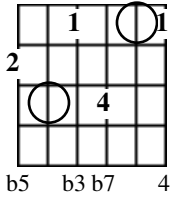

C m11b5 nr I

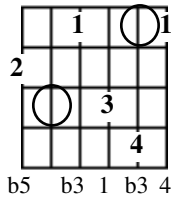

C m11b5 I

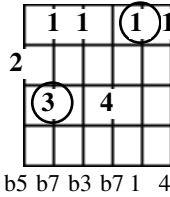

C m11b5 nr I

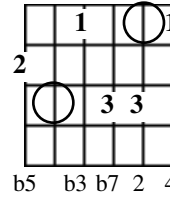

C m11b5 I

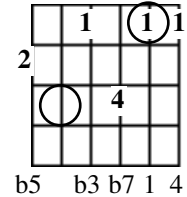

C m11b5 nr I

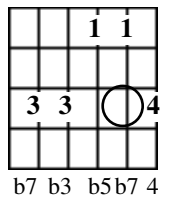

C m11b5 II

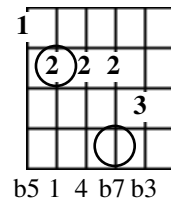

C m11b5 II

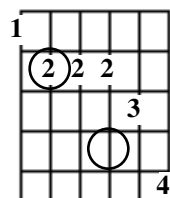

C m11b5 nr II

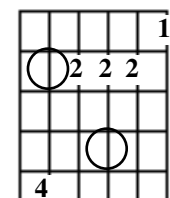

C m11b5 III

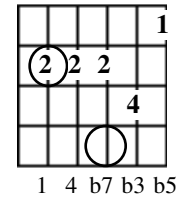

C m11b5 nr III

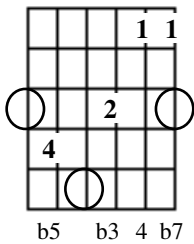

C m11b5 nr III

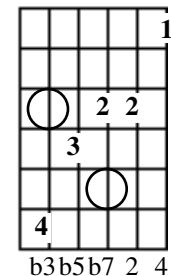

C m11b5 nr III

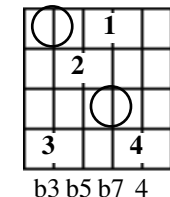

C m11b5 III

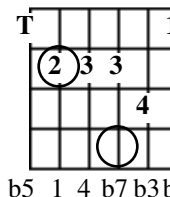

C m11b5 IV

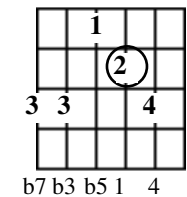

C m11b5 nr IV

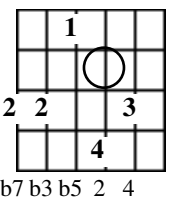

C m11b5 nr IV

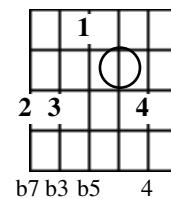

C m11b5 IV

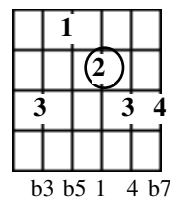

C m11b5 nr IV

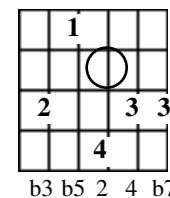

C m11b5 nr V

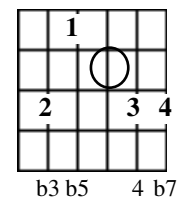

C m11b5 nr VI

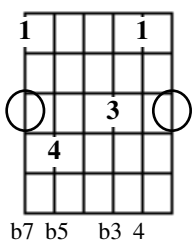

C m11b5 VI

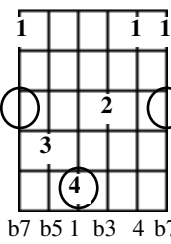

C m11b5 VI

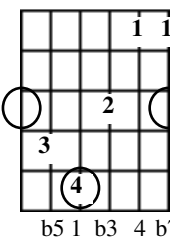

C m11b5 VI

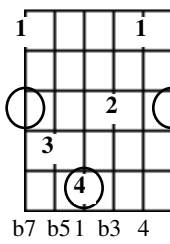

C m11b5 VII

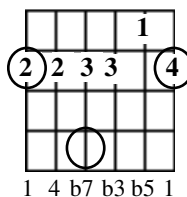

C m11b5 nr VII

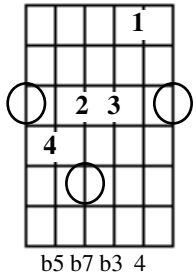

C m11b5 nr VII

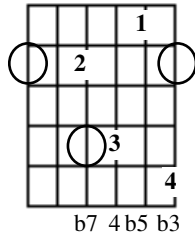

C m11b5 VII

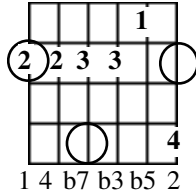

C m11b5 VII

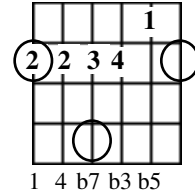

C m11b5 nr VIII

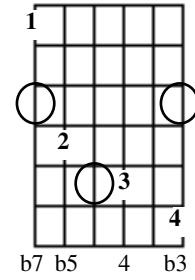

C m11b5 nr VIII

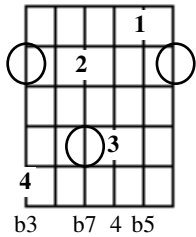

C m11b5 VIII

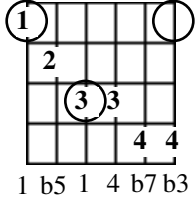

C m11b5 nr VIII

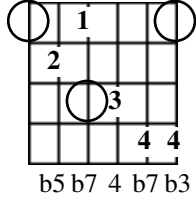

C m11b5 VIII

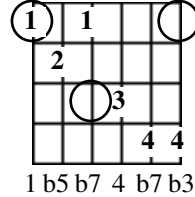

C m11b5 nr VIII

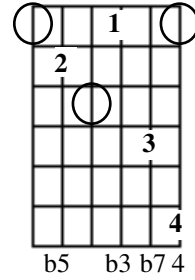

C m11b5 IX

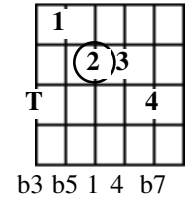

C m11b5 X

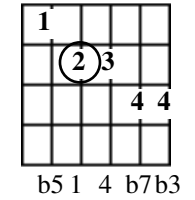

C m11b5 nr X

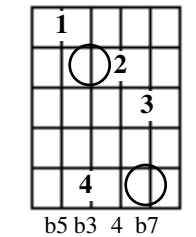

C m11b5 nr XI

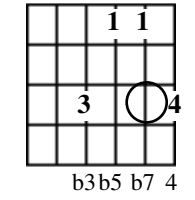

C m11b5 nr XI

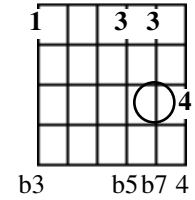

C m11b5 nr XI

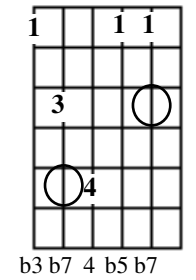

C m11b5 nr XI

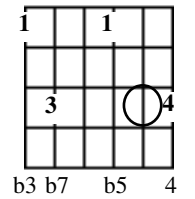

C m11b5 nr XI

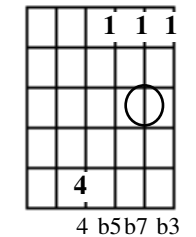

C m11b5 nr XI

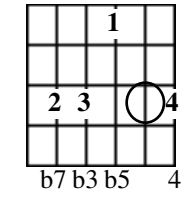

C m11b5 nr XI

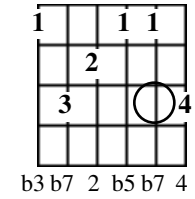

C m11b5 XI

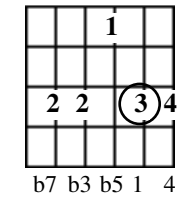

C m11b5 XI

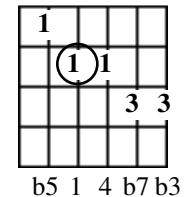

C m11b5 nr XI

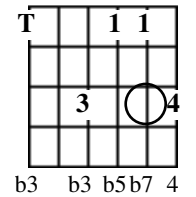

C m11b5 nr XI

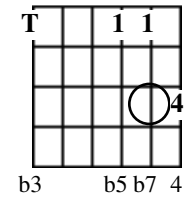

C m11b5 nr XI

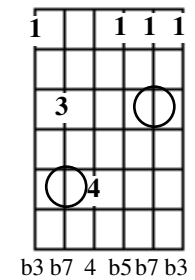

C m11b5 XI

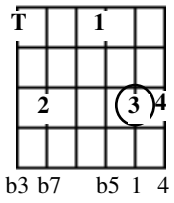

C m11b5 XI

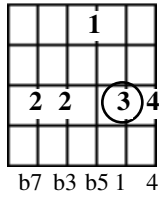

C m11b5 XII

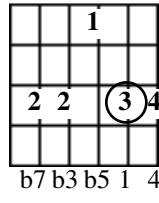

C m11b5 nr XII

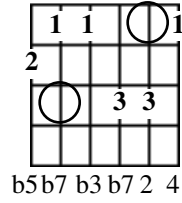

# minor (major seventh) flat five

C m(ma7)b5 II

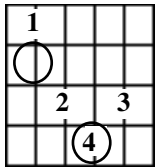

7 b5 1 b3

C m(ma7)b5 II

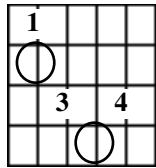

7 b5 b3

C m(ma7)b5 II

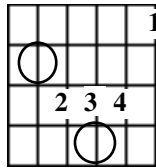

b5 7 b3 b5

C m(ma7)b5 II

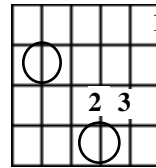

7 b3 b5

C m(ma7)b5 II

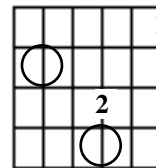

b3 7 b5

C m(ma7)b5 IV

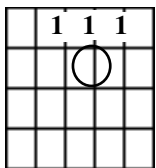

b5 7 b3

C m(ma7)b5 IV

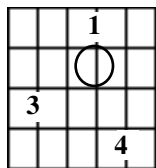

b3 7 b5

C m(ma7)b5 IV

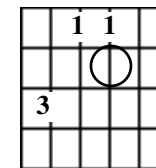

b3 b5 7

C m(ma7)b5 IV

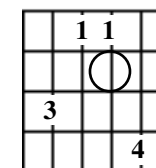

b3 b5 7 b5

C m(ma7)b5 IV

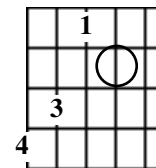

7 b3 b5

C m(ma7)b5 V

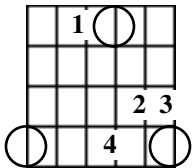

5 b3 b5 7

C m(ma7)b5 VII

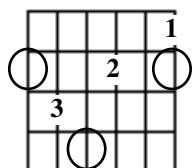

b5 b3 7

C m(ma7)b5 VII

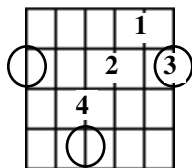

7 b3 b5 1

C m(ma7)b5 VII

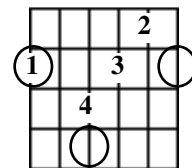

1 7 b3 b5

C m(ma7)b5 VII

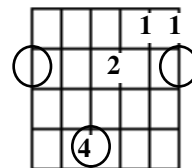

1 b3 b5 7

C m(ma7)b5 VII

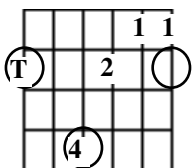

1 1 b3 b5 7

C m(ma7)b5 IX

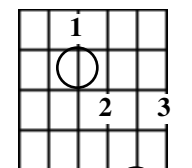

7 b5 1 b3

C m(ma7)b5 IX

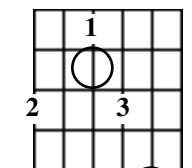

b3 7 b5 1

C m(ma7)b5 X

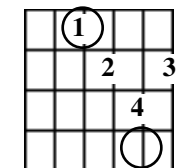

1 b5 7 b3

C m(ma7)b5 X

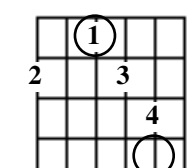

b3 1 b5 7

C m(ma7)b5 XI

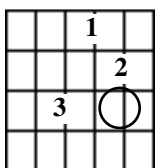

b3 b5 7

C m(ma7)b5 XI

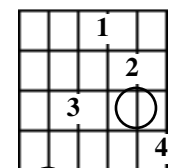

b3 b5 7 b5

C m(ma7)b5 XI

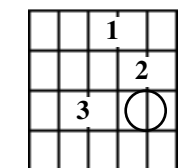

1 b3 b5 7



# minor ninth (major seventh) flat five

C m9(ma7)b5 II

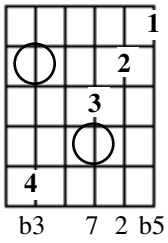

C m9(ma7)b5 III

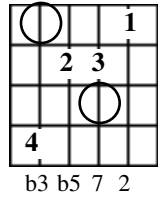

C m9(ma7)b5 VII

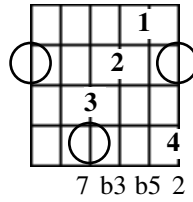

C m9(ma7)b5 IX

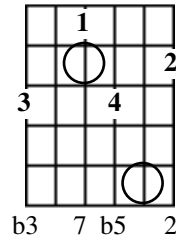

C m9(ma7)b5 X

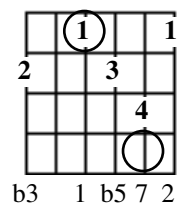

C m9(ma7)b5 X

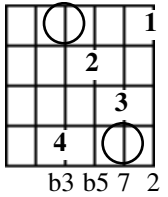

C m9(ma7)b5 XI

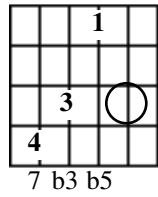

# diminished seventh

C dim7 I

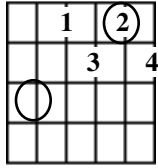

b3 6 1 b5

C dim7 I

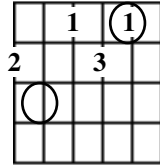

b5 b3 6 1

C dim7 II

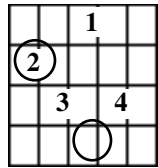

1 b5 6 b3

C dim7 III

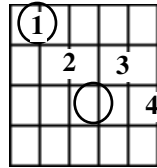

1 b5 b3 6

C dim7 IV

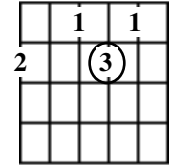

6 b5 1 b3

C dim7 IV

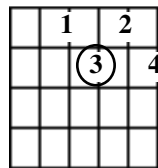

b5 1 b3 6

C dim7 V

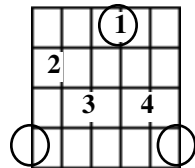

b3 6 1 b5

C dim7 V

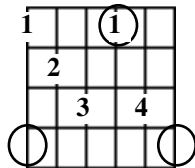

6 b3 6 1 b5

C dim7 V

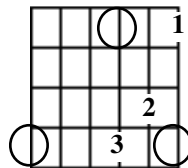

1 b3 b5 6

C dim7 VI

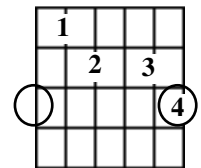

b3 6 b5 1

C dim7 VII

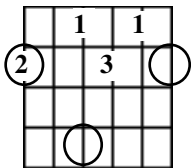

1 6 b3 b5

C dim7 VII

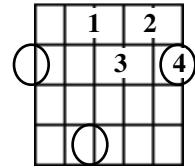

6 b3 b5 1

C dim7 VIII

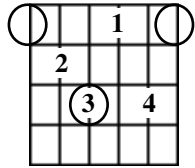

b5 1 b3 6

C dim7 VIII

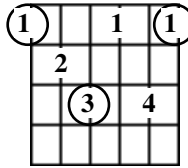

1 b5 1 b3 6 1

C dim7 IX

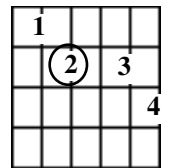

b5 1 6 b3

C dim7 X

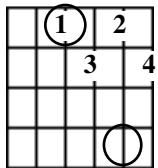

1 b5 6 b3

C dim7 X

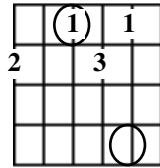

b3 1 b5 6

C dim7 XI

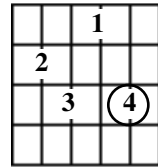

6 b3 b5 1

C dim7 XII

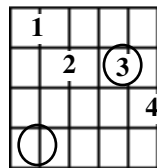

6 b3 1 b5

# diminished seventh add nine

C dim7/9 VII

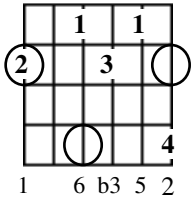

C dim7/9 VIII

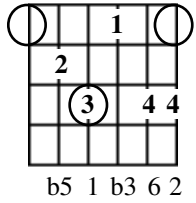

C dim7/9 X

